

# BKW65N75LZ1

## 650V 75A Trench FS IGBT

### Description

The BKW65N75LZ1 is a Trench FS IGBT utilizing bestirpower's advanced technology, which achieves an exceptionally low gate charge. It achieves significantly higher efficiency through optimized gate charge management, while its user-friendly design offers designers advantages such as low EMI and reduced switching losses.

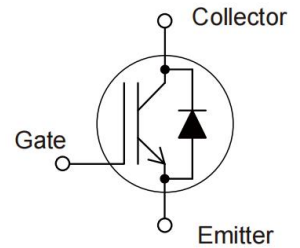
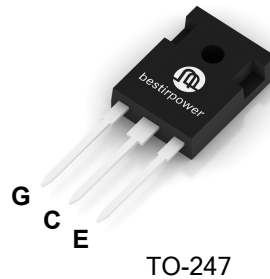
$V_{CE}$	$I_C (T_C = 100^\circ\text{C})$	$V_{CEsat}$	$Q_{g,typ}$
650 V	75 A	1.6 V	333 nC

### Applications

- Industrial UPS
- Welding Machine
- Solar Converters
- Energy Storage
- EV Charger

### Features

- Low Switching Power Loss
- Low Switching Surge and Noise
- Advanced Field Stop Technology
- Low EMI
- Maximum Junction Temperature 175°C
- Qualified According to JEDEC For Target Applications
- Pb-free Lead Plating, Halogen-free Mold Compound, RoHS Compliant



### Absolute Maximum Ratings

Symbol	Parameter	Value max	Unit	Note	
$V_{CE}$	Collector-emitter voltage ( $T_{vj} \geq 25^\circ\text{C}$ )	650	V		
$V_{GE}$	Gate-emitter voltage	$\pm 20$	V		
$I_C$	DC collector current, limited by $T_{vjmax}$	$T_C = 25^\circ\text{C}$	125	A	
		$T_C = 100^\circ\text{C}$	75	A	
$I_{Cpulse}$	Pulsed collector current, $t_p$ limited by $T_{vjmax}$	300	A		
$P_{tot}$	Power Dissipation	$P_{D\_IGBT}$	500	W	Fig.2
		$P_{D\_FWD}$	454		
$I_F$	Diode forward current, limited by $T_{vjmax}$	$T_C = 25^\circ\text{C}$	115	A	
		$T_C = 100^\circ\text{C}$	75		
$T_{sc}$	Short circuit withstand time, $V_{GE} = 15\text{V}$ , $V_{CE} \leq 400\text{V}$	5	$\mu\text{s}$		
$T_J$	Operating junction temperature	-40~ 175	$^\circ\text{C}$		
$T_{STG}$	Storage temperature range	-55~ 175	$^\circ\text{C}$		

### Thermal Resistance

Symbol	Parameter	Value	Unit
$R_{th(j-a)}$	Thermal resistance, junction-ambient	50	$^\circ\text{C/W}$
$R_{th(j-c)}$	Thermal resistance, IGBT junction to case	0.3	$^\circ\text{C/W}$
$R_{th(j-c)}$	Thermal resistance, diodes junction to case	0.33	$^\circ\text{C/W}$

**Electrical Characteristics** ( $T_J = 25^\circ\text{C}$  unless otherwise noted)

Symbol	Parameter	Test Conditions	Min	Typ	Max	Unit	Note	
<b>Statistic Characteristics</b>								
$V_{(BR)CES}$	Collector-emitter Breakdown Voltage	$V_{GE}=0V, I_c=0.5mA$	650	-	-	V		
$I_{CES}$	Collector Cut-off Current	$V_{CE}=650V, V_{GE}=0V$	-	-	200	$\mu A$		
$I_{GES}$	Gate-emitter Leakage Current	$V_{GE}=\pm 20V, V_{GE}=0V$	-	-	$\pm 200$	nA		
$V_{GE(TH)}$	Gate Threshold Voltage	$V_{CE}=V_{GE}, I_c=250\mu A$	5.0	5.8	6.6	V	Fig.5	
$V_{CE(sat)}$	Collector-Emitter Saturation Voltage	$V_{GE}=15V$ $I_c=75A$	$T_J=25^\circ\text{C}$	-	1.6	2.25	V	Fig.3 4
			$T_J=175^\circ\text{C}$	-	2.0	-		

**Dynamic Characteristics**

$C_{ies}$	Input Capacitance	$V_{CE}=25V,$ $V_{GE}=0V, f=1MHz$	-	8385	-	pF	Fig.11
$C_{oes}$	Output Capacitance		-	235	-		
$C_{res}$	Reverse Transfer Capacitance		-	62	-		

**Switching Parameters**

$t_{d(on)}$	Turn-on Delay Time	$V_{CE}=400V,$ $I_{DC}=75A,$ $R_G=10\Omega,$ $V_{GE}=0/+15V$	$T_J=25^\circ\text{C}$	-	79	-	ns
			$T_J=175^\circ\text{C}$	-	66	-	ns
$t_r$	Rise Time		$T_J=25^\circ\text{C}$	-	146	-	ns
			$T_J=175^\circ\text{C}$	-	141	-	ns
$t_{d(off)}$	Turn-off Delay Time		$T_J=25^\circ\text{C}$	-	215	-	ns
			$T_J=175^\circ\text{C}$	-	237	-	ns
$t_f$	Fall Time		$T_J=25^\circ\text{C}$	-	56	-	ns
			$T_J=175^\circ\text{C}$	-	63	-	ns
$E_{on}$	Turn-on Switching Energy		$T_J=25^\circ\text{C}$	-	4.5	-	mJ
			$T_J=175^\circ\text{C}$	-	4.7	-	mJ
$E_{off}$	Turn-off Switching Energy	$T_J=25^\circ\text{C}$	-	1.7	-	mJ	
		$T_J=175^\circ\text{C}$	-	1.9	-	mJ	

Symbol	Parameter	Test Conditions	Min	Typ	Max	Unit	Note
--------	-----------	-----------------	-----	-----	-----	------	------

**Gate Charge Characteristics**

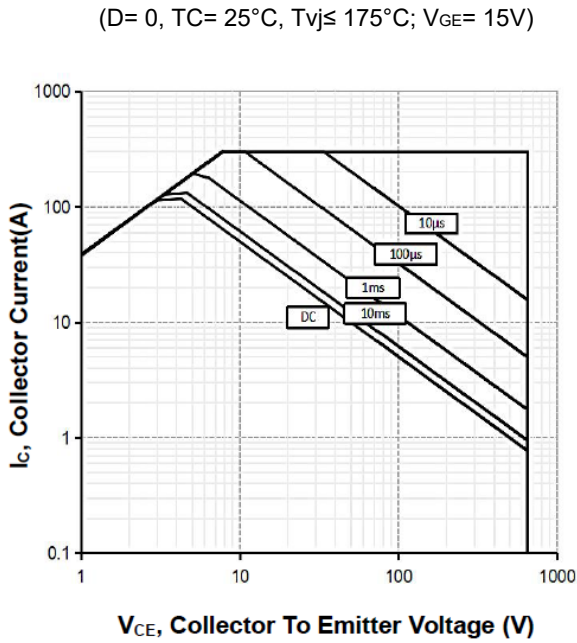
$Q_g$	Gate Charge Total	$V_{CC}=520V,$ $I_C=75A V_{GE}=0 \text{ to } 15V$	-	333	-	nC	
-------	-------------------	--	---	-----	---	----	--

**Drain-Source Body Diode Characteristics**

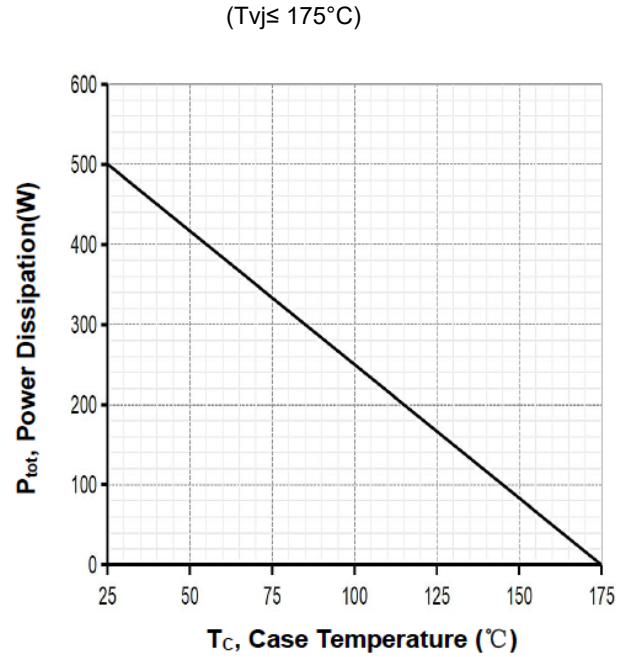
$V_F$	Diode Forward Voltage	$I_C = 75A, T_j = 25\text{ }^\circ\text{C}$	-	1.55	3	V	Fig.13
		$I_C = 75A, T_j = 175\text{ }^\circ\text{C}$	-	1.4	-		
$T_{rr}$	Reverse Recovery Time	$V_R=400V, I_F=75A$ $diF/dt = 500A/us, T_j = 25\text{ }^\circ\text{C}$	-	95	-	ns	Fig.14 15 16
$Q_{rr}$	Reverse Recovery Charge		-	1.0	-	uC	
$I_{rr}$	Diode Peak Reverse Recovery Current		-	18.3	-	A	

**Typical Performance Characteristics**

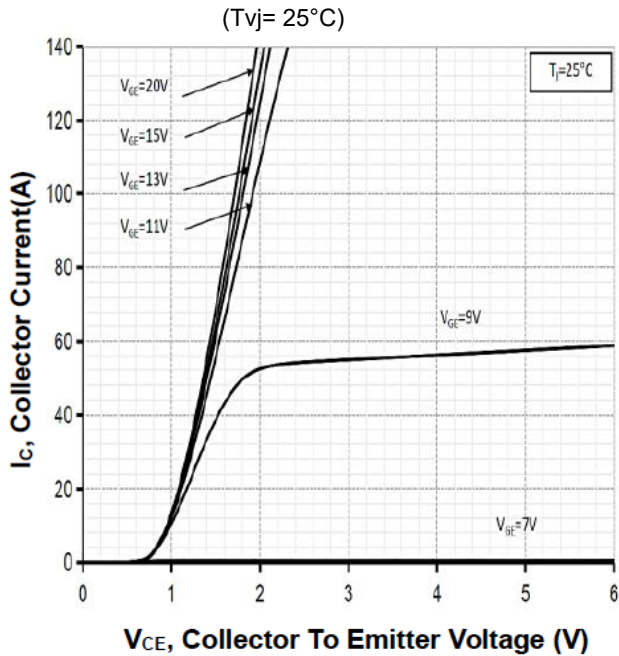
**Figure 1. Forward bias safe operating area**



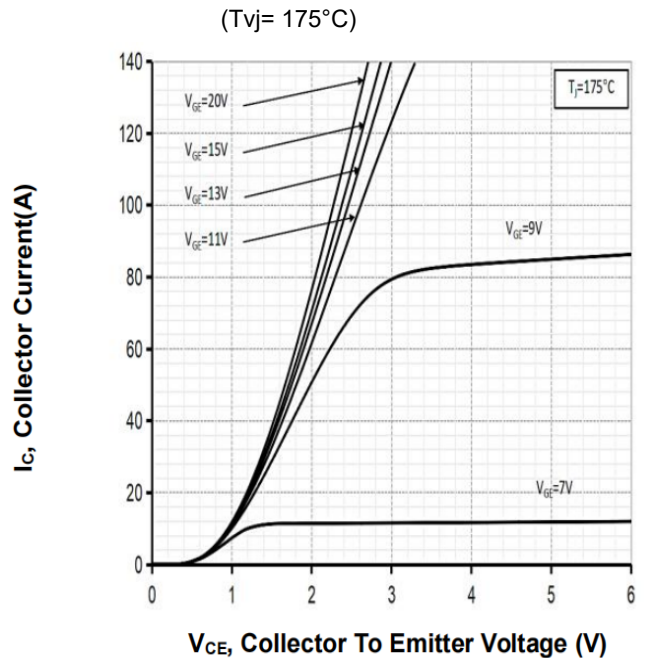
**Figure 2. Power dissipation vs. case temperature**



**Figure 3. Typical output characteristic**

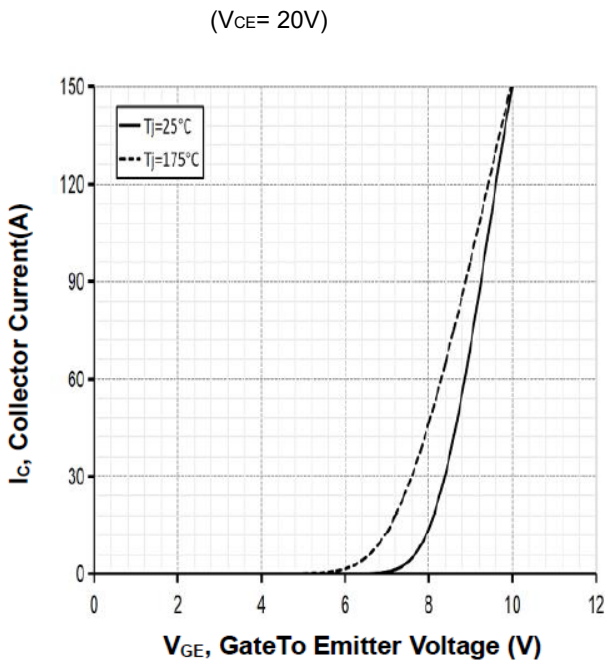


**Figure 4. Typical output characteristic**

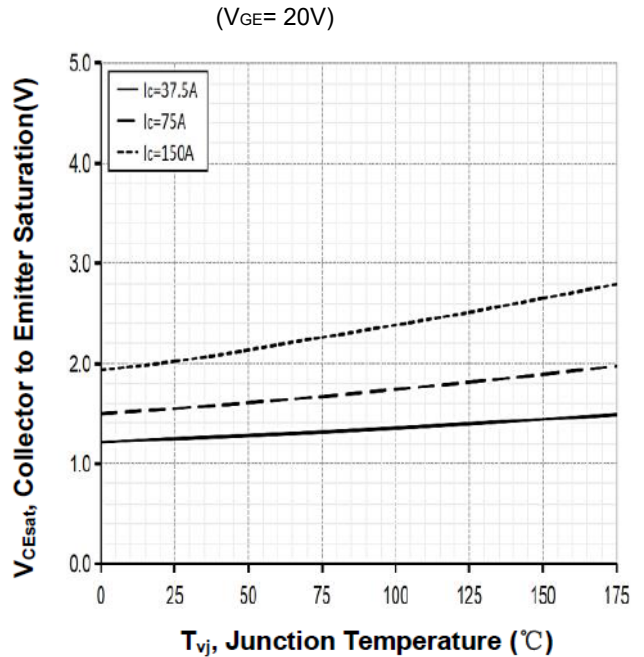


**Typical Performance Characteristics**

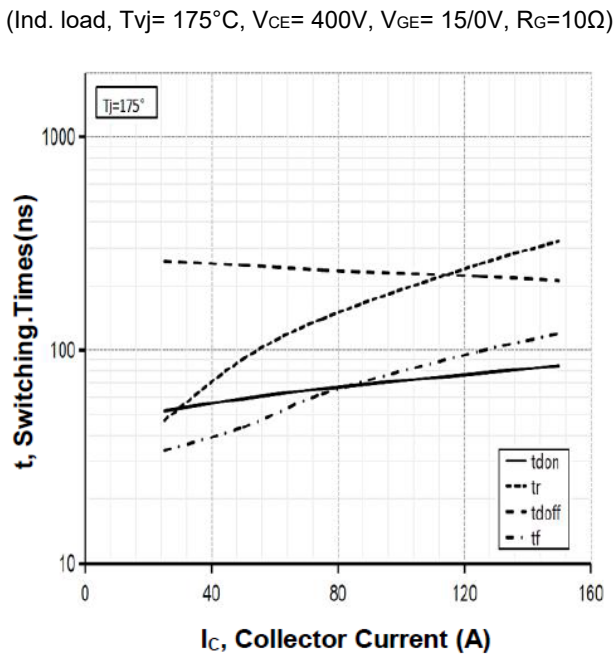
**Figure 5. Typical transfer characteristic**



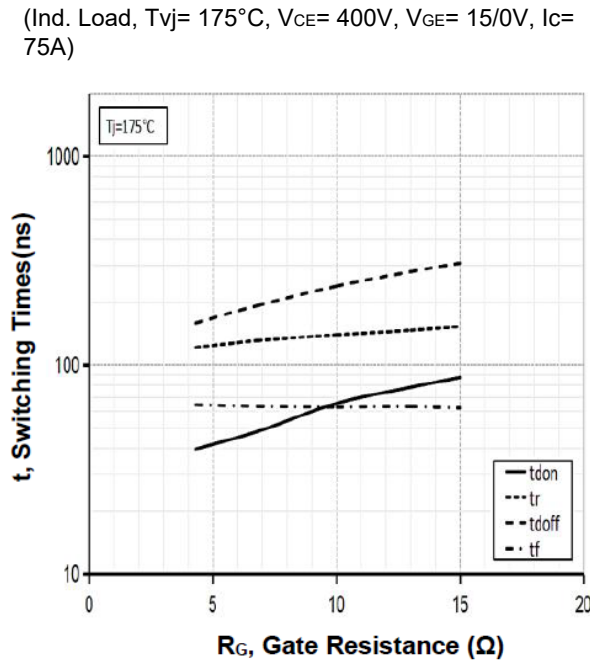
**Figure 6. Typical collector-emitter saturation voltage vs.  $T_{vj}$**



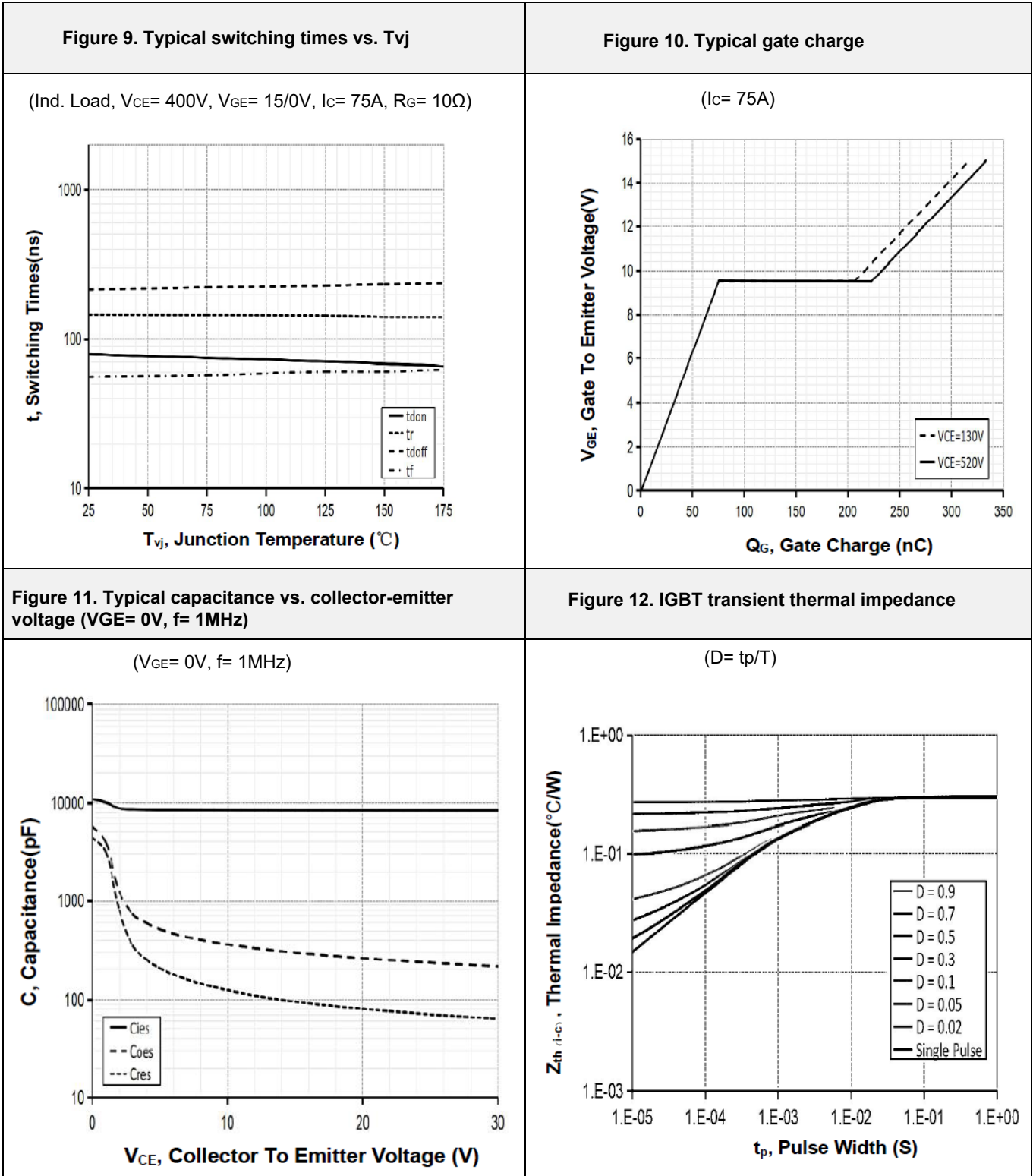
**Figure 7. Typical switching times vs. collector current**



**Figure 8. Typical switching times vs. gate resistor**

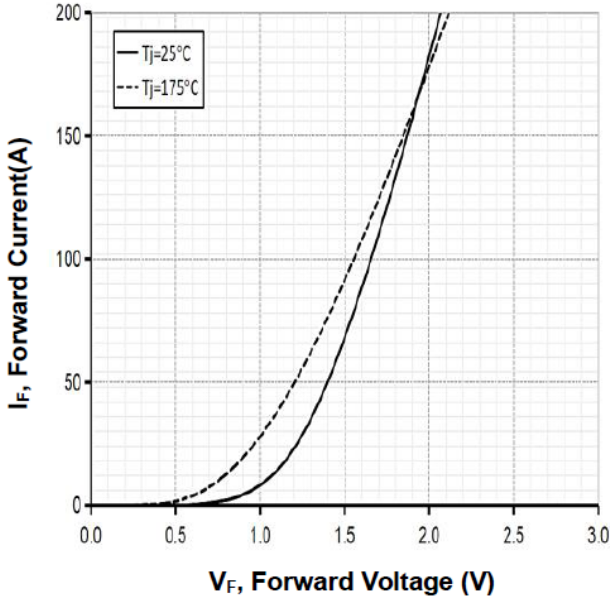


**Typical Performance Characteristics**

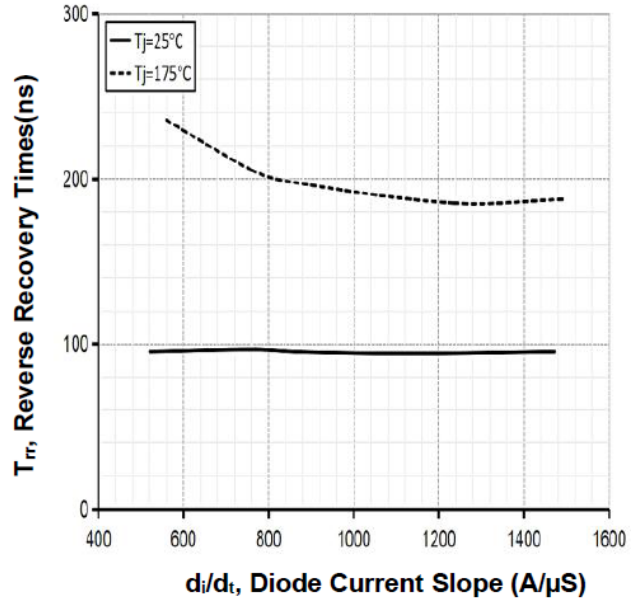


**Test Circuit**

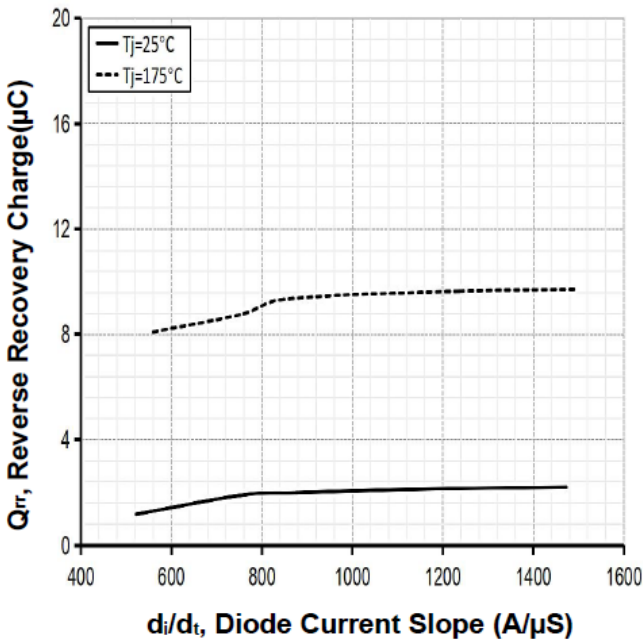
**Figure 13. Typical diode forward current vs. forward voltage**



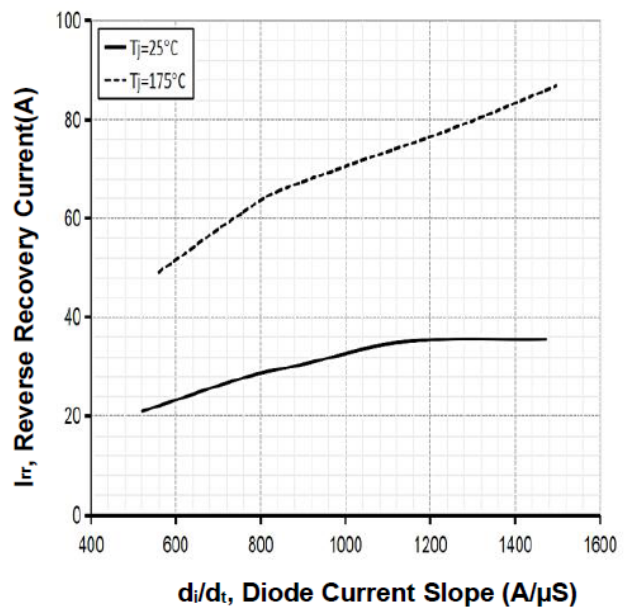
**Figure 14. Typical reverse recovery time vs. diode current slope ( $V_R = 400\text{V}$ )**



**Figure 15. Typical reverse recovery charge vs. diode current slope ( $V_R = 400\text{V}$ )**

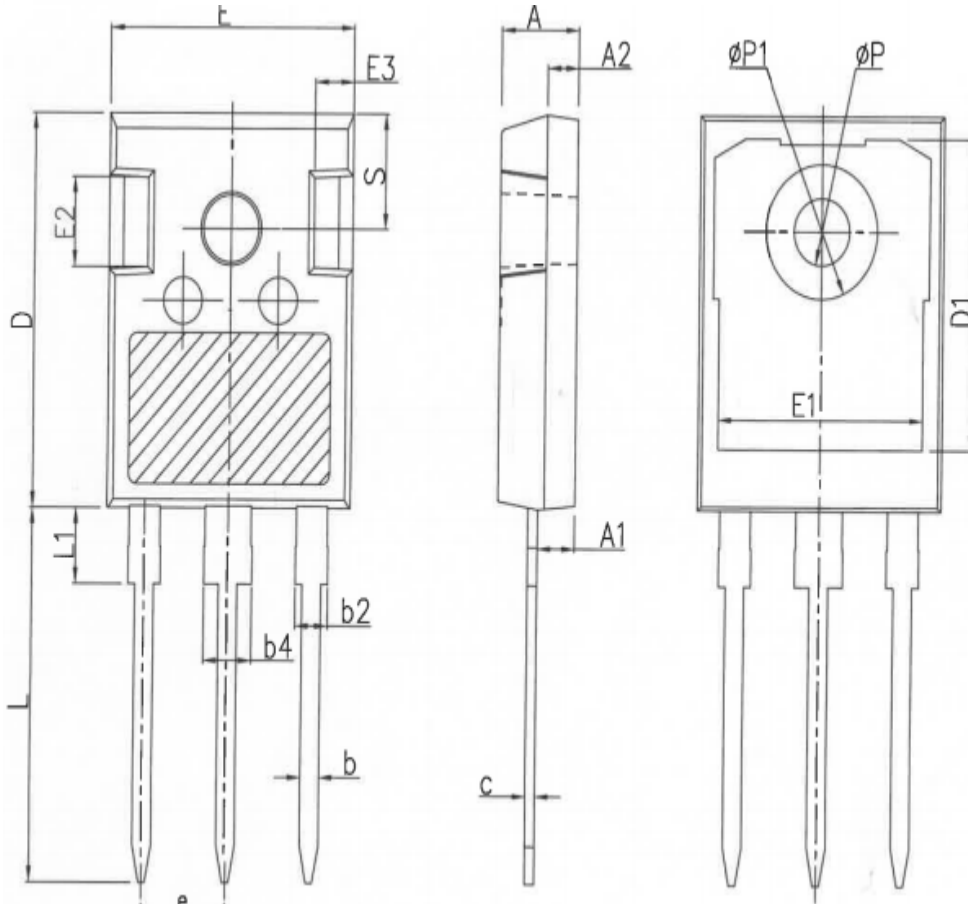


**Figure 16. Typical reverse recovery current vs. diode current slope ( $V_R = 400\text{V}$ )**



# Package Outlines

## TO247-3



COMMON DIMENSIONS

SYMBOL	mm		
	MIN	NOM	MAX
A	4.80	5.00	5.20
A1	2.21	2.41	2.59
A2	1.85	2.00	2.15
b	1.11	1.21	1.36
b2	1.91	2.01	2.21
b4	2.91	3.01	3.21
c	0.51	0.61	0.75
D	20.70	21.00	21.30
D1	16.25	16.55	16.85
E	15.50	15.80	16.10
E1	13.00	13.30	13.60
E2	4.80	5.00	5.20
E3	2.30	2.50	2.70
e	5.44BSC		
L	19.62	19.92	20.22
L1	-	-	4.30
$\phi P$	3.40	3.60	3.80
$\phi P1$	-	-	7.30
S	6.15BSC		

\* Dimensions in millimeters

## Package Marking and Ordering Information

Part Number	Top Marking	Package	Packing Method	Quantity
BKW65N75LZ1	BKW65N75LZ1	TO247-3L	Tube	30 units

## Disclaimer

Bestirpower reserve the right to make changes, corrections, enhancements, modifications, and improvements to Bestirpower products and/or to this document at any time without notice.

The information given in this document shall in no event be regarded as a guarantee of conditions or characteristics. Bestirpower does not assume any liability for infringement of patents, copyrights, or other intellectual property rights of third parties by or arising from the use of Products or technical information described in this document.

This document is the property of Bestirpower Co., LTD., and not allowed to copy or transformed to other format if not under the authority approval.

© 2026 bestirpower – All rights Reserved