

Fault Protected CAN Transceiver with CAN FD

Features

- Meets the ISO 11898-2:2016 and ISO 11898-5:2007 physical layer standards
- support classic CAN and CAN FD
- I/O Voltage range supports 3.3V and 5V MCUs
- Ideal passive behavior when unpowered
- ±15kV ESD Protection
- ±70V Bus Fault protection
- Undervoltage protection on V_{CC} & V_{IO} supply terminals
- Driver dominant time out
- Thermal shutdown protection
- Receiver common mode input voltage: ±30V
- SOP-8, MSOP-8 package and DFN-8 3x3 package

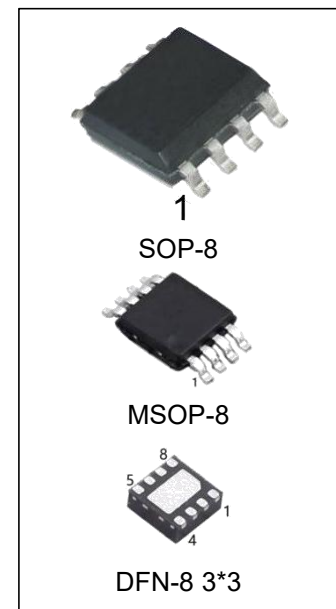

Ordering Information

DEVICE	Package Type	MARKING	Packing	Packing Qty
TJA1042M/TR-HG	SOP-8	A1042	REEL	2500pcs/reel
TJA1042M-3/TR-HG	SOP-8	A1042-3	REEL	2500pcs/reel
TJA1042MM/TR-HG	MSOP-8	A1042	REEL	3000pcs/reel
TJA1042MM-3/TR-HG	MSOP-8	A1042-3	REEL	3000pcs/reel
TJA1042DQ3/TR-HG	DFN-8 3*3	A1042	REEL	5000pcs/reel
TJA1042DQ3-3/TR-HG	DFN-8 3*3	A1042-3	REEL	5000pcs/reel

1. Description

The TJA1042 high-speed CAN transceiver provides an interface between a Controller Area Network (CAN) protocol controller and the physical two-wire CAN bus. The transceiver is designed for high-speed CAN applications in the automotive industry, providing the differential transmit and receive capability to a CAN protocol controller.

The TJA1042 offer offers improved EMC and ESD performance, and also features:

- Ideal passive behavior to the CAN bus when the supply voltage is off
- A very low-current Standby mode with bus wake- up capability
- Variants with a VIO pin can be interfaced directly with microcontrollers with supply voltages from 3.3V to 5V

The TJA1042 implements the CAN physical layer as defined in ISO 11898-2:2016 and SAE J2284-1 to SAE J2284-5. This implementation enables reliable communication in the CAN FD fast phase at data rates up to 5Mbps.

Applications

- All devices support highly loaded CAN networks
- Industrial automation, control, sensors and drive systems
- Building, security and climate control automation
- Telecom base station status and control

Functional Block Diagram

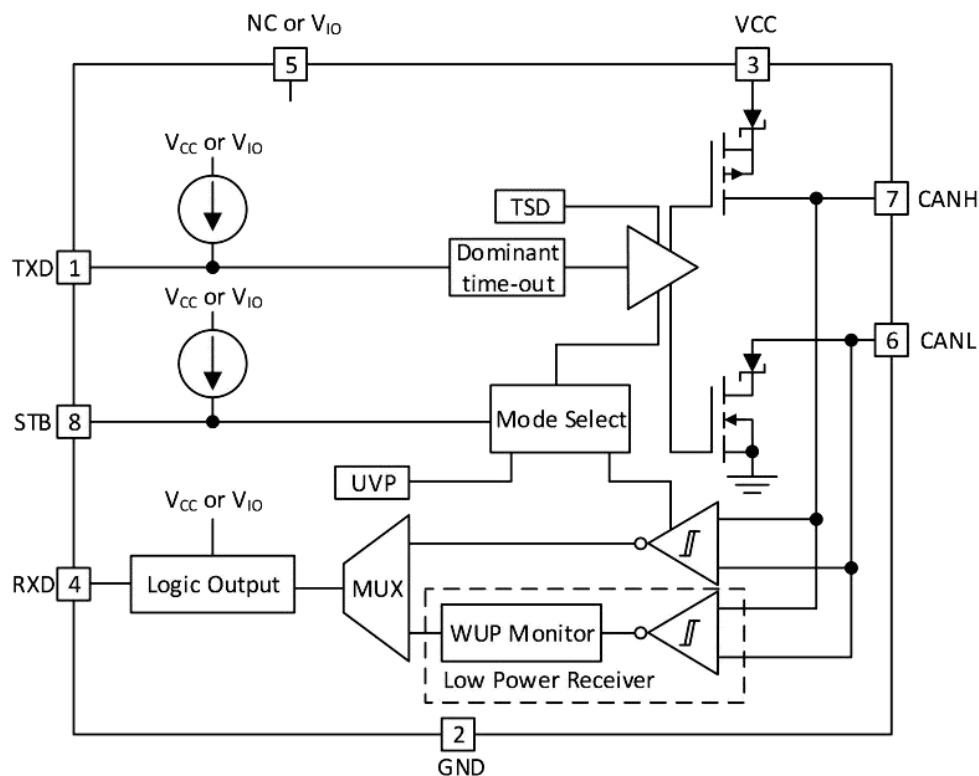

2. Pin Configurations and Functions

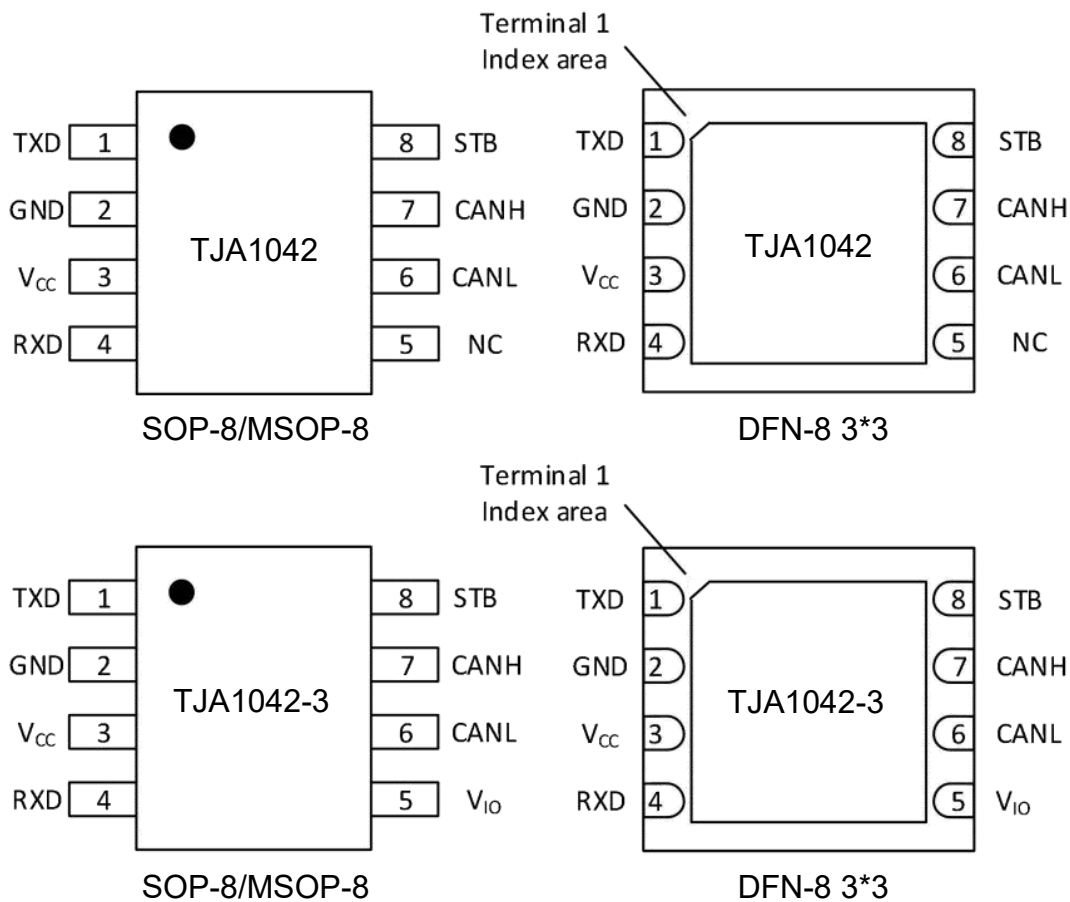

Pin Functions

Pins		TYP ⁽¹⁾	Description
Name	No.		
TXD	1	I	CAN transmit data input (LOW for dominant and HIGH for recessive bus states)
GND	2 ⁽²⁾	GND	Ground connection
V _{CC}	3	POWER	Transceiver 5V supply voltage
RXD	4	DIGITAL OUTPUT	CAN receive data output (LOW for dominant and HIGH for recessive bus states)
NC	5	-	No Connect
V _{IO}	5	P	Transceiver I/O level shifting supply voltage
CANL	6	AIO	Low level CAN bus input/output line
CANH	7	AIO	High level CAN bus input/output line
STB	8	I	Standby Mode control input (active high)

(1) I: digital input; O: digital output; AIO: analog input/output; P: power supply; G: ground.

(2) DFN-8 package die supply ground is connected to both the GND pin and the exposed center pad. The GND pin must be soldered to board ground. For enhanced thermal and electrical performance, it is recommended that the exposed center pad also be soldered to board ground.

3. Absolute Maximum Ratings

Parameter	Description	MIN	MAX	UNIT
V _{CC}	5V Supply Voltage Range ⁽¹⁾	-0.3	7	V
V _{IO}	I/O Level-Shifting Voltage Range	-0.3	7	V
V _{BUS}	CAN Bus I/O voltage range (CANH, CANL)	-70	70	V
V _I	Logic input terminal voltage range (TXD, S)	-0.5	6	V
V _O	Logic output terminal voltage range (RXD)	-0.5	6	V
I _{O(RXD)}	RXD (Receiver) output current	-8	8	mA
T _J	Junction temperature	-55	150	°C
T _{STG}	Storage temperatur	-65	150	°C
T _L	Lead Temperature (Soldering, 10 seconds)	-	260	°C

Note: Operation outside the Absolute Maximum Ratings may cause permanent device damage. Absolute Maximum Ratings do not imply functional operation of the device at these or any other conditions beyond those listed under Recommended Operating Conditions. If used outside the Recommended Operating Conditions but within the Absolute Maximum Ratings, the device may not be fully functional, and this may affect device reliability, functionality, performance, and shorten the device lifetime.

(1)All voltage values, except differential I/O bus voltages, are with respect to ground terminal.

ESD Ratings

	Test Conditions	VALUE	UNIT
Human Body Model (HBM) ESD stress voltage	All terminals	±8000	V
	CAN bus terminals (CANH, CANL)	±15000	
Charged Device Model (CDM) ESD stress voltage	All terminals	±2000	V
	IEC Contact Discharge (IEC 61000-4-2)	CAN bus terminals (CANH, CANL)	

Recommended Operating Conditions

		MIN	MAX	UNIT
V _{CC}	5V Bus Supply Voltage Range	4.5	5.5	V
V _{IO}	I/O Level-Shifting Voltage Range	3	5.5	
I _{OH(RXD)}	RXD terminal HIGH level output current	-2		mA
I _{OL(RXD)}	RXD terminal LOW level output current		2	

4. Electrical Characteristics

Over recommended operating conditions (unless otherwise noted).

Parameter		Test Conditions	Min	Typ ⁽¹⁾	Max	Unit	
Supply Characteristics							
I _{CC}	5V supply current	Normal mode (dominant)	See Figure 6-1, TXD = 0V, R _L = 60Ω, C _L = open, R _{CM} = open, STB = 0V, Typical Bus Load		40	70	mA
			See Figure 6-1, TXD = 0V, R _L = 50Ω, C _L = open, R _{CM} = open, STB = 0V, High Bus Load		45	80	
		Normal mode (dominant-with bus fault)	See Figure 6-1, TXD = 0V, STB = 0V, CANH = -12V, R _L = open, C _L = open, R _{CM} = open			180	
		Normal mode (recessive)	See Figure 6-1, TXD = V _{CC} or V _{IO} , R _L = 50Ω, C _L = open, R _{CM} = open, STB = 0V		0.6	1.0	
		Standby mode	V _{CC} not needed in Standby mode, See Figure 6-1, TXD = V _{IO} , R _L = 50Ω, C _L = open, R _{CM} = open, STB = V _{IO}		2.2	5	μA
I _{IO}	I/O supply current	Normal mode	RXD floating, TXD = STB = 0 or 5.5V		100	300	μA
		Standby mode	RXD floating, TXD = STB = V _{IO} , V _{CC} = 0 or 5.5V		12	17	
UV _{VCC}	Rising undervoltage detection on V _{CC} for protected mode		All devices		3.2	3.4	V
	Falling undervoltage detection on V _{CC} for protected mode				2.8	3.0	
V _{HYS(UVCC)}	Hysteresis voltage on UV _{VCC}				200		mV
UV _{VIO}	Undervoltage detection on V _{IO} for protected mode		Device with V _{IO} pin		1.3	2.75	V
V _{HYS(UVVIO)}	Hysteresis voltage on UV _{VIO} for protected mode					80	mV
STB Terminal (Mode Select Input)							
V _{IH}	High-level input voltage	Devices with V _{IO} pin	0.7V _{IO}			V	
		Devices without V _{IO} pin	2				
V _{IL}	Low-level input voltage	Devices with V _{IO} pin			0.3V _{IO}	V	
		Devices without V _{IO} pin			0.8		
I _{IH}	High-level input leakage current	STB = V _{CC} = V _{IO} = 5.5V	-2	0	2	μA	
I _{IL}	Low-level input leakage current	STB = 0V, V _{CC} = V _{IO} = 5.5V	-15	-10	-2		
I _{LKG(OFF)}	Unpowered leakage current	STB = 5.5V, V _{CC} = V _{IO} = 0V	-1	0	1		
TXD Terminal (CAN Transmit Data Input)							
V _{IH}	High-level input voltage	Devices with V _{IO} pin	0.7V _{IO}			V	
		Devices without V _{IO} pin	2				
V _{IL}	Low-level input voltage	Devices with V _{IO} pin			0.3V _{IO}	V	
		Devices without V _{IO} pin			0.8		
I _{IH}	High-level input leakage current	TXD = V _{CC} = V _{IO} = 5.5V	-2.5	0	1	μA	
I _{IL}	Low-level input leakage current	TXD = 0V, V _{CC} = V _{IO} = 5.5V	-100	-40	-7		
I _{LKG(OFF)}	Unpowered leakage current	TXD = 5.5V, V _{CC} = V _{IO} = 0V	-1	0	1		

RXD Terminal (Can Receive Data Output)							
V _{OH}	High-level output voltage	Devices with V _{IO} pin, See Figure 6-2, I _o = -2mA.		0.8V _{IO}			V
		Devices without V _{IO} pin, See Figure 6-2, I _o = -2mA.		4	4.6		
V _{OL}	Low-level output voltage	Devices with V _{IO} pin, See Figure 6-2, I _o = +2mA.				0.2V _{IO}	V
		Devices without V _{IO} pin, See Figure 6-2, I _o = +2mA.			0.2	0.4	
I _{LKG(OFF)}	Unpowered leakage current	RXD = 5.5V, V _{CC} = 0V, V _{IO} = 0V		-1	0	-1	μA
Driver Electrical Characteristics							
V _{O(DOM)}	Bus output voltage (dominant)	CANH	See Figure 6-1 and Figure 7-3, TXD = 0V, STB = 0V, 50Ω ≤ R _L ≤ 65Ω, C _L = open, R _{CM} = open	2.75	3.6	4.5	V
		CANL		0.5	1.4	2.25	
V _{O(REC)}	Bus output voltage(recessive)	CANHand CANL	See Figure 6-1 and Figure 7-3, TXD = V _{CC} or V _{IO} , V _{IO} = V _{CC} , STB = 0V, R _L = open (no load), R _{CM} = open	2	0.5V _{CC}	3	V
V _{O(STB)}	Bus output Voltage (Standby mode)	CANH	See Figure 6-1 and Figure 7-3, STB = V _{IO} , R _L = open (no load), R _{CM} = open	-0.1	0	0.1	
		CANL		-0.1	0	0.1	
		CANH -CANL		-0.2	0	0.2	
V _{OD(DOM)}	Differential output voltage (dominant)	CANH - CANL	See Figure 6-1 and Figure 7-3, TXD = 0V, STB = 0V, 45Ω ≤ R _L < 50Ω, C _L = open, R _{CM} = open	1.4		3	V
			See Figure 6-1 and Figure 7-3, TXD = 0V, STB = 0V, 50Ω ≤ R _L ≤ 65Ω, C _L = open, R _{CM} = open	1.5	2.2	3	
			See Figure 6-1 and Figure 7-3, TXD = 0V, STB = 0V, R _L = 2240Ω, C _L = open, R _{CM} = open	1.5		5	
V _{OD(REC)}	Differential output voltage (recessive)	CANH - CANL	See Figure 6-1 and Figure 7-3, TXD = V _{CC} , STB = 0V, R _L = 60Ω, C _L = open, R _{CM} = open	-120		20	mV
			See Figure 6-1 and Figure 7-3, TXD = V _{CC} , STB = 0V, R _L = open (no load), C _L = open, R _{CM} = open	-50		50	
V _{SYM}	Output symmetry (dominant or recessive) (V _{O(CANH)} + V _{O(CANL)}) / V _{CC}		See Figure 6-1 and Figure 8-2, STB at 0V, R _{term} = 60Ω, C _{split} = 4.7nF, C _L = open, R _{CM} = open, TXD = 250kHz, 1MHz	0.9		1.1	V/V
V _{SYM_DC}	DC Output symmetry (dominant or recessive) (V _{CC} - V _{O(CANH)} - V _{O(CANL)})		See Figure 6-1 and Figure 7-3, STB = 0V, R _L = 60Ω, C _L = open, R _{CM} = open	-0.4		0.4	V
I _{OS(SS_DOM)}	Short-circuit steady-state output current, dominant, Normal mode		See Figure 7-3, STB at 0V, V _{CANH} = -5V to 40V, C _{ANL} = open, TXD = 0V	-100			mA
			See Figure 7-3, STB at 0V, V _{CANL} = -5V to 40V, C _{ANH} = open, TXD = 0V	100			
I _{OS(SS_REC)}	Short-circuit steady-state output current, recessive, Normal mode		See Figure 7-3, STB at 0V, -27V ≤ V _{BUS} ≤ 32V, Where V _{BUS} = C _{ANH} = C _{ANL} , TXD = V _{CC}	-5		5	mA
Receiver Electrical Characteristics							
V _{CM}	Common mode range, Normal mode		See Figure 6-2 and Table 6-1, STB = 0V	-30		+30	V

V_{IT+}	Positive-going input threshold voltage, Normalmode	See Figure 6-2, Table 7-5 and Table 6-1, STB = 0V, $-20V \leq V_{CM} \leq +20V$			900	mV
V_{IT-}	Negative-going input threshold voltage, Normalmode		500			
V_{IT+}	Positive-going input threshold voltage, Normalmode	See Figure 6-2, Table 7-5 and Table 6-1, STB = 0V, $-30V \leq V_{CM} \leq +30V$			1000	
V_{IT-}	Negative-going input threshold voltage, Normalmode		400			
V_{HYS}	Hysteresis voltage ($V_{IT+} - V_{IT-}$), Normal mode	See Figure 6-2, Table 7-5 and Table 6-1, STB = 0V		120		
V_{CM}	Common mode range, Standby mode	Devices with V_{IO} pin, See Figure 6-2, Table 7-5 and Table 6-1, STB = V_{IO} , $4.5V \leq V_{IO} \leq 5.5V$	-12		12	V
		Devices with V_{IO} pin, See Figure 6-2, Table 7-5 and Table 6-1, STB = V_{IO} , $3.0V \leq V_{IO} \leq 4.5V$	-2		7	
		Devices without V_{IO} pin, See Figure 6-2, Table 7-5 and Table 6-1, STB = V_{CC}	-12		12	
$V_{IT(STANDBY)}$	Input threshold voltage, Standby mode	STB = V_{CC} or V_{IO}	400		1150	mV
$I_{LKG(OFF)}$	Power-off (unpowered) bus input leakage current	CANH = CANL = 5V, $V_{CC} = V_{IO} = 0V$			4.8	μA
R_{ID}	Differential input resistance	TXD = $V_{CC} = V_{IO} = 5V$, STB = 0V, $-30V \leq V_{CM} \leq +30V$	20	30	50	k Ω
R_{IN}	Input resistance (CANH or CANL)		10	15	25	
$R_{IN(M)}$	Input resistance matching: $[1 - (R_{IN(CANH)} / R_{IN(CANL)})] \times 100\%$		$V_{CANH} = V_{CANL} = 5V$	-2%		

(1) All typical values are at 25°C and supply voltages of $V_{CC} = 5V$ and $V_{IO} = 5V$ (if applicable), $R_L = 60\Omega$.

5. Switching Characteristics

Over recommended operating conditions (unless otherwise noted)

Parameter		Test Conditions	Min	Typ ⁽¹⁾	Max	Unit
Device Switching Characteristics						
$t_{PROP(LOOP1)}$	Total loop delay, driver input (TXD) to receiver output (RXD), recessive to dominant	STB = 0V, $R_L = 60\Omega$ $C_L = 100pF$ $C_{L(RXD)} = 15pF$		110	160	ns
$t_{PROP(LOOP2)}$	Total loop delay, driver input (TXD) to receiver output (RXD), dominant to recessive			130	200	
t_{MODE}	Mode change time, from Normal to Standby or from Standby to Normal			20	45	μs
$t_{filter(wake)bus}$	Bus wake-up filter time	Version with NC pin Standby mode	0.5	1	35	μs
		Version with V_{IO} pin Standby mode	0.5	1.5	5	
Driver Switching Characteristics						
t_{pHR}	Propagation delay time, high TXD to driver recessive (dominant to recessive)	See Figure 6-1 STB = 0V, $R_L = 60\Omega$ $C_L = 100pF$ $R_{CM} = open$		80		ns
t_{pLD}	Propagation delay time, low TXD to driver dominant (recessive to dominant)			65		
$t_{sk(p)}$	Pulse skew ($ t_{pHR} - t_{pLD} $)			15		
t_R	Differential output signal rise time			45		
t_F	Differential output signal fall time			45		
t_{TXD_DTO}	Dominant timeout	STB = 0V, $R_L = 60\Omega$ $C_L = open$	1.2	2	3.8	ms
Receiver Switching Characteristics						
t_{pRH}	Propagation delay time, bus recessive input to high output (Dominant to Recessive)	See Figure 6-2 STB = 0V $C_{L(RXD)} 15pF$		55		ns
t_{pDL}	Propagation delay time, bus dominant input to low output (Recessive to Dominant)			55		ns
t_R	RXD Output signal rise time			10		ns
t_F	RXD Output signal fall time			10		ns

(1) All typical values are at 25°C and supply voltages of $V_{CC} = 5V$ and $V_{IO} = 5V$ (if applicable), $R_L = 60\Omega$

6. Parameter Measurement Information

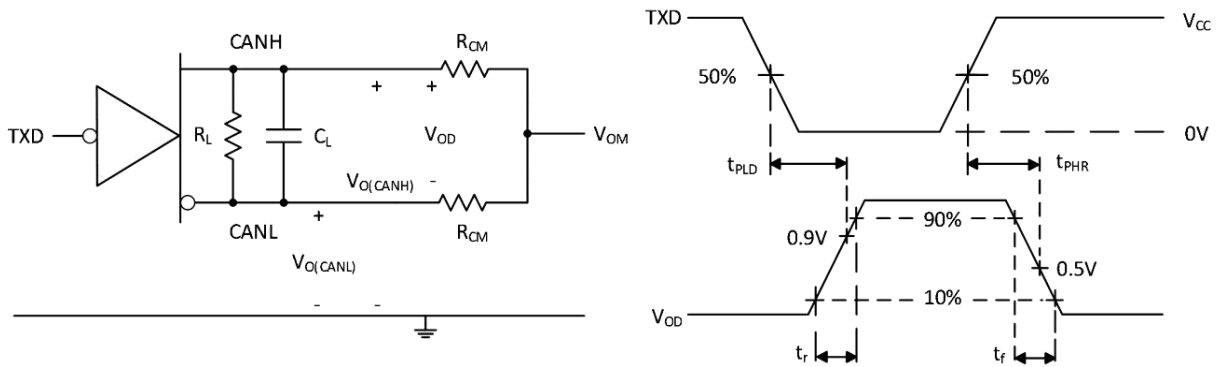

Figure 6-1. Driver Test Circuit and Measurement

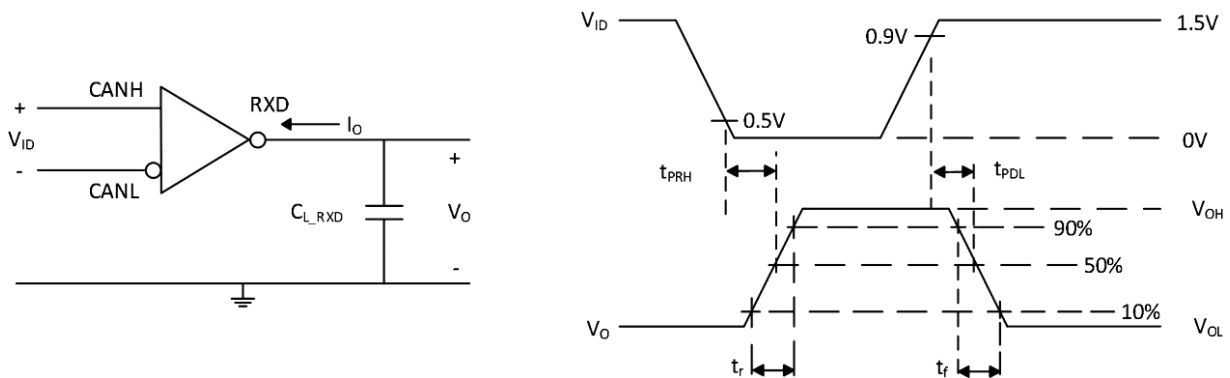

Figure 6-2. Receiver Test Circuit and Measurement

Table 6-1. Receiver Differential Input Voltage Threshold Test

INPUT			OUTPUT	
V_{CANH}	V_{CANL}	$ V_{ID} $	R_{XD}	
-29.5 V	-30.5 V	1000 mV	L	V_{OL}
30.5 V	29.5 V	1000 mV	L	
-19.55 V	-20.45 V	900 mV	L	
20.45 V	19.55 V	900 mV	L	
-19.75 V	-20.25 V	500 mV	H	V_{OH}
20.25 V	19.75 V	500 mV	H	
-29.8 V	-30.2 V	400 mV	H	
30.2 V	29.8 V	400 mV	H	
Open	Open	X	H	

7. Detailed Description

Overview

These CAN transceivers meet the ISO11898-2 (2016) High Speed CAN (Controller Area Network) physical layer standard. They are designed for data rates in excess of 1 Mbps for CAN FD and enhanced timing margin/higher data rates in long and highly-loaded networks. These devices provide many protection features to enhance device and CAN robustness.

Functional Block Diagram

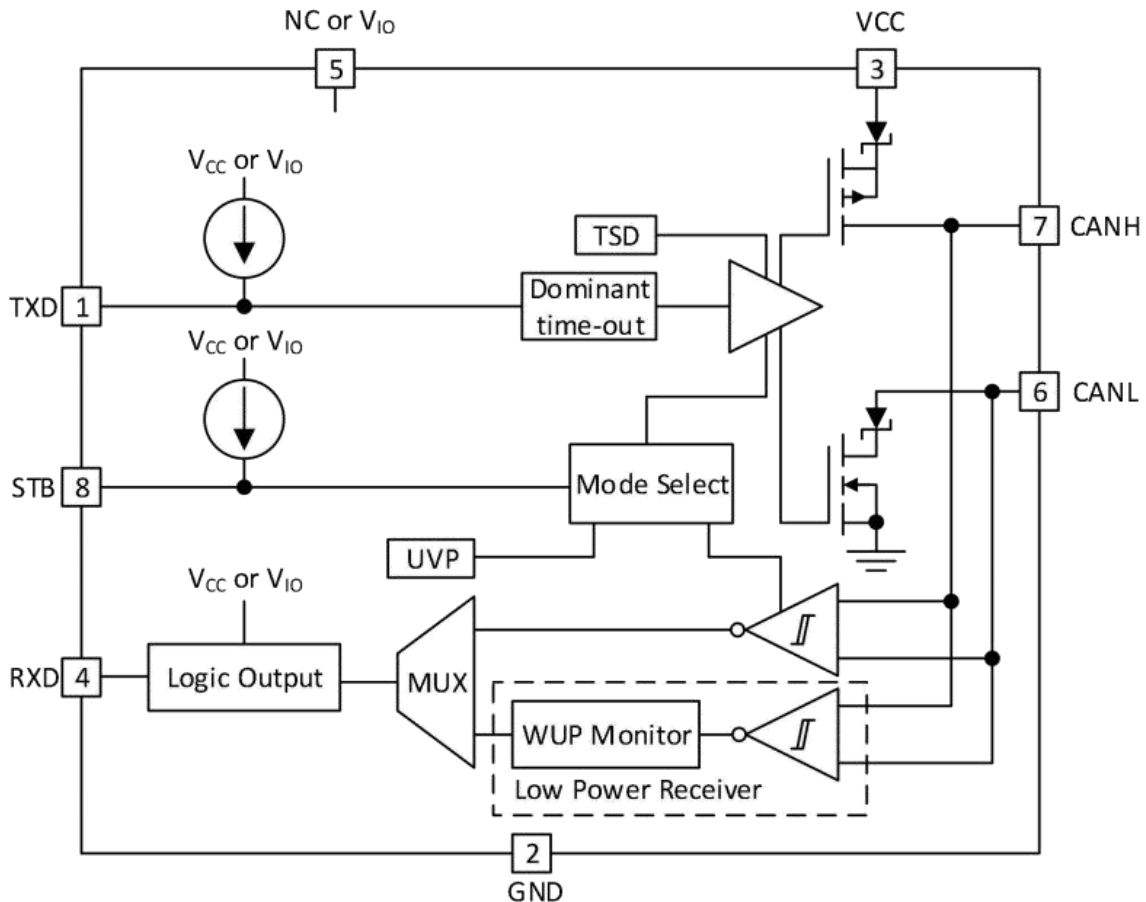

Feature Description

TXD Dominant Timeout (DTO)

During normal mode (the only mode where the CAN driver is active), the TXD DTO circuit prevents the transceiver from blocking network communication in the event of a hardware or software failure where TXD is held dominant longer than the timeout period t_{TXD_DTO} . The DTO circuit timer starts on a falling edge on TXD. The DTO circuit disables the CAN bus driver if no rising edge is seen before the timeout period expires. This frees the bus for communication between other nodes on the network. The CAN driver is re-activated when a recessive signal is seen on the TXD terminal, thus clearing the TXD DTO condition. The receiver and RXD terminal still reflect activity on the CAN bus, and the bus terminals are biased to the recessive level during a TXD dominant timeout.

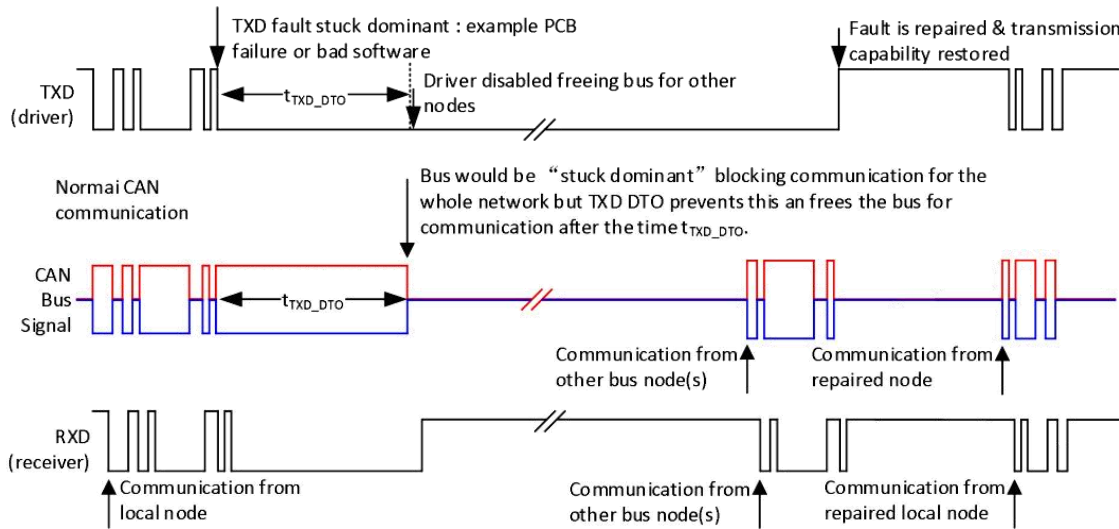

Figure 7-1. Example Timing Diagram for TXD DTO

Thermal Shutdown (TSD)

If the junction temperature of the device exceeds the thermal shutdown threshold (T_{TSD}), the device turns off the CAN driver circuits thus blocking the TXD-to-bus transmission path. The CAN bus terminals are biased to the recessive level during a thermal shutdown, and the receiver-to-RXD path remains operational. The shutdown condition is cleared when the junction temperature drops at least the thermal shutdown hysteresis temperature (T_{TSD_HYS}) below the thermal shutdown temperature (T_{TSD}) of the device.

Undervoltage Lockout

The supply terminals have undervoltage detection that places the device in protected mode. This protects the bus during an undervoltage event on either the V_{CC} or V_{IO} supply terminals.

Table 7-1. Undervoltage Lockout 5V Only Devices without V_{IO} pin

Table 7-1. Undervoltage Lockout 5V Only Devices without V_{IO} pin

VCC	Device State ⁽¹⁾	Bus Output	RXD
$> UV_{VCC}$	Normal	Per TXD	Mirrors Bus ⁽²⁾
$< UV_{VCC}$	Protected	High Impedance	High Impedance

(1) See the V_{IT} section of the Electrical Characteristics.

(2) Mirrors bus state: low if CAN bus is dominant, high if CAN bus is recessive.

Table 7-2. Undervoltage Lockout only I/O Devices with V_{IO} pin

VCC	VIO	Device State	Bus Output	RXD
$> UV_{VCC}$	$> UV_{VIO}$	Normal	Per TXD	Mirrors Bus ⁽¹⁾
$< UV_{VCC}$	$> UV_{VIO}$	STB = High: Standby Mode	Recessive	Bus Wake RXD Request ⁽²⁾
		STB = Low: Protected Mode	High Impedance	High (Recessive)
$> UV_{VCC}$	$< UV_{VIO}$	Protected	High Impedance	High Impedance
$< UV_{VCC}$	$< UV_{VIO}$	Protected	High Impedance	High Impedance

(1) Mirrors bus state: low if CAN bus is dominant, high if CAN bus is recessive.

(2) Refer to Section 7.4.3.1

Unpowered Device

The device is designed to be 'ideal passive' or 'no load' to the CAN bus if it is unpowered. The bus terminals (CANH, CANL) have extremely low leakage currents when the device is unpowered to avoid loading down the bus. This is critical if some nodes of the network are unpowered while the rest of the of network remains in operation. The logic terminals also have extremely low leakage currents when the device is unpowered to avoid loading down other circuits that may remain powered.

Floating Terminals

These devices have internal pull ups on critical terminals to place the device into known states if the terminals float. The TXD terminal is pulled up to V_{CC} or V_{IO} to force a recessive input level if the terminal floats. The STB terminal is also pulled up to force the device into low power Standby mode if the terminal floats.

CAN Bus Short Circuit Current Limiting

The device has two protection features that limit the short circuit current when a CAN bus line is short-circuit fault condition: driver current limiting (both dominant and recessive states) and TXD dominant state time out to prevent permanent higher short circuit current of the dominant state during a system fault. During CAN communication the bus switches between dominant and recessive states, thus the short circuit current may be viewed either as the instantaneous current during each bus state or as an average current of the two states.

Digital Inputs and Outputs

Devices without V_{IO} pin:

The 5V V_{CC} only devices are supplied by a single 5V rail. The digital inputs have T_{TL} input thresholds and are therefore 5V and 3.3V compatible. The RXD outputs on these devices are driven to the V_{CC} rail for logic high output. Additionally, the TXD and STB pins are internally pulled up to V_{CC} . The internal bias of the mode pins may only place the device into a known state if the terminals float, they may not be adequate for system-level biasing during transients or noisy environments.

Devices with V_{IO} pin:

These devices use a 5V V_{CC} power supply for the CAN driver and high speed receiver blocks. These transceivers have a second power supply for I/O level-shifting (V_{IO}). This supply is used to set the CMOS input thresholds of the TXD and STB pins and the RXD high level output voltage. Additionally, the internal pull ups on TXD and STB are pulled up to V_{IO} .

Device Functional Modes

The device has two main operating modes: Normal mode and Standby mode. Operating mode selection is made via the STB input terminal.

Table 7-3. Operating Modes

Mode	STB Terminal	RXD	
		LOW	HIGH
Normal Mode	LOW	Bus dominant	Bus recessive
Standby Mode	HIGH	Wake-up request detected	No wake-up request detected

CAN Bus States

The CAN bus has two states during powered operation of the device: dominant and recessive. A dominant bus state is when the bus is driven differentially, corresponding to a logic low on the TXD and RXD terminal. A recessive bus state is when the bus is biased to $V_{CC}/2$ via the high-resistance internal input resistors R_{IN} of the receiver, corresponding to a logic high on the TXD and RXD terminals.

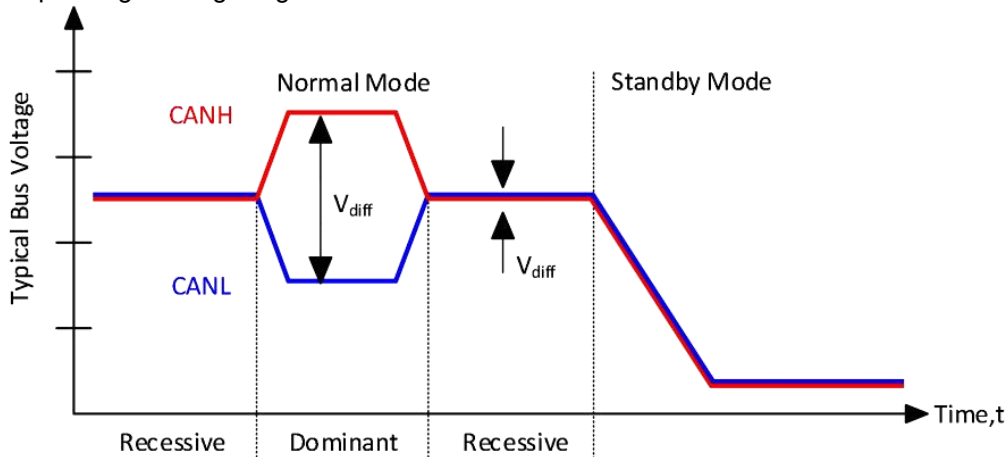
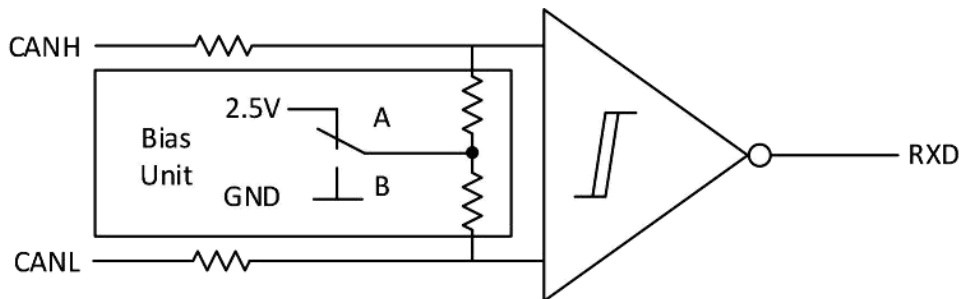

Figure 7-2. Bus States (Physical Bit Representation)



- A: Normal Modes
- B: Standby Mode (Low Power)

Figure 7-3. Bias Unit (Recessive Common Mode Bias) and Receiver

Normal Mode

Select the Normal mode of device operation by setting STB terminal low. The CAN driver and receiver are fully operational and CAN communication is bi-directional. The driver translates a digital input on TXD to a differential output on CANH and CANL. The receiver translates the differential signal from CANH and CANL to a digital output on RXD.

Standby Mode

A HIGH level on pin STB selects Standby mode. In Standby mode, the transceiver is not able to transmit or correctly receive data via the bus lines. The transmitter and Normal-mode receiver blocks are switched off to reduce supply current, and only a low-power differential receiver monitors the bus lines for activity. The wake-up filter on the output of the low-power receiver does not latch bus dominant states, but ensures that only bus dominant and bus recessive states that persist longer than $t_{\text{ftr(wake)bus}}$ are reflected on pin RXD.

In Standby mode, the bus lines are biased to ground to minimize the system supply current. The low-power receiver is supplied by V_{IO} , and is capable of detecting CAN bus activity even if V_{IO} is the only supply voltage available. When pin RXD goes LOW to signal wake-up request, a transition to Normal mode will not be triggered until STB is forced LOW

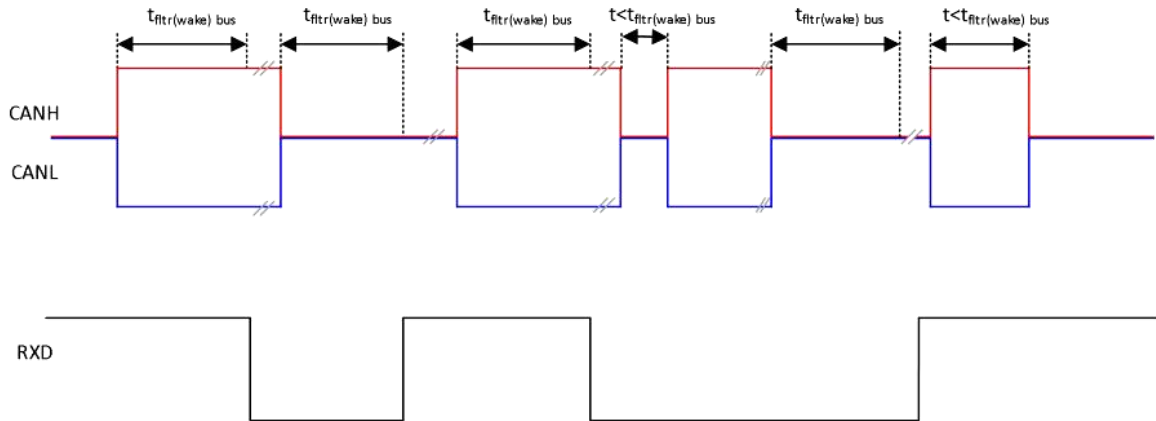
Figure 7-4. Wake Up Pattern (WUP)
Driver and Receiver Function Tables
Table 7-4. Driver Function Table

Device	Inputs		Outputs		Driven Bus State
	STB ⁽¹⁾	TXD ^{(1) (2)}	CANH ⁽¹⁾	CANL ⁽¹⁾	
All Devices	L	L	H	L	Dominant
		H or Open	Z	Z	Recessive
	H or Open	X	Z	Z	Recessive

(1) H = high level, L = low level, X = irrelevant, Z = common mode (recessive) bias to $V_{CC}/2$. See CAN Bus States for bus state and common mode bias information.

(2) Devices have an internal pull up to V_{CC} or V_{IO} on TXD terminal. If the TXD terminal is open, the terminal is pulled high and the transmitter remain in recessive (non-driven) state.

Table 7-5. Receiver Function Table

Device mode	CAN Differential Inputs $V_{ID}=V_{CANH} - V_{CANL}$	Bus State	RXD Terminal ⁽¹⁾
Normal	$V_{ID} \geq V_{IT+(MAX)}$	Dominant	L ⁽²⁾
	$V_{IT-(MIN)} < V_{ID} < V_{IT+(MAX)}$?	? ⁽²⁾
	$V_{ID} \leq V_{IT-(MIN)}$	Recessive	H ⁽²⁾
	Open ($V_{ID} \approx 0V$)	Open	H

(1) H = high level, L = low level, ? = indeterminate.

(2) See Receiver Electrical Characteristics section for input thresholds.

8. Application and Implementation

Application Information

These CAN transceivers are typically used in applications with a host microprocessor or FPGA that includes the data link layer portion of the CAN protocol. Below are typical application configurations for both 5V and 3.3V microprocessor applications. The bus termination is shown for illustrative purposes.

Typical Applications

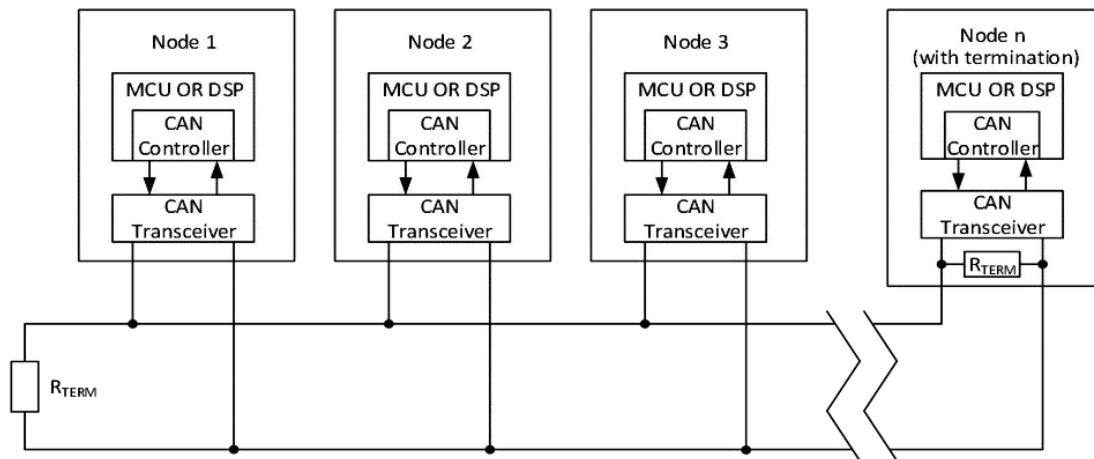

Figure 8-1. Typical CAN Bus Application

Design Requirements

Bus Loading, Length and Number of Nodes

The ISO 11898-2 Standard specifies a maximum bus length of 40 m and maximum stub length of 0.3 m. However, with careful design, users can have longer cables, longer stub lengths, and many more nodes to a bus. A large number of nodes requires transceivers with high input impedance such as the TJA1042 family of transceivers.

Many CAN organizations and standards have scaled the use of CAN for applications outside the original ISO 11898-2. They have made system-level trade-offs for data rate, cable length, and parasitic loading of the bus. Examples of some of these specifications are ARINC825, CANopen, DeviceNet and NMEA2000.

The TJA1042 family is specified to meet the 1.5V requirement with a 50Ω load, incorporating the worst case including parallel transceivers. The differential input resistance of the TJA1042 family is a minimum of 30kΩ. If 100 TJA1042 family transceivers are in parallel on a bus, this is equivalent to a 300Ω differential load worst case. That transceiver load of 300Ω in parallel with the 60Ω gives an equivalent loading of 50Ω. Therefore, the TJA1042 family theoretically supports up to 100 transceivers on a single bus segment. However, for CAN network design margin must be given for signal loss across the system and cabling, parasitic loadings, network imbalances, ground offsets and signal integrity thus a practical maximum number of nodes is typically much lower. Bus length may also be extended beyond the original ISO 11898 standard of 40 m by careful system design and data rate tradeoffs. For example, CANopen network design guidelines allow the network to be up to 1 km with changes in the termination resistance, cabling, less than 64 nodes and significantly lowered data rate.

This flexibility in CAN network design is one of the key strengths of the various extensions and additional standards that have been built on the original ISO 11898-2 CAN standard. In using this flexibility comes the responsibility of good network design and balancing these tradeoffs.

Detailed Design Procedures

CAN Termination

The ISO 11898 standard specifies the interconnect to be a twisted pair cable (shielded or unshielded) with 120Ω characteristic impedance (Z_0). Resistors equal to the characteristic impedance of the line should be used to terminate both ends of the cable to prevent signal reflections. Unterminated drop lines (stubs) connecting nodes to the bus should be kept as short as possible to minimize signal reflections. The termination may be on the cable or in a node, but if nodes may be removed from the bus, the termination must be carefully placed so that two terminations always exist on the network.

Termination may be a single 120Ω resistor at the end of the bus, either on the cable or in a terminating node. If filtering and stabilization of the common mode voltage of the bus is desired, then split termination may be used. (See Figure 8-2). Split termination improves the electromagnetic emissions behavior of the network by eliminating fluctuations in the bus common-mode voltages at the start and end of message transmissions.

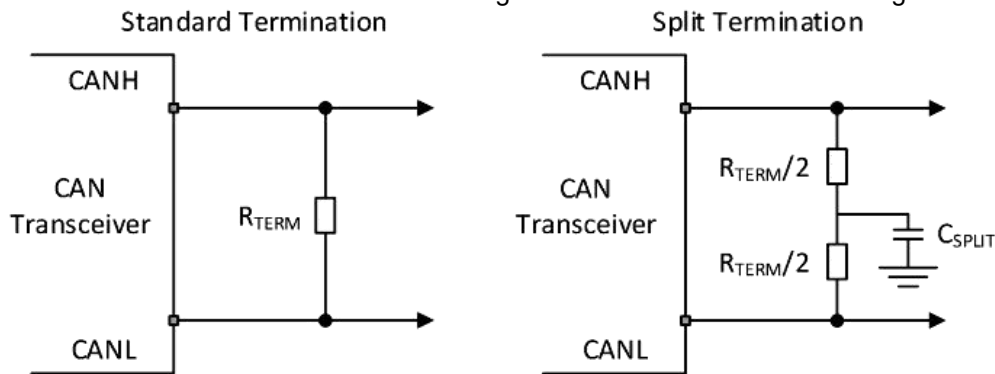

Figure 8-2. CAN Bus Termination Concepts

The family of transceivers have variants for both 5V only applications and applications where level shifting is needed for a 3.3V microcontroller

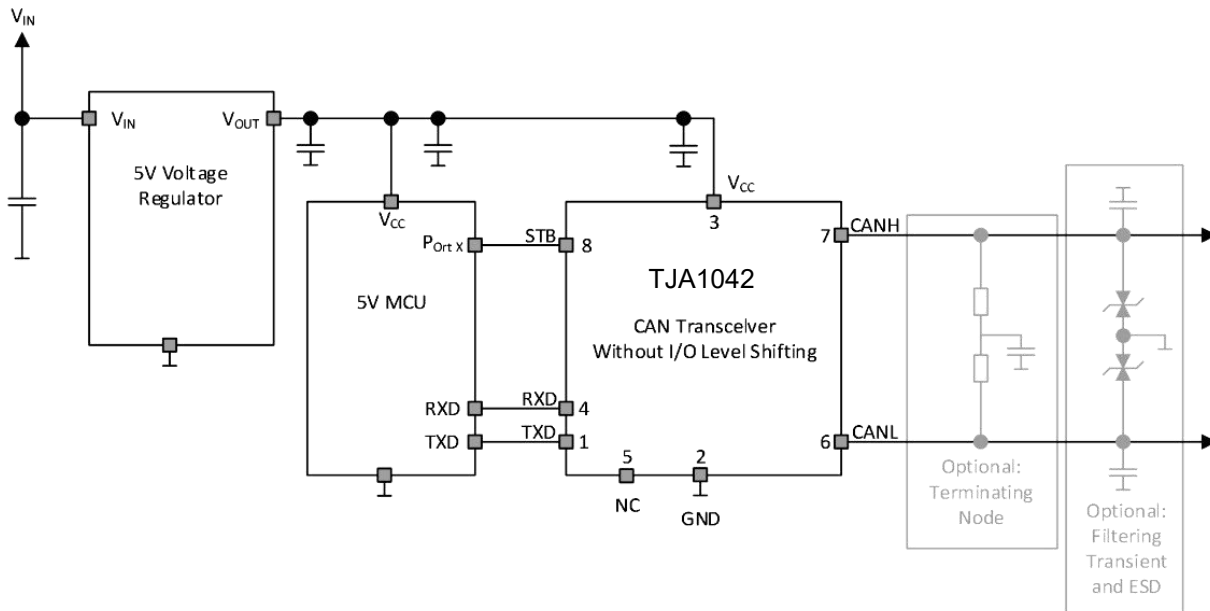

Figure 8-3. Typical CAN Bus Application Using 5V CAN Controller

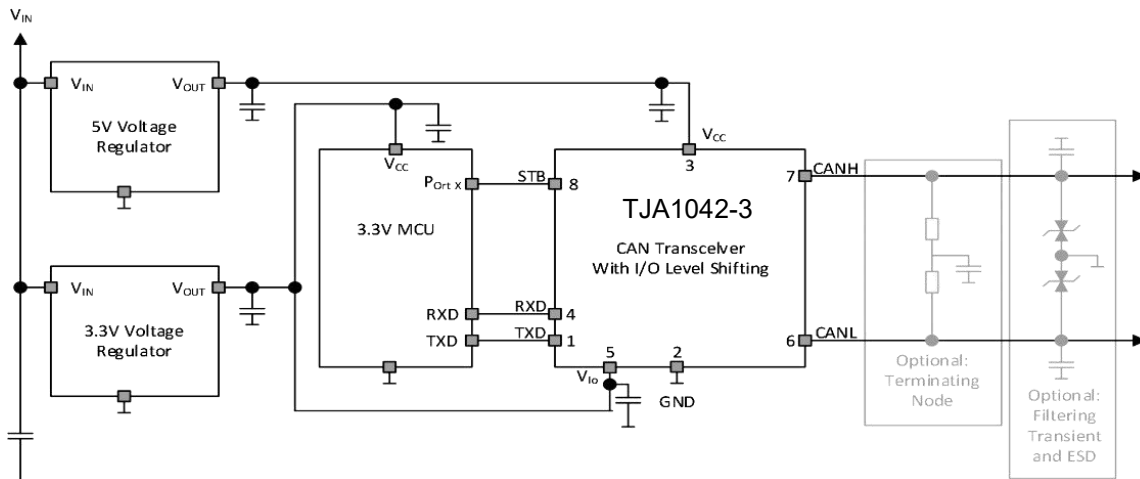

Figure 8-4. Typical CAN Bus Application Using 3.3V CAN Controller

9. Power Supply Recommendations

These devices are designed to operate from a V_{CC} input supply voltage range between 4.5V and 5.5V. Some devices have an output level shifting supply input, V_{IO} , designed for a range between 3V and 5.5V. Both supply inputs must be well regulated. A bulk capacitance, typically 4.7 μ F, should be placed near the CAN transceiver's main V_{CC} supply output, and in addition a bypass capacitor, typically 0.1 μ F, should be placed as close to the device V_{CC} and V_{IO} supply terminals. This helps to reduce supply voltage ripple present on the outputs of the switched-mode power supplies and also helps to compensate for the resistance and inductance of the PCB power planes and traces.

10. Layout

Robust and reliable bus node design often requires the use of external transient protection device in order to protect against EFT and surge transients that may occur in industrial environments. Because ESD and transients have a wide frequency bandwidth from approximately 3 MHz to 3 GHz, high-frequency layout techniques must be applied during PCB design. The family comes with high on-chip IEC ESD protection, but if higher levels of system level immunity are desired external TVS diodes can be used. TVS diodes and bus filtering capacitors should be placed as close to the on-board connectors as possible to prevent noisy transient events from propagating further into the PCB and system.

Layout Guidelines

- Place the protection and filtering circuitry as close to the bus connector, J1, to prevent transients, ESD and noise from propagating onto the board. In this layout example a transient voltage suppression (TVS) device, D1, has been used for added protection. The production solution can be either bi-directional TVS diode or varistor with ratings matching the application requirements. This example also shows optional bus filter capacitors C4 and C5. Additionally (not shown) a series common mode choke (CMC) can be placed on the CANH and CANL lines between the transceiver U1 and connector J1.
- Design the bus protection components in the direction of the signal path. Do not force the transient current to divert from the signal path to reach the protection device.
- Use supply (V_{CC}) and ground planes to provide low inductance.
- Use at least two vias for supply (V_{CC}) and ground connections of bypass capacitors and protection devices to minimize trace and via inductance.
- Bypass and bulk capacitors should be placed as close as possible to the supply terminals of transceiver,

examples are C1, C2 on the V_{CC} supply and C6 and C7 on the V_{IO} supply.

- Bus termination: this layout example shows split termination. This is where the termination is split into two resistors, R6 and R7, with the center or split tap of the termination connected to ground via capacitor C3. Split termination provides common mode filtering for the bus. When bus termination is placed on the board instead of directly on the bus, additional care must be taken to ensure the terminating node is not removed from the bus thus also removing the termination. See the application section for information on power ratings needed for the termination resistor(s).
- To limit current of digital lines, serial resistors may be used. Examples are R2, R3, and R4. These are not required.
- Terminal 1: R1 is shown optionally for the TXD input of the device. If an open drain host processor is used, this is mandatory to ensure the bit timing into the device is met.
- Terminal 5: For devices in this series with V_{IO} ports, bypass capacitors should be placed as close to the pin as possible (example C6 and C7). For device options without V_{IO} I/O level shifting, this pin is not internally connected and can be left floating or tied to any existing net, for example a split pin connection.
- Terminal 8: is shown assuming the mode terminal, STB, will be used. If the device will only be used in normal mode, R4 is not needed and R5 could be used for the pull down resistor to GND.

Layout Example

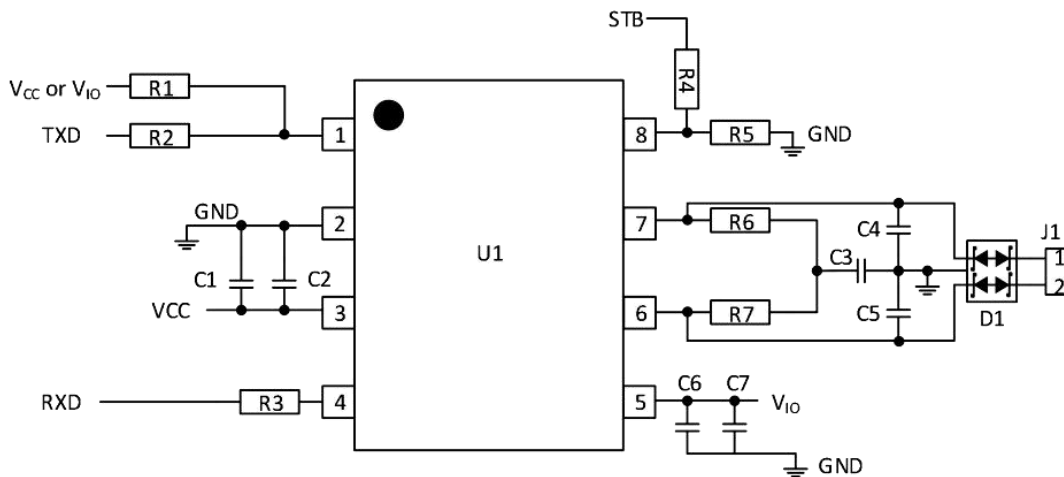
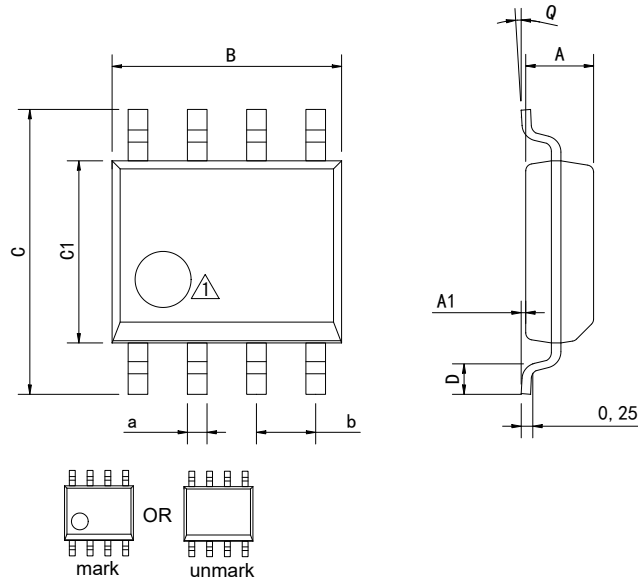

Figure 10-1. Layout Example

Physical Dimensions

SOP-8



△ Package top mark may be in lower left corner or unmark

Dimensions In Millimeters(SOP-8)									
Symbol:	A	A1	B	C	C1	D	Q	a	b
Min:	1.35	0.05	4.90	5.80	3.80	0.40	0°	0.35	1.27 BSC
Max:	1.55	0.20	5.10	6.20	4.00	0.80	8°	0.45	

DFN-8 3*3

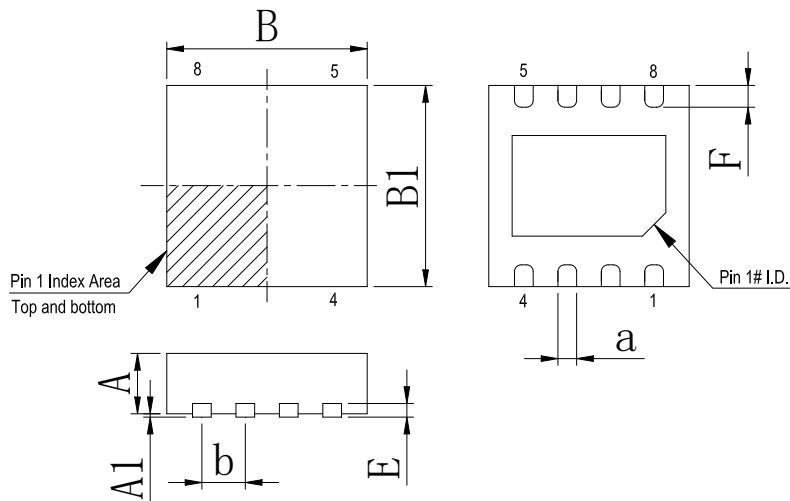

Dimensions In Millimeters(DFN-8 3*3)								
Symbol:	A	A1	B	B1	E	F	a	b
Min:	0.85	0.00	2.90	2.90	0.20	0.30	0.20	0.65 BSC
Max:	0.95	0.05	3.10	3.10	0.25	0.50	0.34	

Physical Dimensions

MSOP-8

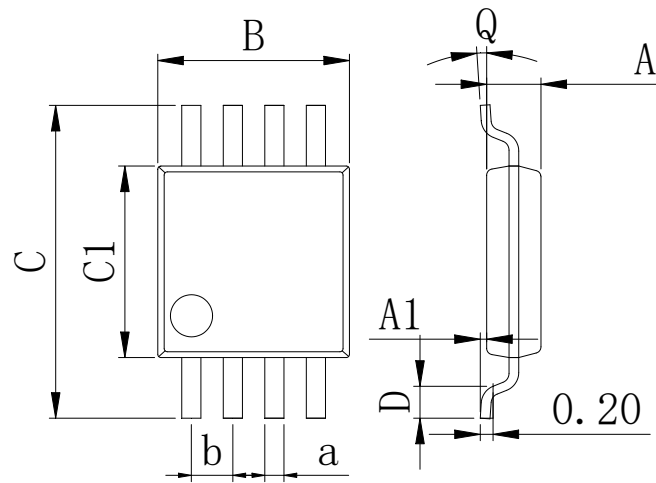

Dimensions In Millimeters(MSOP-8)									
Symbol:	A	A1	B	C	C1	D	Q	a	b
Min:	0.80	0.05	2.90	4.75	2.90	0.35	0°	0.25	0.65 BSC
Max:	0.90	0.20	3.10	5.05	3.10	0.75	8°	0.35	

Revision History

REVISION NUMBER	DATE	REVISION	PAGE
V1.0	2019-12	New	1-21
V1.1	2025-10	Document Reformatting	1-22

IMPORTANT STATEMENT:

Huaguan Semiconductor reserves the right to change products and services offered without prior notice. Customers should obtain the latest relevant information before placing orders and verify that such information is current and complete. Huaguan Semiconductor assumes no responsibility or liability for altered documents.

Customers are responsible for complying with safety standards and implementing safety measures when using Huaguan Semiconductor products in system design and end-product manufacturing. You assume full responsibility for: selecting the appropriate Huaguan Semiconductor products for your application; designing, validating, and testing your application; and ensuring that your application complies with applicable standards and all other safety, security, or other requirements. This is to prevent potential risks that may lead to personal injury or property damage.

Huaguan Semiconductor products are not approved for use in life support, military, aerospace, or other high-risk applications. Huaguan products are neither intended nor warranted for use in such systems or equipment. Any failure or malfunction may lead to personal injury or severe property damage. Such applications are deemed "Unsafe Use." Unsafe Use includes, but is not limited to: surgical and medical equipment, nuclear energy control equipment, aircraft or spacecraft instruments, control or operation of vehicle power, braking, or safety systems, traffic signal instruments, all types of safety devices, and any other applications intended to support or sustain life. Huaguan Semiconductor shall not be liable for consequences resulting from Unsafe Use in these fields. Users must independently evaluate and assume all risks. Any issues, liabilities, or losses arising from the use of products beyond their approved applications shall be solely borne by the user. Users may not claim any compensation from Huaguan Semiconductor based on these terms. If any third party claims against Huaguan Semiconductor due to such Unsafe Use, the user shall compensate Huaguan Semiconductor for all resulting damages and liabilities.

Huaguan Semiconductor provides technical and reliability data (including datasheets), design resources (including reference designs), application or other design advice, web tools, safety information, and other resources for its semiconductor products. However, no guarantee is made that these resources are free from defects, and no express or implied warranties are provided. The use of testing and other quality control techniques is limited to Huaguan Semiconductor's quality assurance scope. Not all parameters of each device are tested.

Huaguan Semiconductor's documentation authorizes you to use these resources only for developing applications related to the products described herein. You are not granted rights to any other intellectual property of Huaguan Semiconductor or any third party. Any other reproduction or display of these resources is strictly prohibited. You shall fully indemnify Huaguan Semiconductor and its agents against any claims, damages, costs, losses, and liabilities arising from your use of these resources. Huaguan Semiconductor shall not be held responsible.