



钜地半导体  
Tudi Semiconductor

## Product Specification

TUDI-TC4421/4422

9A High-Speed MOSFET Drivers

网址 [www.sztdbdt.com](http://www.sztdbdt.com) 🔍

**用芯智造 · 卓越品质**

**semiconductor device  
manufacturer**

- Design
- research and development
- production
- and sales



## Features

- Industry-standard pinout with additional enable features
- $\pm 9A$  high peak current drive capability using TrueDrive in the flat region
- Efficient constant current source implemented with a unique bipolar and CMOS output stage
- TTL/CMOS compatible inputs that are independent of the voltage
- Typical rise and fall times of 20ns with 10nF load
- Typical propagation delays of 25ns and 5ns for input fall and rise, respectively
- 4.5V to 18V supply voltage
- Thermally enhanced MSOP PowerPAD™ with  $4.7^{\circ}C/W$   $j_c$
- Rated for  $-40^{\circ}C$  to  $105^{\circ}C$
- Lead- surface finish (CU NIPDAU) on 8-pin SOIC and PDIP packages

## Explanation

The TC4421A/TC4422A are high-current buffer/drivers capable of driving large MOSFETs and Insulated Gate Bipolar Transistors (IGBTs). The TC4421A/TC4422A have matched output rise and fall times, as well as matched leading and falling-edge propagation delay times. The TC4421A/TC4422A devices also have very low cross-conduction current, reducing the overall power dissipation of the device.

These devices are essentially immune to any form of upset, except direct overvoltage or over-dissipation. They cannot be latched under any conditions within their power and voltage ratings. These parts are not subject to damage or improper operation when up to 5V of ground bounce is present on their ground terminals. They can accept, without damage or logic upset, more than 1A inductive current of either polarity being forced back into their outputs. In addition, all terminals are fully protected against up to 4 kV of electrostatic discharge. The TC4421A/TC4422A inputs may be driven directly from either TTL or CMOS (3V to 18V). In addition, 300 mV of hysteresis is built into the input, providing noise immunity and allowing the device to be driven from slowly rising or falling waveforms. With both surface-mount and pin-through-hole packages, in addition to a wide operating temperature range, the TC4421A/TC4422A family of 9A MOSFET drivers fit into most any application where high gate/line capacitance drive is required.

## Application

- Line Drivers for Extra Heavily-Loaded Lines
- Pulse Generators
- Driving the Largest MOSFETs and IGBTs
- Local Power ON/OFF Switch
- Motor and Solenoid Driver
- LF Initiator

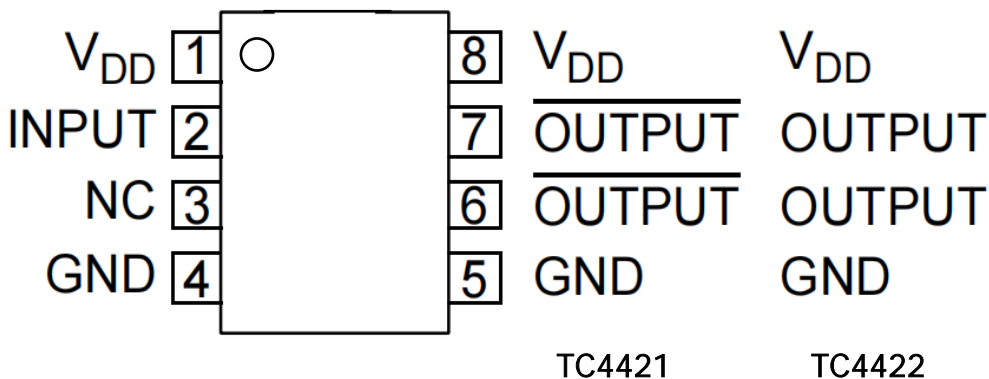

Figure 1. Pin Diagram

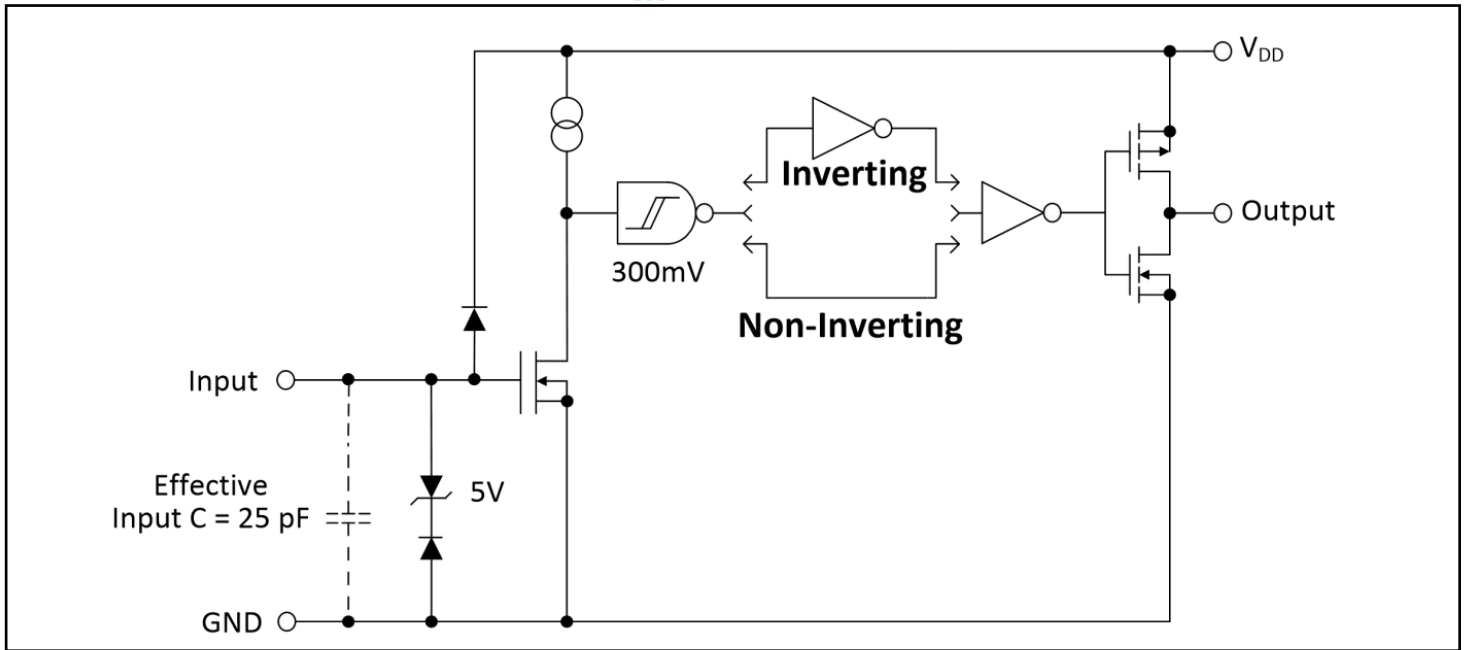

Figure 2. Functional Block Diagram

4421: Output out of phase with input

4422: Output in phase with input

## Pin Description

Pin	Name	Description
1	VDD	Power Supply
2	INPUT	Control input,TTL/CMOS compatible input
3	NC	No Connection
4	AGND	Ground
5	PGND	Ground
6	OUTPUT	CMOS push-pull output
7	OUTPUT	CMOS push-pull output
8	VDD	Power Supply
	PAD	Exposed Metal Pad,electrically isolated

Note: Duplicate pins must both be connected for proper operation.



## Product Specification

Absolute Maximum Ratings(1)			
Parameter	Min	Max	Unit
DC supply voltage Vs		28	V
Operating junction temperature	-40	+125	°C
Storage temperature	-55	+150	°C
Maximum input voltage	GND-5	VDD+0.3	V
Thermal Data			
Parameter	Rating		Unit
Package Thermal Resistance	155(SOP8) 125(DIP8)		°C/W
Recommended Operating Conditions			
Parameter	Rating		Unit
DC Supply Voltage	4.5V~25V		V
Operating ambient temperature	-40 to +125		°C

Parameter	Symbol	Conditions	Min.	Typ.	Max.	Unit
INPUT						
Input Signal High Threshold	VIH		1.6			V
Input Signal Low Threshold	VIL				0.7	V
Input Signal Hysteresis	VHYS			0.3		V
Input Signal High Current	IH	Inverting Input Current, VINx=18V			0.01	μA
		Non-inverting Input Current, VINx=18V		88	125	
Input Signal High Current	IL	Inverting Input Current, VINx=0V		88	125	μA
		Non-inverting Input Current, VINx=0V			0.01	



Parameter	Symbol	Conditions	Min.	Typ.	Max.	Unit
OUTPUT						
High Output Voltage VOH	VoH	DC Test	VDD- 0.025			V
Low Output Voltage	VoL	DC Test			0.025	V
Pull-Up Resistance	RoH	Source Current =10mA		0.83		Ω
Pull-Down Resistance	RoL	Sink Current = -10mA		0.5		Ω
Peak Output Current	I <sub>pK</sub>	10V ≤ VDD ≤ 18V		9.0		A
POWER SUPPLY						
Power Supply Current	I <sub>cc</sub>	V <sub>IN</sub> =3V		0.85		mA
		V <sub>IN</sub> =0V		0.65		
Operating Voltage Range	VDD		4.5		25	V
Under-Voltage Lockout ON Threshold				3.7	4.1	V
Under-Voltage Lockout Hysteresis				0.5		V
SWITCHING CHARACTERISTICS						
Rise Time	t <sub>R</sub>	CL=10,000 pF, See Figure 3		35		ns
Fall Time	t <sub>F</sub>	CL=10,000 pF, See Figure 3		36		ns
Turn-On Delay Time	t <sub>D1</sub>	4421,C=10,000pF 4422,		58		ns
		C=10,000pF 4421,C=10		60		ns
Turn-Off Delay Time	t <sub>D2</sub>	,000pF 4422,C=10,		59		ns
		000pF		63		ns
OVER-TEMPERATURE PROTECTION						
Thermal Shutdown				150		°C
Thermal Shutdown Threshold				25		°C

Stresses exceeding the absolute maximum ratings may damage the device. The device may not function or be operable above the recommended operating conditions and stressing the parts to these levels is not recommended. In addition, extended exposure to stresses above the recommended operating conditions may affect device reliability. The absolute maximum ratings are stress ratings only.



<b>Input</b>
MOSFET driver input is a high-impedance,TTL/CMOS compatible input.It also has 300 mV of hysteresis between the high and low thresholds that prevents output glitching even when the rise and fall time of the input signal is very slow.
<b>Ground (GND)</b>
Ground is the device return pin.The Ground pin(s)should have a low-impedance connection to the bias supply source return.High peak current flows out the Ground pin(s)when the capacitive load is being discharged.
<b>Output</b>
MOSFET driver outputs are low-impedance,CMOS push-pull style outputs.The pull-down and pullup devices are of equal strength,making the rise and fall times equivalent.The Output is held LOW if Input is unbiased or floating.
<b>Supply Input (VDD)</b>
The VDD input is the bias supply for the MOSFET driver and is rated for 4.5V to 25V with respect to the Ground pin.The VDD input should be bypassed with local ceramic capacitors.The value of these capacitors should be chosen based on the capacitive load that is being driven.A value of 1.0 $\mu$ F is suggested.
<b>Exposed Metal Pad</b>
The exposed metal pad of the DFN-S package is not internally connected to any potential.Therefore,this pad can be connected to a ground plane or other copper plane on a Printed Circuit Board(PCB),to aid in heat removal from the package.



## Application Information

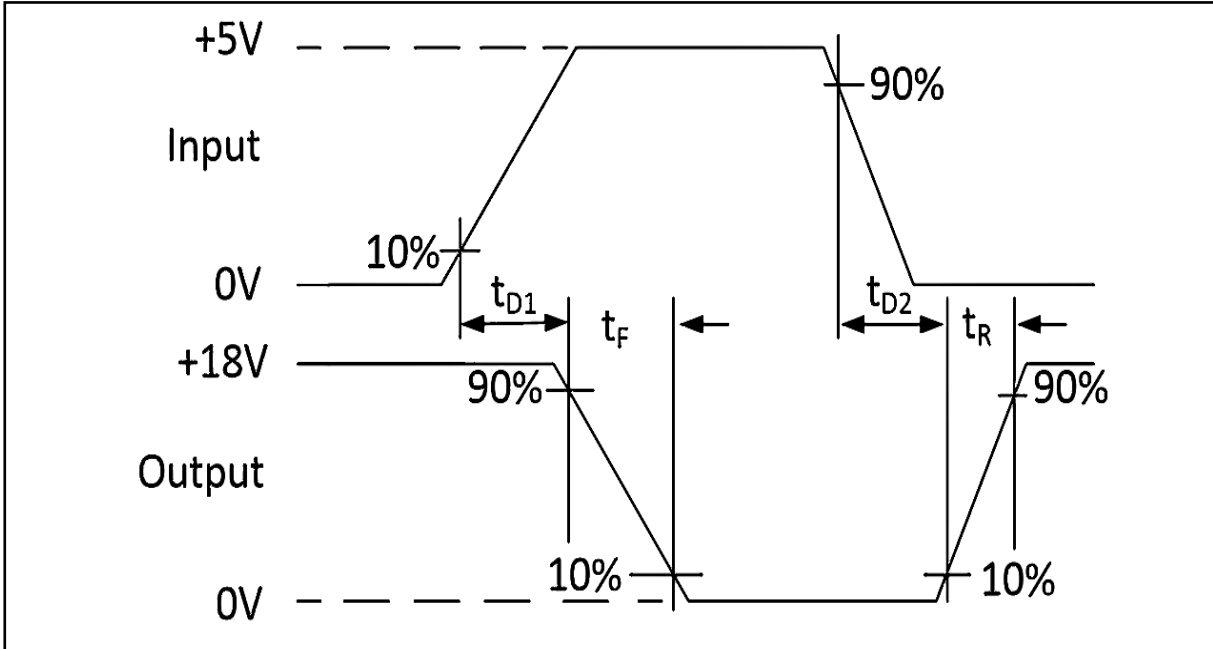

Inverting Driver

4421

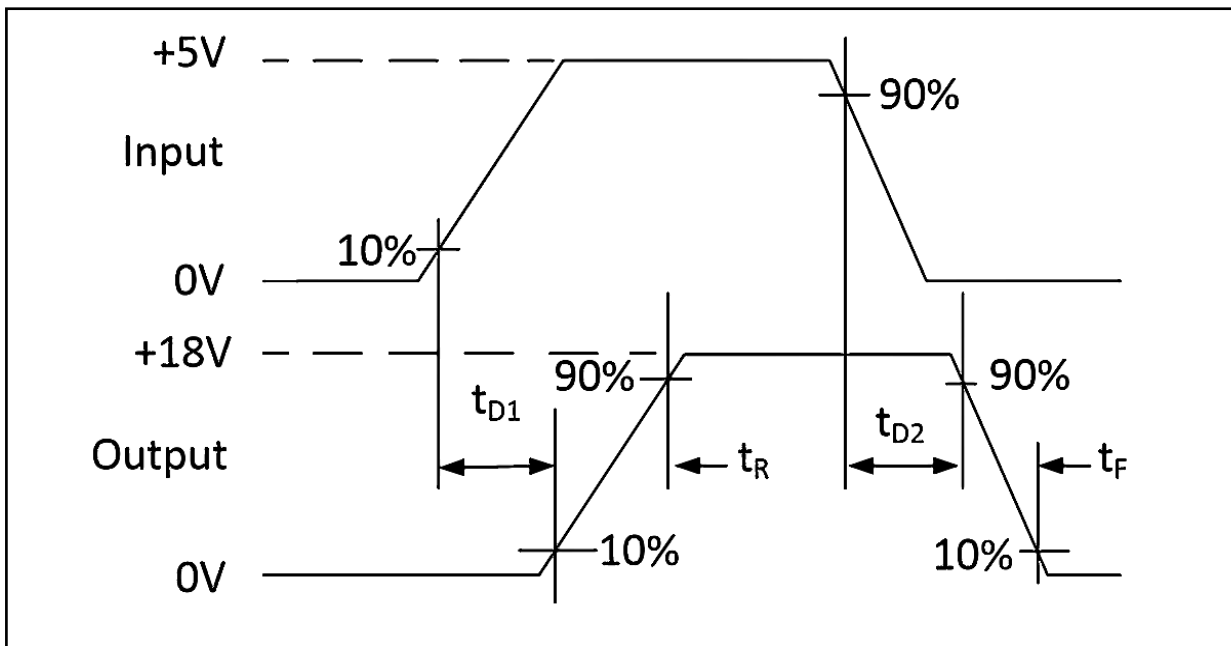

Non-Inverting Driver

4422

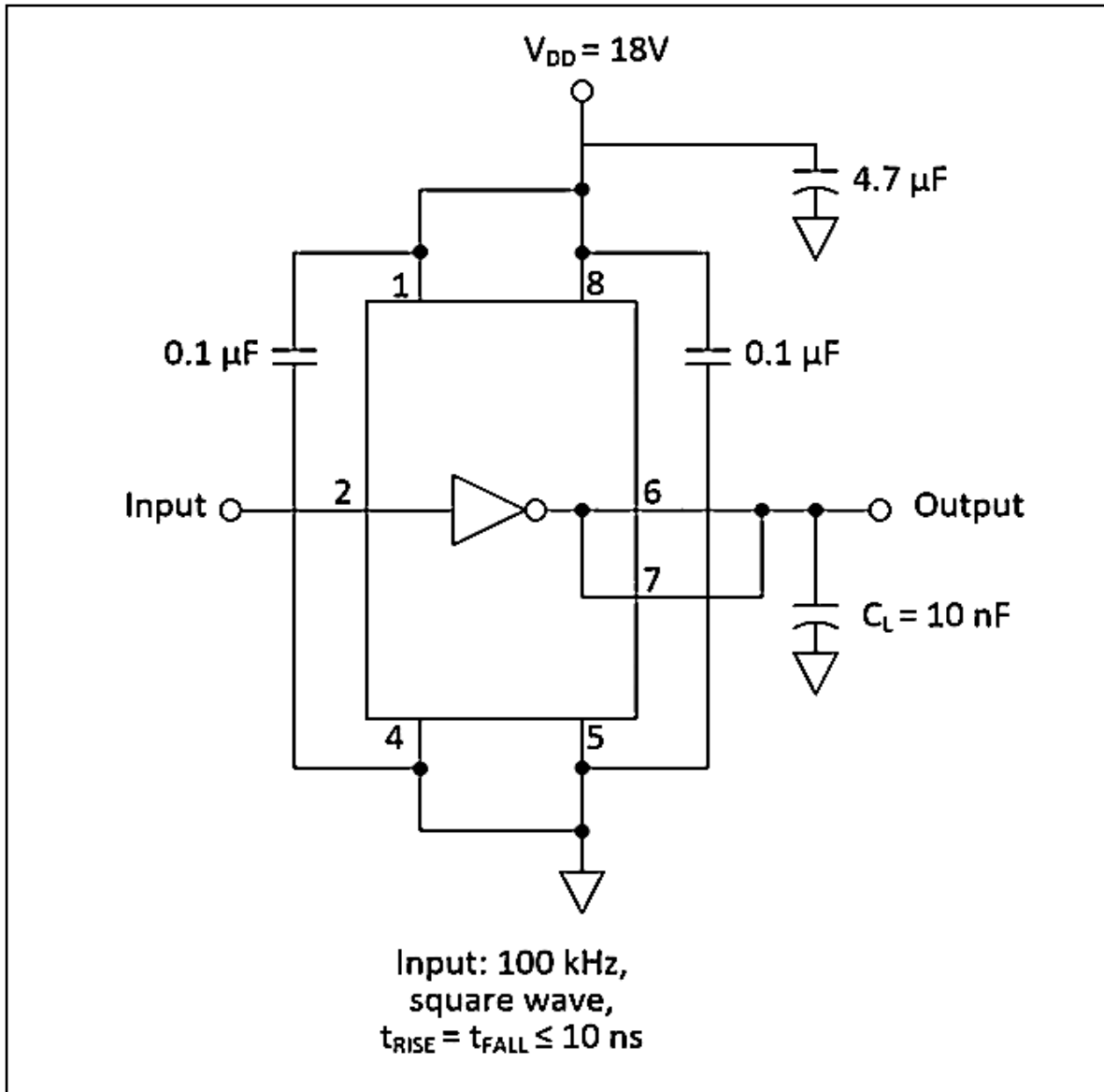

Figure 3. Switching Time Test Circuit



## Order information

Order Number	Package	Package Quantity	Marking On The park	Temperature
TC4421AVOA713-TUDI	SOP8	Tape,Reel,2500	TC4421AVOA	- 40°C to 125°C
TC4421AVPA-TUDI	DIP8	Tube,50,A box of 2000	TC4421AVPA	
TC4422AVOA713-TUDI	SOP8	Tape,Reel,2500	TC4422AVOA	
TC4422AVPA-TUDI	DIP8	Tube,50,A box of 2000	TC4422AVPA	



Package SOP8

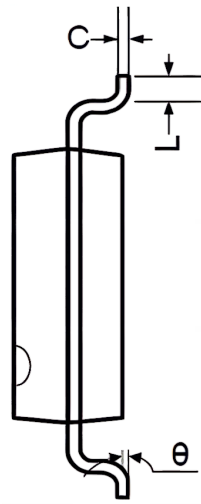
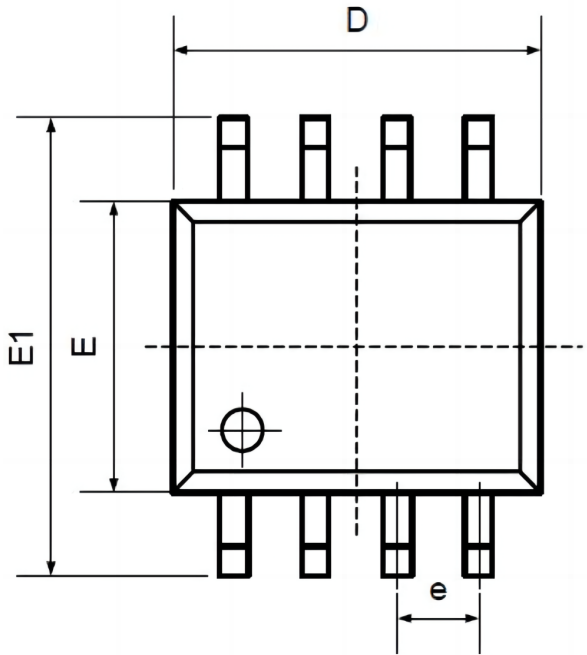

Symbol	Dimensions In Millimeters		Dimensions In Inches	
	Min	Max	Min	Max
A	1.350	1.750	0.053	0.069
A1	0.100	0.250	0.004	0.010
A2	1.350	1.550	0.053	0.061
B	0.330	0.510	0.013	0.020
C	0.190	0.250	0.007	0.010
D	4.780	5.000	0.188	0.197
E	3.800	4.000	0.150	0.157
E1	5.800	6.300	0.228	0.248
e	1.270TYP		0.050TYP	
L	0.400	1.270	0.016	0.050
theta	0°	8°	0°	8°

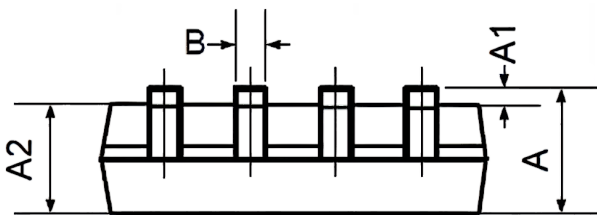



Package DIP8

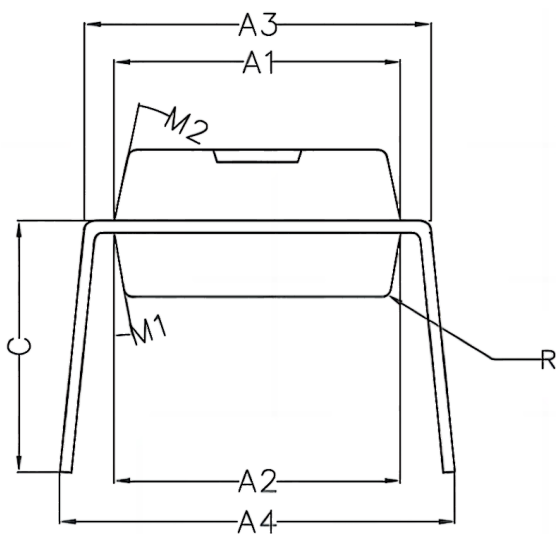
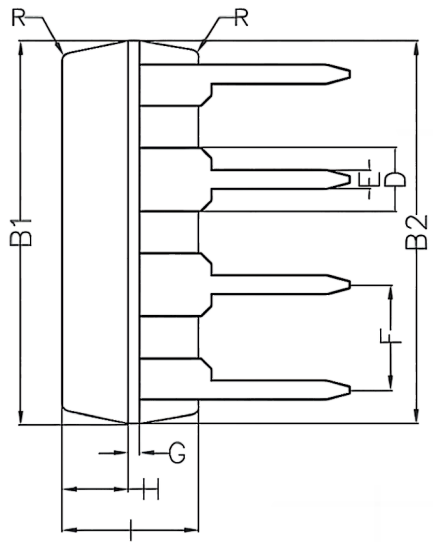
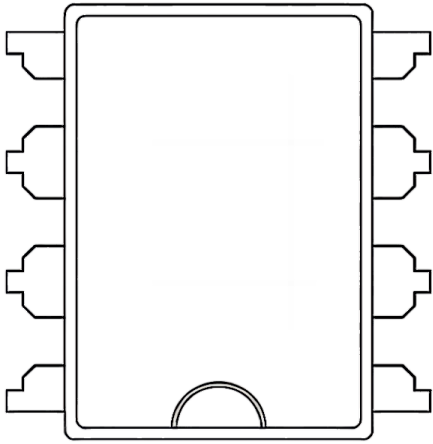

Symbol	Min	Non	Max
A1	6.28	6.33	6.38
A2	6.33	6.38	6.43
A3	7.52	7.62	7.72
A4	7.80	8.40	9.00
B1	9.15	9.20	9.25
B2	9.20	9.25	9.30
C		5.57	
D		1.52	
E	0.43	0.45	0.47
F		2.54	
G		0.25	
H	1.54	1.59	1.64
I	3.22	3.27	3.32
R		0.20	
M1	9°	10°	11°
M2	11°	12°	13°



## Important statement:

- TUDI Semiconductor reserves the right to modify the product manual without prior notice! Before placing an order, customers need to confirm whether the obtained information is the latest version and verify the completeness of the relevant information.
- Any semi-guide product is subject to failure or malfunction under specified conditions. It is the buyer's responsibility to comply with safety standards when using TUDI Semiconductor products for system design and whole machine manufacturing. And take the appropriate safety measures to avoid the potential in the risk of loss of personal injury or loss of property situation!
- TUDI Semiconductor products have not been licensed for life support, military, and aerospace applications, and therefore TUDI Semiconductor is not responsible for any consequences arising from the use of this product in these areas.
- If any or all TUDI Semiconductor products (including technical data, services) described or contained in this document are subject to any applicable local export control laws and regulations, they may not be exported without an export license from the relevant authorities in accordance with such laws.
- The specifications of any and all TUDI Semiconductor products described or contained in this document specify the performance, characteristics, and functionality of said products in their standalone state, but do not guarantee the performance, characteristics, and functionality of said products installed in Customer's products or equipment. In order to verify symptoms and conditions that cannot be evaluated in a standalone device, the Customer should ultimately evaluate and test the device installed in the Customer's product device.
- TUDI Semiconductor documentation is only allowed to be copied without any alteration of the content and with the relevant authorization. TUDI Semiconductor assumes no responsibility or liability for altered documents.
- TUDI Semiconductor is committed to becoming the preferred semiconductor brand for customers, and TUDI Semiconductor will strive to provide customers with better performance and better quality products.