

REV. (版本号)	DESCRIPTION (变更说明)	DATE (日期)	APPD (核准)
A0	新订图面	2022. 10. 26	ZHUANG

- Specifications:
- Electrical performance:
    - Contact resistance: 40mΩ max for initial, 10mΩ change after test. measure at 20mv, 100mA.
    - Dielectric withstanding voltage: AC 100V(rms).
    - Insulation resistance: 100MΩ min.
    - Contact current rating: 3A for Vbus pin; 4.25A for Vconn and GND pin; 0.25A for all the other pin.
    - Voltage: 20 Vac (rms).
  - mechanical performance:
    - Mating force: 5~20N
    - Unmating force: 8~20N Initial test, 6~20N After test
    - Durability: 10,000 cycles.
  - Environmental performance:
    - Temperature range:
      - Operating temperature: -40°to+85°.
      - Storage temperature: -20°to+60°.
  - Material:
    - Housing: LCP E130I Black, UL94-V0.
    - Contact: C18400, T=0.15mm
    - Mid-plate: SUS301, T=0.15mm
    - Shell: SUS304 T=0.30mm
    - Shell-EMI: SUS301 T=0.1
  - Plating specification:
    - Contact: Au (see table) plated on contact area Matte Tin plated 50u"min on solder area; Nickel 50u"min underplating over all.
    - Shell: 50u"min nickel plating.
    - Shell-EMI: None plating.

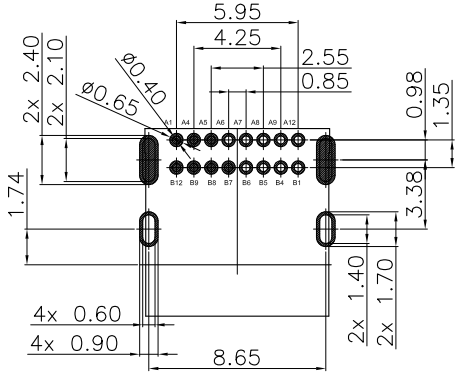

RECOMMENDED PCB LAYOUT(TOP)  
TOLERANCES: ±0.05MM

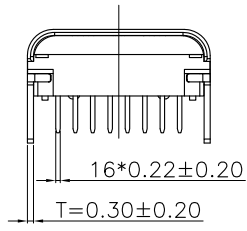

CCD 检测产品  
倾斜角度尺寸

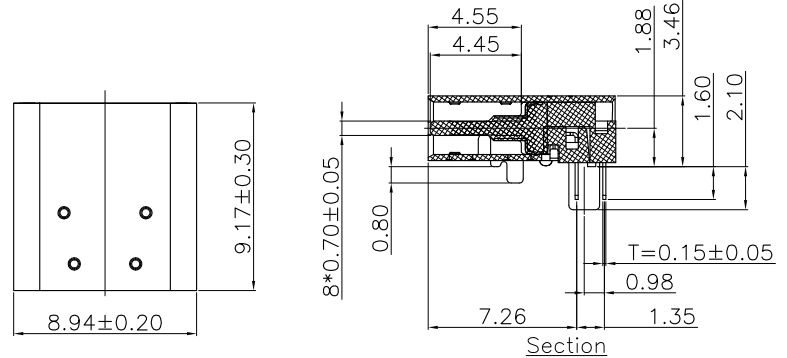

Section  
A-A

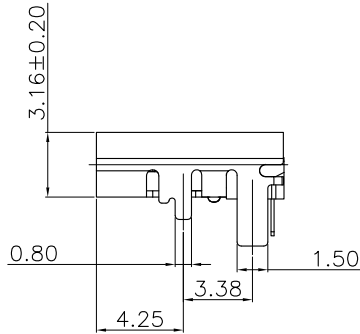

Section  
B-B

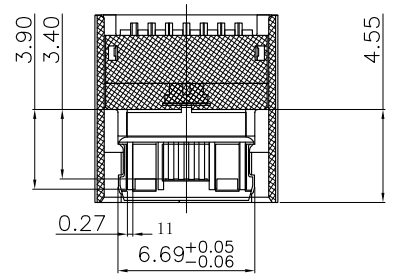
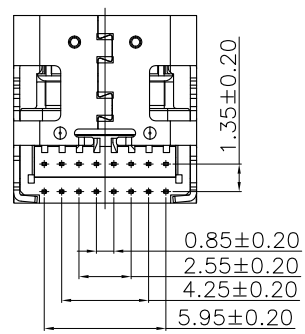
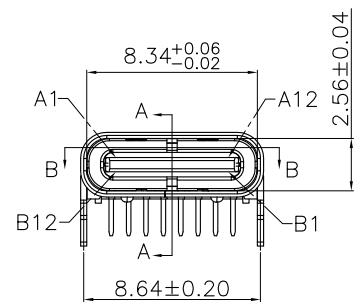

A1	GND	B12	GND
A2	N/A	B11	N/A
A3	N/A	B10	N/A
A4	VBUS	B9	VBUS
A5	CC1	B8	SBU2
A6	DP1	B7	DN2
A7	DN1	B6	DP2
A8	SBU1	B5	CC2
A9	VBUS	B4	VBUS
A10	N/A	B3	N/A
A11	N/A	B2	N/A
A12	GND	B1	GND
PIN	SIGNAL NAME	PIN	SIGNAL NAME

 深圳市宇文发电子科技有限公司  
Shen Zhen Yu Wen Fa Electronics Technology Co., Ltd  
TEL: 0755-27711235 FAX: 0755-27712683

品名 (ITEM NO)	TYPE C 16P母座 双排DIP 无LOGO款
料号 (PART NO)	PTCFW-H23A-002
图号 (DWG NO)	P-TCF-102

页码 (SHEET)	1/1	单位 (UNIT):	MM
版本 (REV)	A0	比例 (SCALE)	1:1
日期 (DATE)	2022. 10. 26	设计 (DESIGN)	ZHUANG
审核 (CHECKED)		核准 (APPROVED)	
		未注公差 TOLERANCE UNSPECIFIED	
		X.X	±0.30
		X.XX	±0.20
		X.XXX	±0.10
		X°	±5°
		X.X°	±2°

RoHS Compliant

REV.	ECN NO	DESCRIPTION	REVISER	DATE
A/0				
A/1				

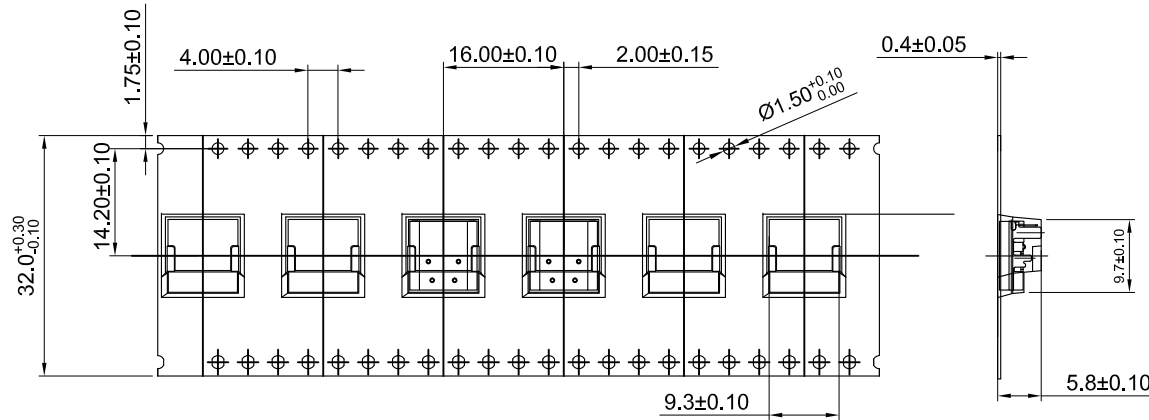
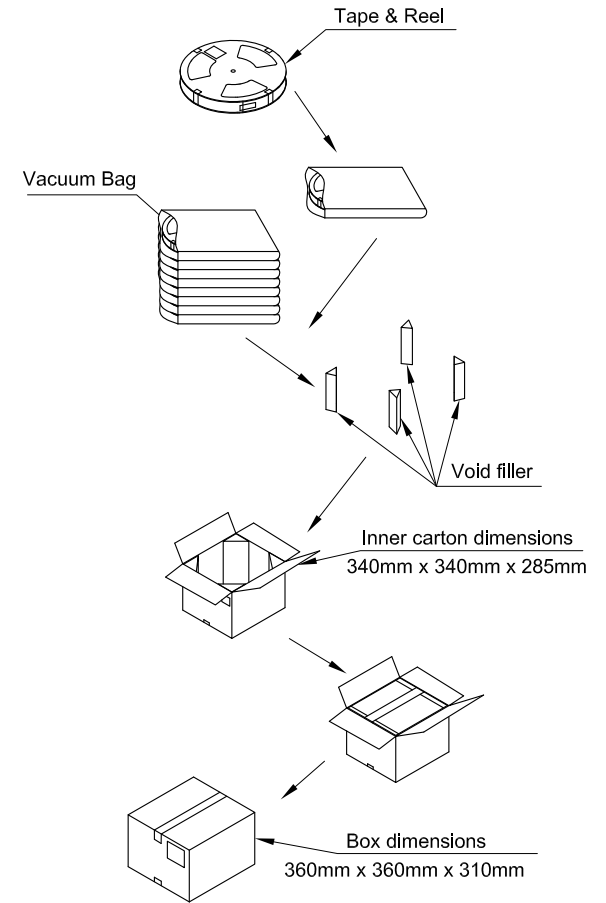
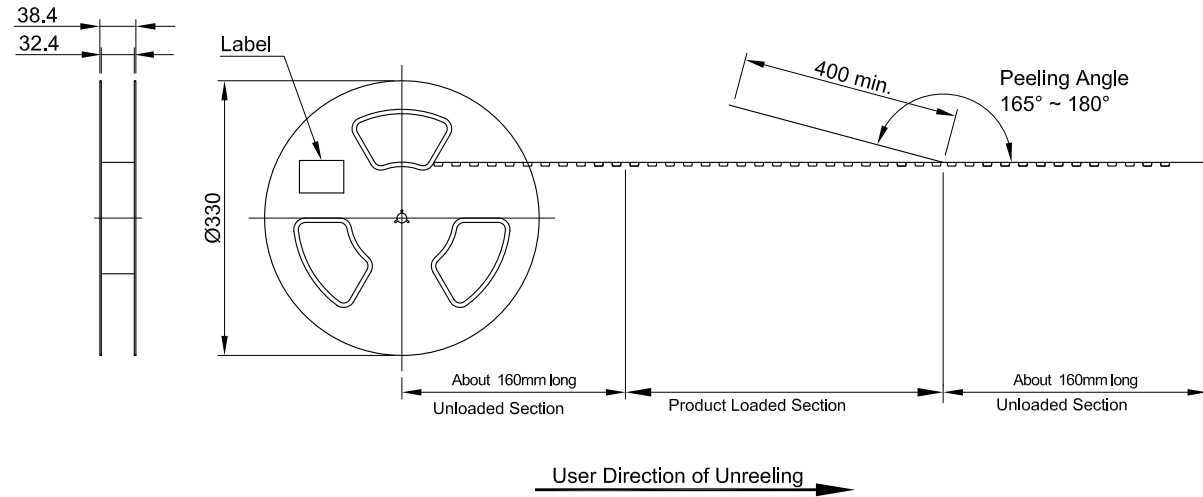

Notes:  
Peeling off force of top tape: 0.1-1.3N (Peeling direction as shown)

Materials:  
Carrier Tape: Polystyrene (PS)  
Top Tape: PE  
Reel Tape: Polystyrene (PS)  
Bag: PE

	REEL	CARTON
CONNECTOR (PCS)	700	4900

图号 (DWG NO)	单位 (UNIT): MM	深圳市宇文发电子科技有限公司 Shen Zhen Yu Wen Fa Electronics Technology Co.,Ltd TEL: 0755-27711235 FAX: 0755-27712683	
日期 (DATE)	2022. 11. 20		
版次 (REV): A/0	页/次(PAGE): 1/1		
设计 (DESIGN)	ZHUANG	包装规范	
审核 (CHECKED)			
核准 (APPROVED)		品名 (ITEM NO)	TYPE C 母座 16P 双排DIP 包装图
		料号 (PART NO)	A-004R-129