

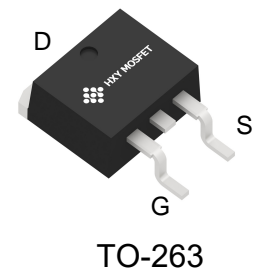

## Description

The 16N65 uses advanced trench technology to provide excellent  $R_{DS(ON)}$ , low gate charge and operation with gate voltages as low as 4.5V. This device is suitable for use as a Battery protection or in other Switching application.



## General Features

$V_{DS} = 650V$   $I_D = 16A$

$R_{DS(ON)} < 0.55\Omega @ V_{GS}=10V$

## Application

Battery protection

Load switch

Uninterruptible power supply

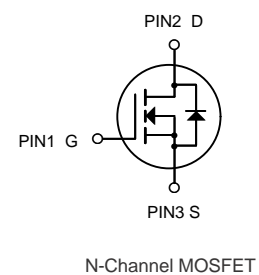

## Ordering Information

Product ID	Pack	Brand	Qty(PCS)
16N65	TO-263	HXY MOSFET	800

## Absolute Maximum Ratings

Symbol	Parameter	Limit	Units
$V_{DS}$	Drain-Source Voltage	650	V
$V_{GS}$	Gate-Source Voltage	$\pm 30$	V
$I_D$	Drain Current-Continuous	16	A
$I_{DM}$	Drain Current-Pulsed <sup>a</sup>	64	A
$P_D$	Maximum Power Dissipation @ $T_C = 25^\circ C$ - Derate above $25^\circ C$	180	W
		1.1	W/ $^\circ C$
$E_{AS}$	Single Pulsed Avalanche Energy <sup>d</sup>	1000	mJ
$I_{AS}$	Single Pulsed Avalanche Current <sup>d</sup>	64	A
$T_J, T_{stg}$	Operating and Store Temperature Range	-55 to 175	$^\circ C$
$R_{\theta JC}$	Thermal Resistance, Junction-to-Case	0.69	$^\circ C/W$
$R_{\theta JA}$	Thermal Resistance, Junction-to-Ambient	62.5	$^\circ C/W$



**Electrical Characteristics**  $T_C = 25^\circ\text{C}$  unless otherwise noted

Symbol	Parameter	Min.	Typ.	Max.	Unit	Test Conditions
$BV_{DSS}$	Drain-to-Source Breakdown Voltage	650	--	--	V	$V_{GS}=0V, I_D=250\mu A$
$I_{DSS}$	Drain-to-Source Leakage Current	--	--	1.0	$\mu A$	$V_{DS}=650V, V_{GS}=0V$
		--	--	100		$V_{DS}=520V, V_{GS}=0V,$ $T_J=125^\circ C$
$I_{GSS}$	Gate-to-Source Leakage Current	--	--	+100	$nA$	$V_{GS}=+30V, V_{DS}=0V$
		--	--	-100		$V_{GS}=-30V, V_{DS}=0V$
$R_{DS(ON)}$	Static Drain-to-Source On-Resistance <sup>[4]</sup>	--	0.45	0.55	$\Omega$	$V_{GS}=10V, I_D=8A$
$V_{GS(TH)}$	Gate Threshold Voltage	2.0	--	4.0	V	$V_{DS}=V_{GS}, I_D=250\mu A$
$g_{fs}$	Forward Transconductance <sup>[4]</sup>	--	15	--	S	$V_{DS}=15V, I_D=8A$
$C_{iss}$	Input Capacitance	--	2442	--	$pF$	$V_{GS}=0V,$ $V_{DS}=25V,$ $f=1.0MHz$
$C_{rss}$	Reverse Transfer Capacitance	--	18.5	--		
$C_{oss}$	Output Capacitance	--	218	--		
$Q_g$	Total Gate Charge	--	54	--	$nC$	$V_{DD}=325V,$ $I_D=16A, V_{GS}=0$ to 10V
$Q_{gs}$	Gate-to-Source Charge	--	12	--		
$Q_{gd}$	Gate-to-Drain (Miller) Charge	--	21	--		
$t_{d(ON)}$	Turn-on Delay Time	--	15	--	$nS$	$V_{DD}=325V,$ $I_D=16A,$ $V_{GS}=10V$ $R_G=6.1\ \Omega$
$t_{rise}$	Rise Time	--	52	--		
$t_{d(OFF)}$	Turn-Off Delay Time	--	59	--		
$t_{fall}$	Fall Time	--	72	--		
$I_{SD}$	Continuous Source Current <sup>[4]</sup>	--	--	16	A	Integral PN-diode in MOSFET
$I_{SM}$	Pulsed Source Current <sup>[4]</sup>	--	--	64		
$V_{SD}$	Diode Forward Voltage	--	--	1.5	V	$I_S=16A, V_{GS}=0V$
$t_{rr}$	Reverse recovery time	--	380	--	V	$V_{GS}=0V, I_F=16A,$ $di_F/dt=100A/\mu s$
$Q_{rr}$	Reverse recovery charge	--	2.6	--	$\mu C$	

**Note:**

[1]  $T_J=+25^\circ C$  to  $+150^\circ C$

[2] Repetitive rating; pulse width limited by maximum junction temperature.

[3]  $I_{SD}=16A, di/dt < 100 A/\mu s, V_{DD} < BV_{DSS}, T_J=+150^\circ C.$

[4] Pulse width  $\leq 380\mu s$ ; duty cycle  $\leq 2\%$ .



### Typical Characteristics

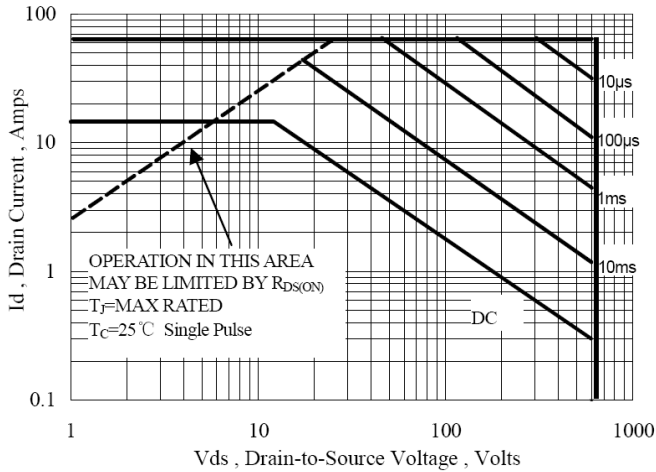

Figure 1 Maximum Forward Bias Safe Operating Area

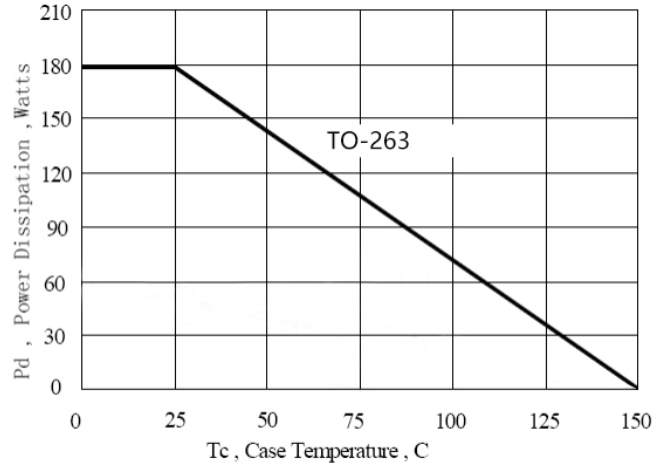

Figure 2 Maximum Power Dissipation vs Case Temperature

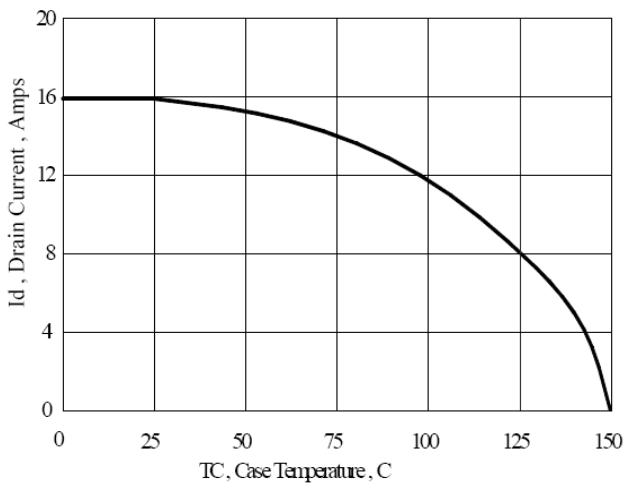

Figure 3 Maximum Continuous Drain Current vs Case Temperature

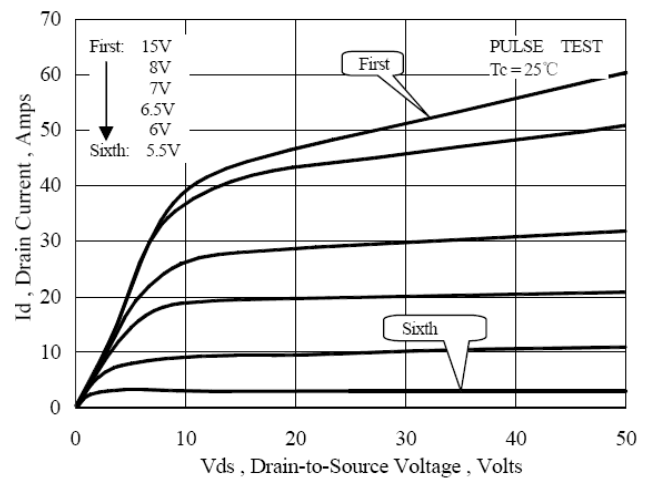

Figure 4 Typical Output Characteristics

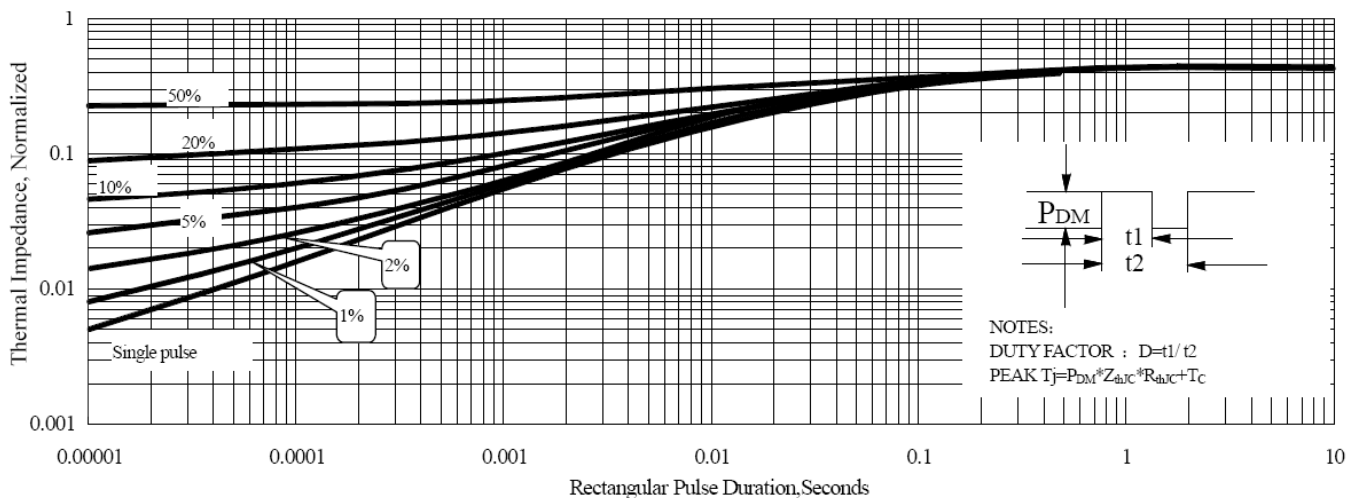
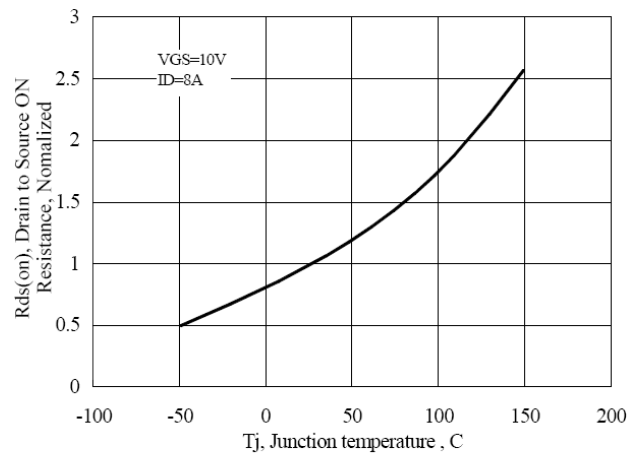
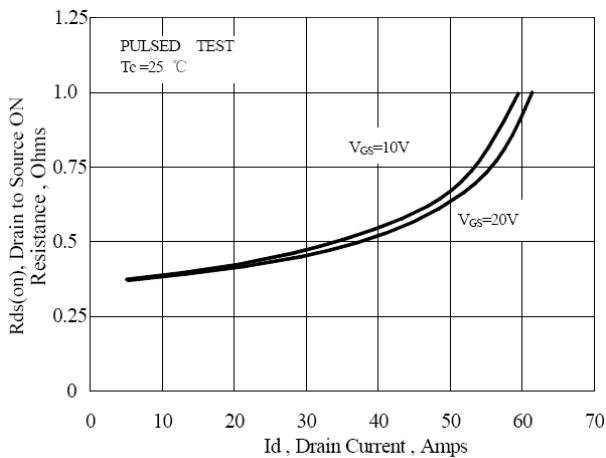
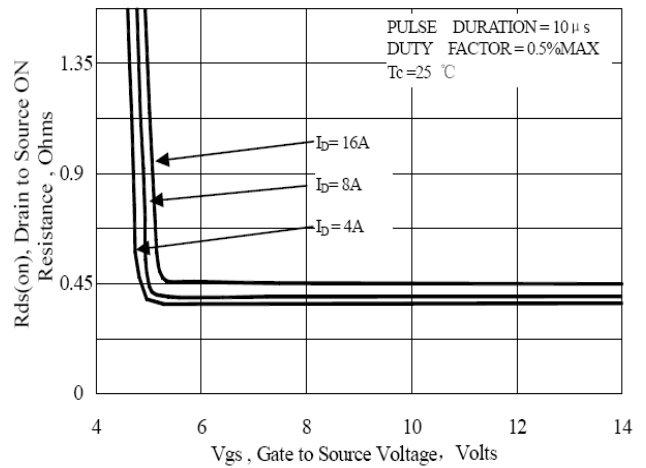
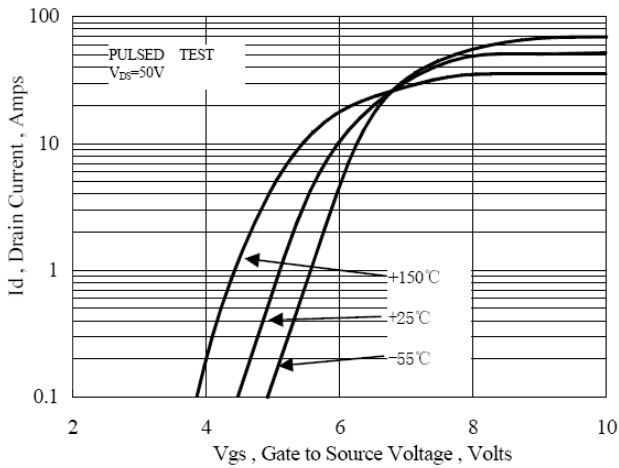
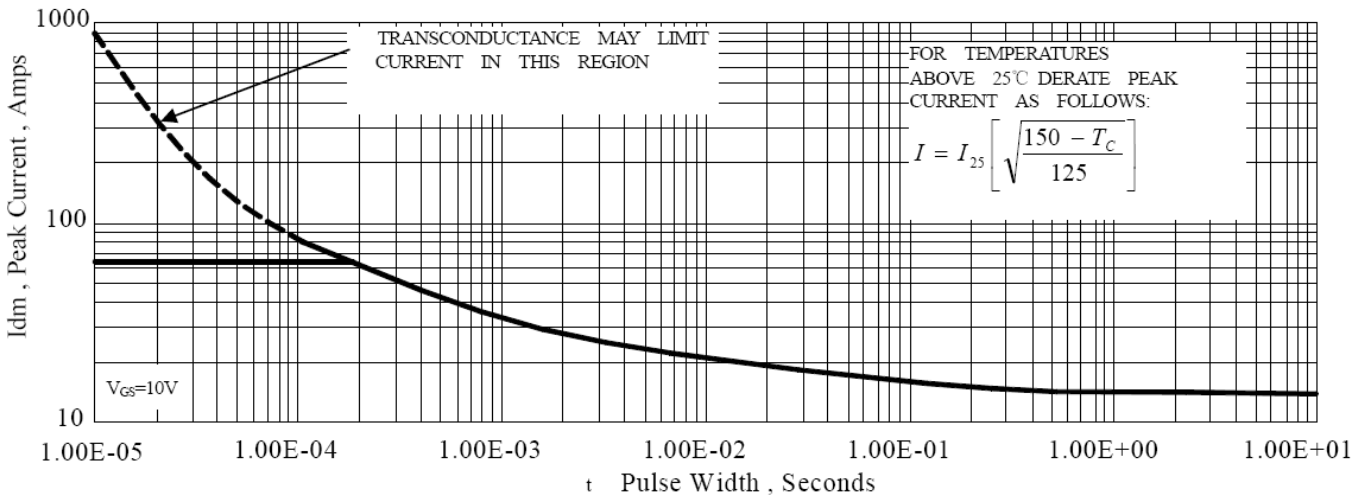

Figure 5 Maximum Effective Thermal Impedance, Junction to Case



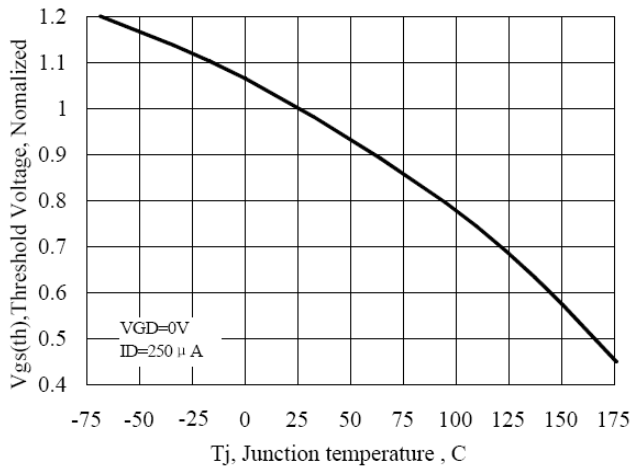

Figure 11 Typical Threshold Voltage vs Junction Temperature

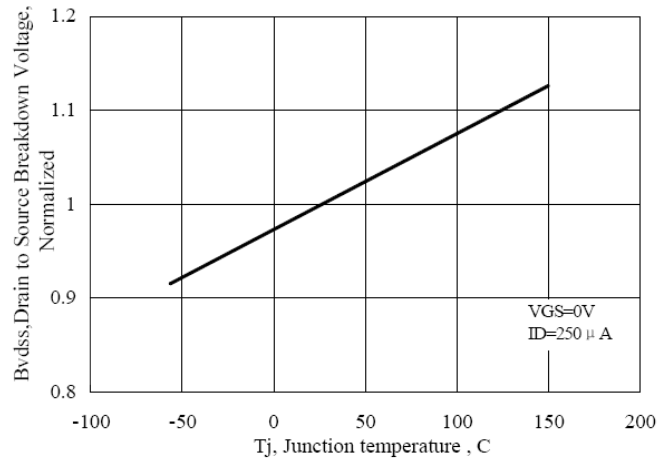

Figure 12 Typical Breakdown Voltage vs Junction Temperature

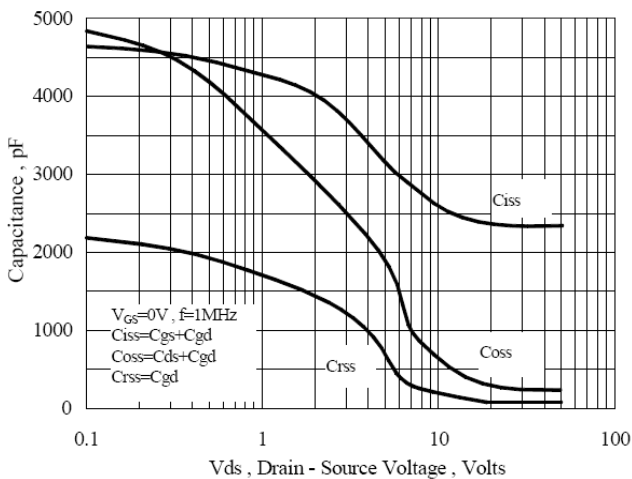

Figure 13 Typical Capacitance vs Drain to Source Voltage

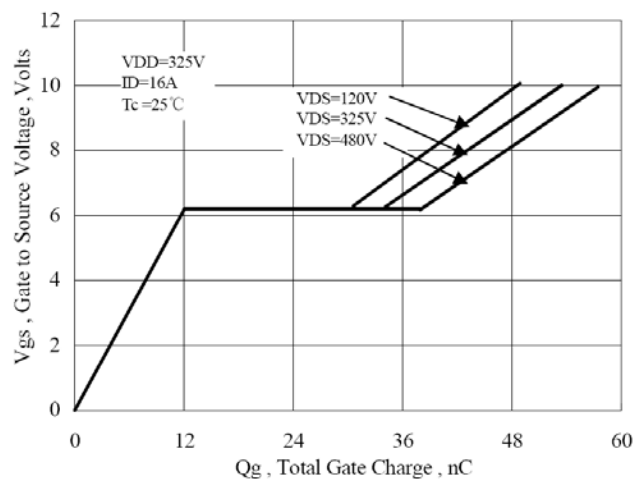

Figure 14 Typical Gate Charge vs Gate to Source Voltage

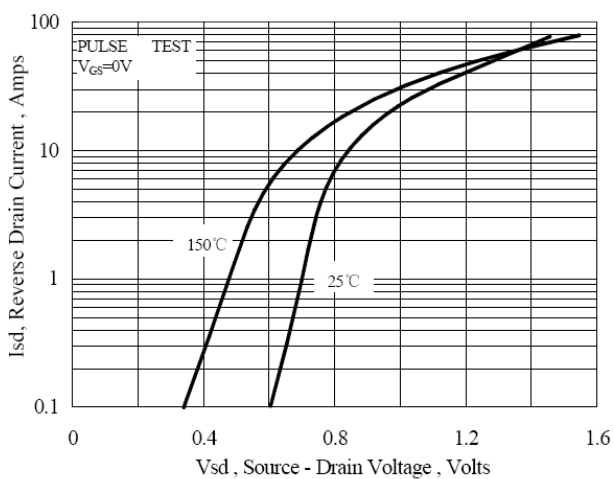

Figure 15 Typical Body Diode Transfer Characteristics

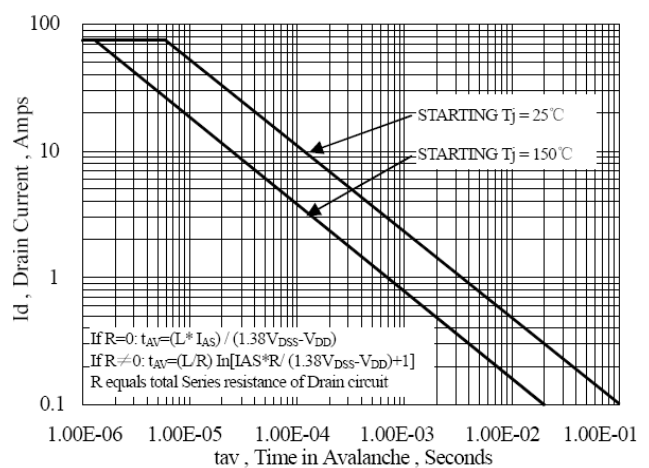

Figure 16 Unclamped Inductive Switching Capability



### Test Circuits and Waveforms

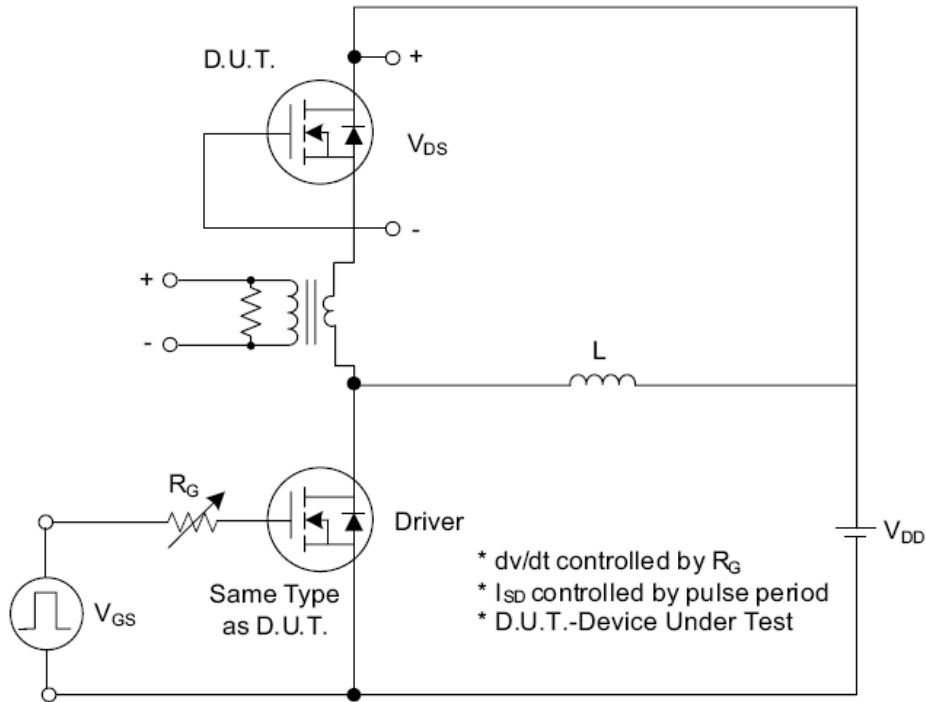

Fig. 1.1 Peak Diode Recovery  $dv/dt$  Test Circuit

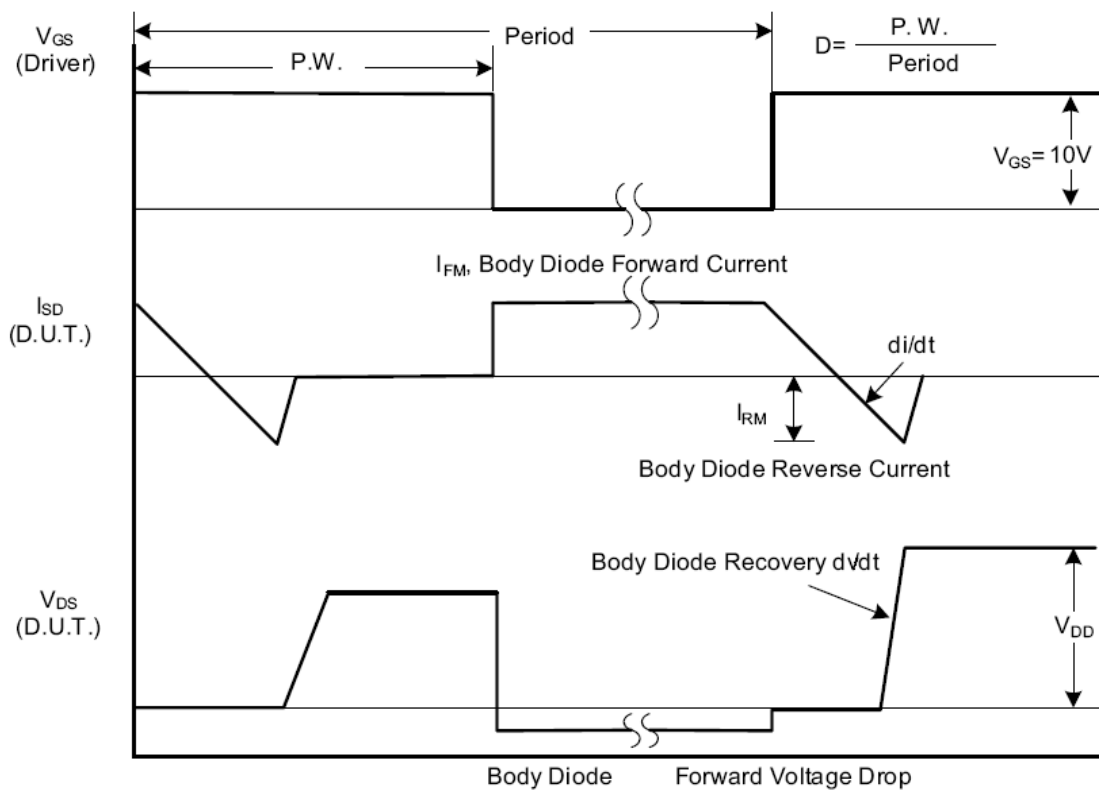

Fig. 1.2 Peak Diode Recovery  $dv/dt$  Waveforms

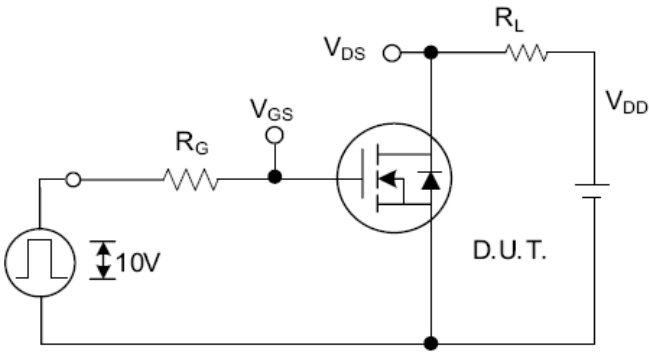

Fig. 2.1 Switching Test Circuit

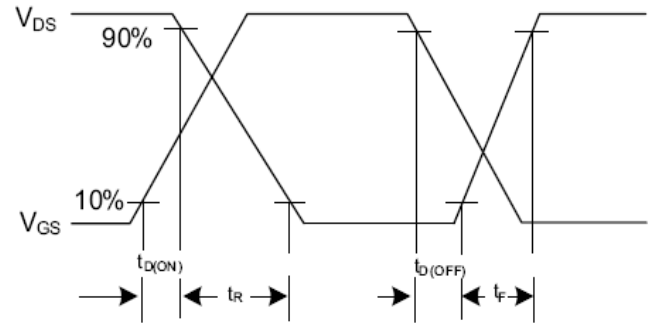

Fig. 2.2 Switching Waveforms

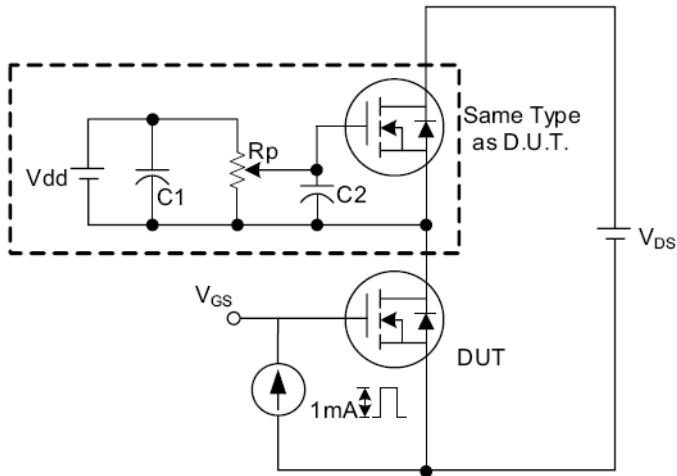

Fig. 3.1 Gate Charge Test Circuit

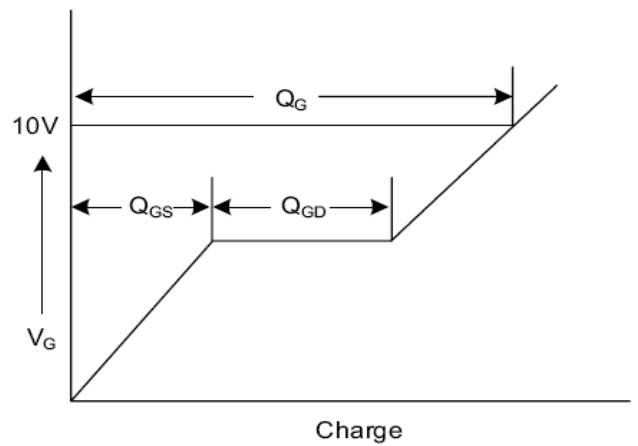

Fig. 3.2 Gate Charge Waveform

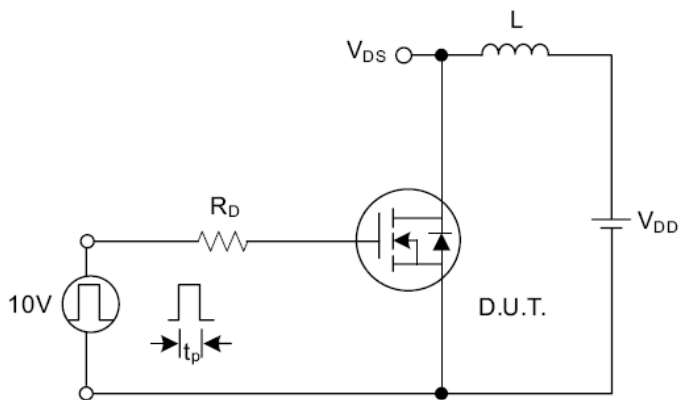

Fig. 4.1 Unclamped Inductive Switching Test Circuit

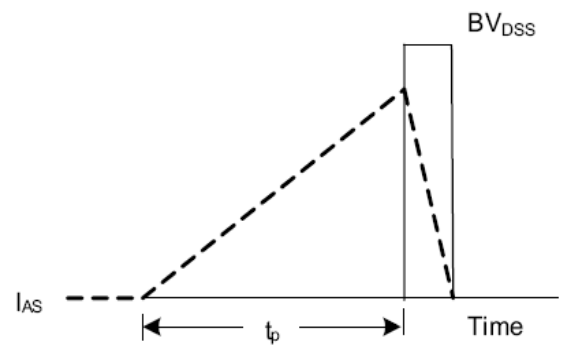
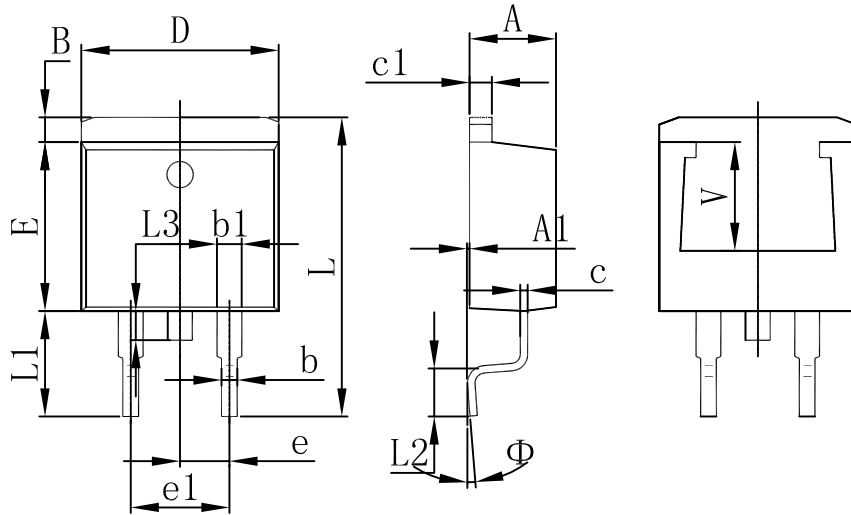

Fig. 4.2 Unclamped Inductive Switching Waveforms



**TO-263 Package Outline Dimensions**



Symbol	Dimensions In Millimeters		Dimensions In Inches	
	Min.	Max.	Min.	Max.
A	4.470	4.670	0.176	0.184
A1	0.000	0.150	0.000	0.006
B	1.120	1.420	0.044	0.056
b	0.710	0.910	0.028	0.036
b1	1.170	1.370	0.046	0.054
c	0.310	0.530	0.012	0.021
c1	1.170	1.370	0.046	0.054
D	10.010	10.310	0.394	0.406
E	8.500	8.900	0.335	0.350
e	2.540 TYP.		0.100 TYP.	
e1	4.980	5.180	0.196	0.204
L	14.940	15.500	0.588	0.610
L1	4.950	5.450	0.195	0.215
L2	2.340	2.740	0.092	0.108
L3	1.300	1.700	0.051	0.067
Φ	0°	8°	0°	8°
V	5.600 REF.		0.220REF.	



### Attention

- Any and all HUA XUAN YANG ELECTRONICS products described or contained herein do not have specifications that can handle applications that require extremely high levels of reliability, such as life-support systems, aircraft's control systems, or other applications whose failure can be reasonably expected to result in serious physical and/or material damage. Consult with your HUA XUAN YANG ELECTRONICS representative nearest you before using any HUA XUAN YANG ELECTRONICS products described or contained herein in such applications.
- HUA XUAN YANG ELECTRONICS assumes no responsibility for equipment failures that result from using products at values that exceed, even momentarily, rated values (such as maximum ratings, operating condition ranges, or other parameters) listed in products specifications of any and all HUA XUAN YANG ELECTRONICS products described or contained herein.
- Specifications of any and all HUA XUAN YANG ELECTRONICS products described or contained herein stipulate the performance, characteristics, and functions of the described products in the independent state, and are not guarantees of the performance, characteristics, and functions of the described products as mounted in the customer's products or equipment. To verify symptoms and states that cannot be evaluated in an independent device, the customer should always evaluate and test devices mounted in the customer's products or equipment.
- HUA XUAN YANG ELECTRONICS CO.,LTD. strives to supply high-quality high-reliability products. However, any and all semiconductor products fail with some probability. It is possible that these probabilistic failures could give rise to accidents or events that could endanger human lives, that could give rise to smoke or fire, or that could cause damage to other property. When designing equipment, adopt safety measures so that these kinds of accidents or events cannot occur. Such measures include but are not limited to protective circuits and error prevention circuits for safe design, redundant design, and structural design.
- In the event that any or all HUA XUAN YANG ELECTRONICS products(including technical data, services) described or contained herein are controlled under any of applicable local export control laws and regulations, such products must not be exported without obtaining the export license from the authorities concerned in accordance with the above law.
- No part of this publication may be reproduced or transmitted in any form or by any means, electronic or mechanical, including photocopying and recording, or any information storage or retrieval system, or otherwise, without the prior written permission of HUA XUAN YANG ELECTRONICS CO.,LTD.
- Information (including circuit diagrams and circuit parameters) herein is for example only ; it is not guaranteed for volume production. HUA XUAN YANG ELECTRONICS believes information herein is accurate and reliable, but no guarantees are made or implied regarding its use or any infringements of intellectual property rights or other rights of third parties.
- Any and all information described or contained herein are subject to change without notice due to product/technology improvement, etc. When designing equipment, refer to the "Delivery Specification" for the HUA XUAN YANG ELECTRONICS product that you intend to use.