

RECOMMEND P.C.B LAYOUT (COMPONENT SIDE)  
TOLERANCE FOR PCB LAYOUT IS  $\pm 0.05$

REV. (版本号)	DESCRIPTION (变更说明)	DATE (日期)	APPD (核准)
A0	新订图面	2022.06.13	Yuxiang

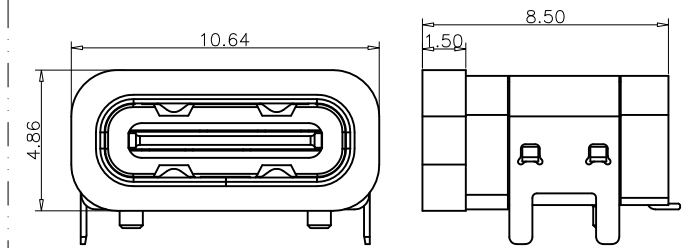

加防水圈示意图

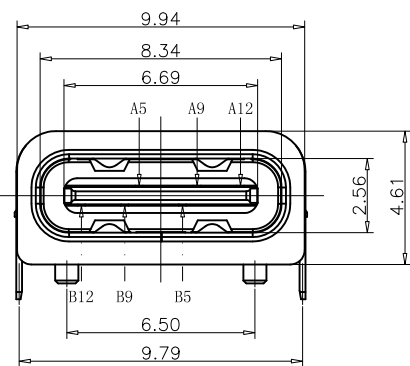
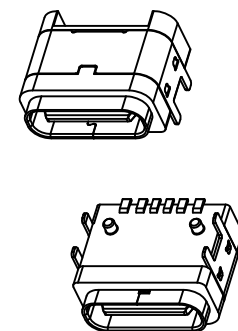
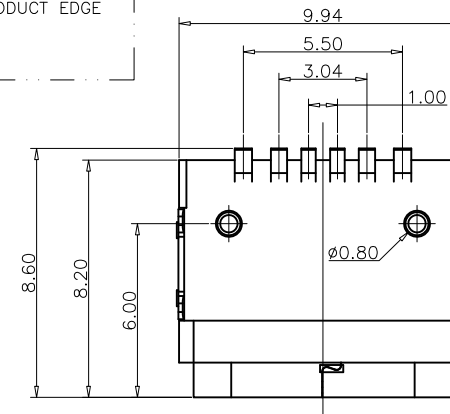
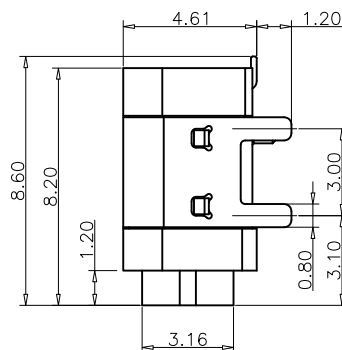
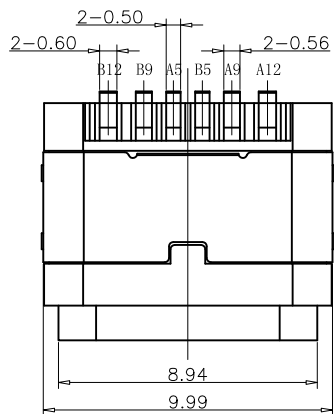

- NOTES:  
SPECIFICATION:  
1.CURRENT RATING: 3.0A MAX  
2.VOLTAGE: 100 VAC  
3.TEMPERATURE RANGE: -30°C~+85°C  
4.CONTACT RESISTANCE: 40 MILLIONHM MAX  
5.INSULATION RESISTANCE: 100 MEGOHMS MIN  
6.INSERTION FORCE: 5N~20N  
7.UNMATING FORCE: 8N~20N  
8.DURABILITY: 10000 CYCLES  
9.WATER PROOFNESS: THIS PRODUCT IS BASED ON IPX7.

TABLE:

NO	PART	Q'TY	Material
1	SHELL	1	STAINLESS STEEL, NI PLATED
2	CONTACT	6	COPPER STEEL, TIN/AU/NI PLATED
3	MID PLATE	1	STAINLESS STEEL, NO PLATING
4	1MD HOUSING	1	HIGH TEMPERATURE RESISTANT PLASTIC BLACK UL94 V-0
5	2MD HOUSING	1	HIGH TEMPERATURE RESISTANT PLASTIC BLACK UL94 V-0
6	SHIELDING PLATE	1	STAINLESS STEEL, NI PLATED

PIN ASSIGNMENT:

PIN NO	A1&B12	A4&B9	A5	B5	A9&B4	A12&B1
SIGNAL NAME	GND	VBUS	CC1	CC2	VBUS	GND
PCB PAD NO.	C1	C2	C3	C4	C5	C6

端子 1A/1B  
中隔片 1A  
外壳 1B  
屏蔽壳 4A

**YWF** 深圳市宇文发电子科技有限公司  
Shen Zhen Yu Wen Fa Electronics Technology Co., Ltd  
TEL: 0755-27711235 FAX: 0755-27712683

品名 (ITEM NO)	TYPE C 6P 板上防水母座-减胶款 (外壳4脚插板, 端子SMT)
料号 (PART NO)	PTCFW-H22B-018
图号 (DWG NO)	P-TCF-094

页码 (SHEET)	1/1	单位 (UNIT):	MM
版本 (REV)	A0	比例 (SCALE):	1:1
日期 (DATE)	2022.06.13		
设计 (DESIGN)	YUXIANG		
审核 (CHECKED)			
核准 (APPROVED)			

未注公差  
TOLERANCE UNSPECIFIED  
X.X  $\pm 0.30$   
X.XX  $\pm 0.20$   
X.XXX  $\pm 0.10$   
X°  $\pm 5°$   
X.X°  $\pm 2°$

# RoHS Compliant

REV.	ECN NO	DESCRIPTION	REVISER	DATE
A/0				
A/1				

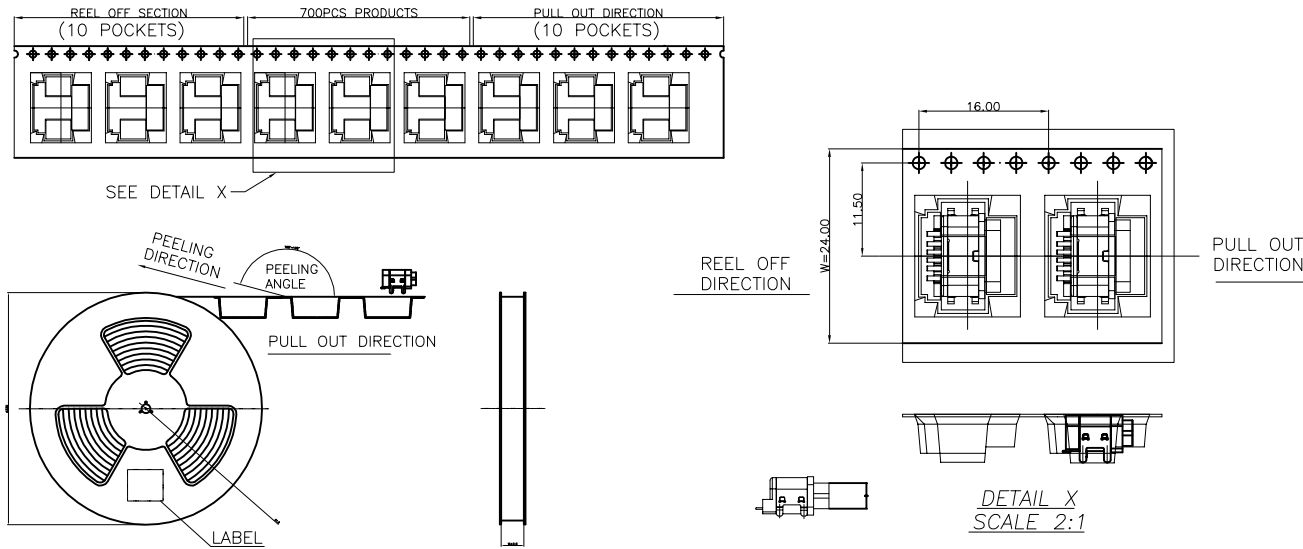

描述:

1. 产品依以上图纸包装方式对成品进行包装, 载带前空10PCS, 从第11格开始放置产品, 放满700PCS后再将载带尾部空置10PCS不放产品;
2. 产品包装好后再用保护带将载带固定在卷盘上, 再在四周贴上3PCS美纹胶;
3. 每盘产品需要使用真空袋单独抽真空包装, 然后在真空袋上贴上内标签.
4. 将1PCS隔板放入内箱底部, 再将真空好的10包产品放入外箱中, 最后在最上层盖上1PCS隔板, 共计7000PCS/箱;
5. 纸箱封盖后以封箱胶封箱, 再套入外箱, 并在外箱的右上角贴上外箱标签环保标签;
6. 未满之零数箱, 需以缓冲材料填满, 并粘贴尾数标签.

	REEL	CARTON
CONNECTOR (PCS)	700	7000

## \*内盘标签样式

Item No.:	USBXXXX-XX-X	→ 料 號
Batch No:	200921-001	→ 樣式為“YYMMDD-001”, 請按生產批次的年月日來填寫
Quantity:	700 PCS	→ 每卷轉載貨數量

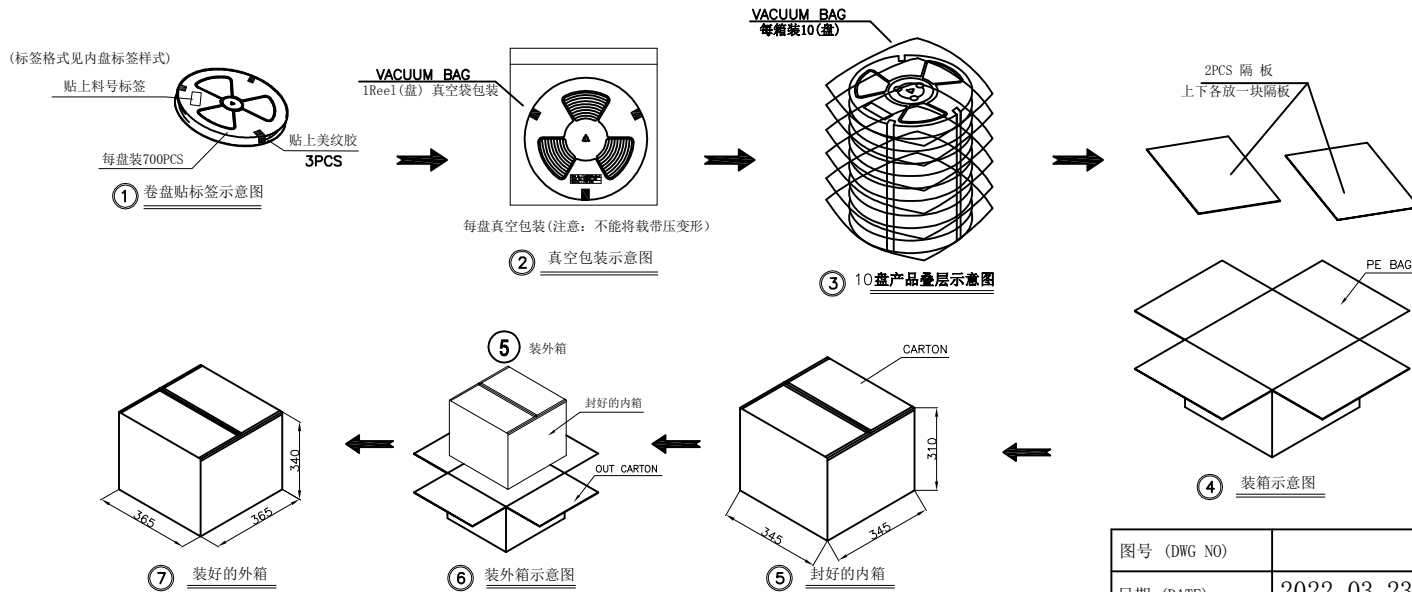

NOTE:

1. QUANTITY: 700 PCS/REEL, 7000PCS/CARTON.

NO.	包材名称	用量	备注
①	纸 箱	1	340*340*320mm, K=K
②	外 箱	1	345*345*330mm, K=K
③	真空袋	10	透明色
④	载 带	10	W=24mm, 透明PET
⑤	自粘上带	—	自粘上带
⑥	塑胶卷轴	10	Ø330mm, W=24.5mm
⑦	保护带	10	透明色
⑧	隔 板	2	
⑨	环保标签	1	
⑩	内标签	10	
⑪	外标签	1	
⑫	产品	7000	
⑬	美纹胶	30	

图号 (DWG NO)		单位 (UNIT):	MM	
日期 (DATE)	2022. 03. 23	比例 (SCALE)	1:1	
版次 (REV):	A/0	页/次 (PAGE):	1/1	
设计 (DESIGN)	YUXIANG	包装规范	品名 (ITEM NO)	TYPE C 母座 6P防水 包装图 GCT专用
审核 (CHECKED)			料号 (PART NO)	A-004R-141
核准 (APPROVED)				

**深圳市宇文发电子科技有限公司**  
 Shen Zhen Yu Wen Fa Electronics Technology Co., Ltd  
 TEL: 0755-27711235 FAX: 0755-27712683