

REV. (版本号)	DESCRIPTION (变更说明)	DATE (日期)	APPD (核准)
A0	新订图面	2021.01.21	ZHUANG

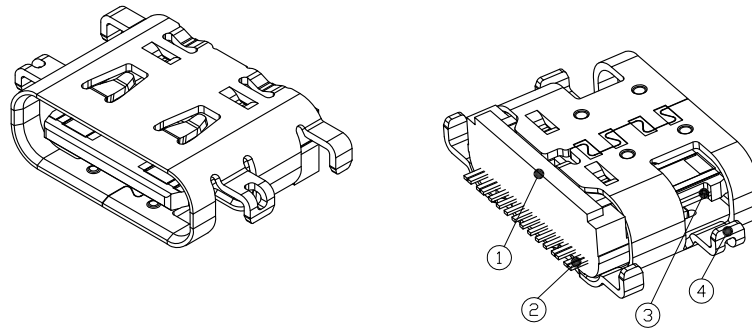
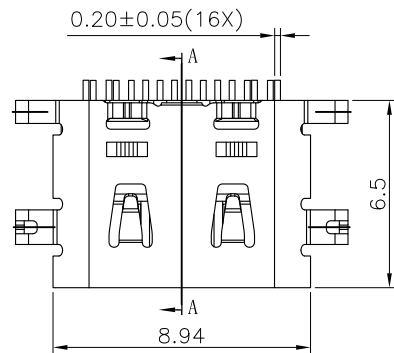

NOTE:

1.MATERIAL SPECIFICATION:

- 1.HOUSING:HIGH TEMPERATURE RESISTANT PLASTIC(LCP),UL94 V-0.
- 2.CONTACTS:COPPER ALLOY(C1814)T=0.12mm
- 3.MID PLATE: STAINLESS STEEL(SUS301)T=0.15mm
- 4.SHELL: STAINLESS STEEL(SUS304)T=0.30mm

2.PLATING SPECIFICATION:

2-1.CONTACTS:

- Ni 50u" MIN. UNDER PLATED OVER ALL.
- Au PLATED ON THE FUNCTIONAL AREA OF CONTACT.
- (GOLD PLATING THICKNESS FOLLOW THE P/N)
- PLATING SPECIFICATIONS OF THE SOLDER AREA FOLLOW THE P/N

2-2.FRONT SHELL:

- Ni 30u" MIN. UNDER PLATED OVER ALL.

2-3.MID PLATE:

- CLEAR ONLY

3.MECHANICAL PERFORMANCE,

- 3-1.INSERTION FORCE: 0.5~2.0kgf.
- 3-2.EXTRACTION FORCE: 0.8kgf~2.0kgf.
- 3-3.DURABILITY: 10000 CYCLES.

4.ELECTRICAL PERFORMANCE,

- 4-1. CURRENT RATING:5.0A
- VOLTAGE RATING:5.0V
- 4-2. LLCR:
VBUS & GND PINS AND OTHER PINS: 40mΩ/PIN MAX.
SHIELD: 50mΩ/MAX.
LLCR MAX. CHANGE OF ALL PINS: 10mΩ.
- 4-3.INSULATION RESISTANCE: 100MΩ MIN
- 4-4.DIELECTRIC WITHSTAND VOLTAGE,AC 100V FOR 1 MINUTE.

5. ENVIRONMENTAL PERFORMANCE:

- OPERATING TEMPERATURE: -25°C~+85°C.

6.IR REFLOW:

- THE PEAK TEMPERATURE ON THE BOARD SHALL BE MAINTAINED FOR 10 SECONDS AT 260°C.

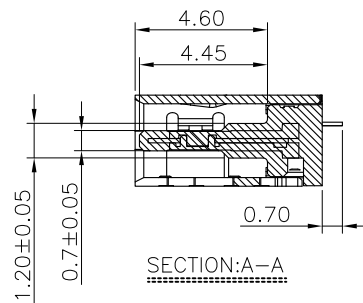
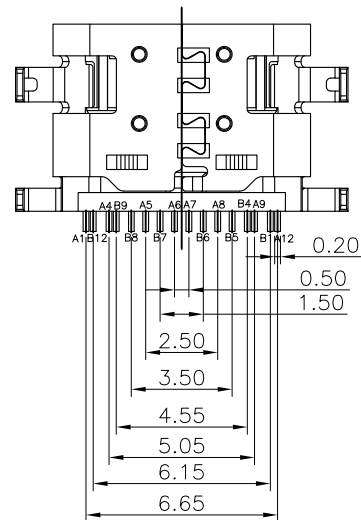
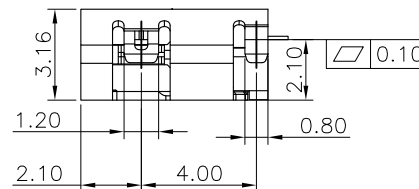
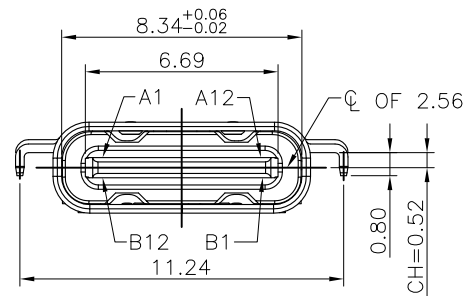

 深圳市宇文发电子科技有限公司 Shen Zhen Yu Wen Fa Electronics Technology Co.,Ltd TEL:0755-27711235 FAX:0755-27712683		页码 (SHEET)	1/2	单位(UNIT): MM
		版本 (REV)	A0	比例(SCALE) 1:1
品名 (ITEM NO)	TYPE C 母座 16P 沉板 2.10 成品	日期 (DATE)	2021.01.26	 未注公差 TOLERANCE UNSPECIFIED X.X ±0.30 X.XX ±0.20 X.XXX ±0.10 X° ±5° X.X° ±2°
料号 (PART NO)	PTCFW-H22A-031	设计 (DESIGN)	ZHUANG	
图号 (DWG NO)		审核 (CHECKED)		
		核准 (APPROVED)		

REV. (版本号)	DESCRIPTION (变更说明)	DATE (日期)	APPD (核准)
A0	新订图面	2021.01.26	ZHUANG

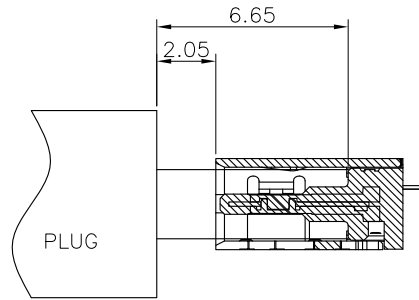

AFTER MATING

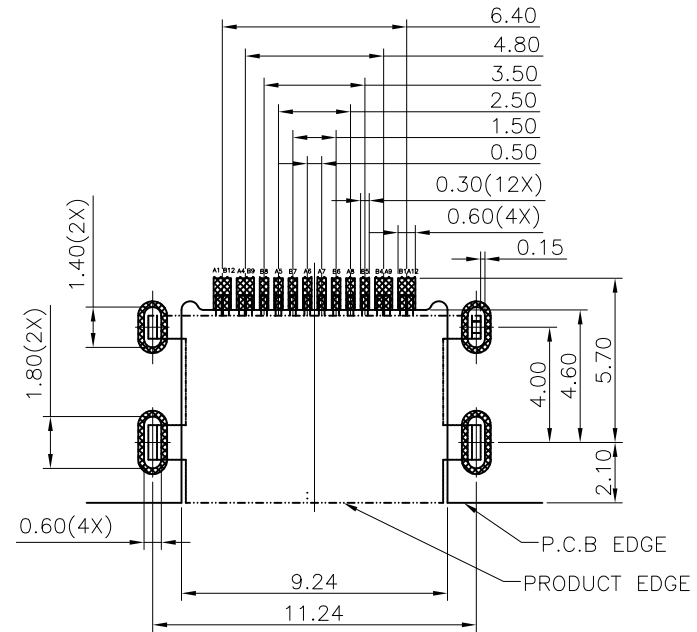

RECOMMENDED PCB LAYOUT(TOP VIEW)
THICKNESS 0.80MM;DEFAULT TOLERANCE:±0.05

USB TYPE-C PIN ASSIGNMENTS

PIN NUMBER	SIGNAL NAME	PIN NUMBER	SIGNAL NAME
A1	GND	B12	GND
A4	VBUS	B9	VBUS
A5	CC1	B8	SBU2
A6	Dp1	B7	Dn2
A7	Dn1	B6	Dp2
A8	SBU1	B5	CC2
A9	VBUS	B4	VBUS
A12	GND	B1	GND

 深圳市宇文发电子科技有限公司 Shen Zhen Yu Wen Fa Electronics Technology Co.,Ltd TEL:0755-27711235 FAX:0755-27712683	页码 (SHEET)	2/2	单位(UNIT): MM
	版本 (REV)	A0	比例(SCALE) 1:1
	日期 (DATE)	2021.01.26	
	设计 (DESIGN)	ZHUANG	未注公差 TOLERANCE UNSPECIFIED
	审核 (CHECKED)		X.X ±0.30 X.XX ±0.20 X.XXX ±0.10 X° ±5° X.X° ±2°
品名 (ITEM NO)	TYPE C 母座 16P 沉板2.10 成品		核准 (APPROVED)
料号 (PART NO)	PTCFW-H22A-031		
图号 (DWG NO)			

REV. (版本号)	DESCRIPTION (变更说明)	DATE (日期)	APPD (核准)
A0	新订图面	2021.01.27	ZHUANG

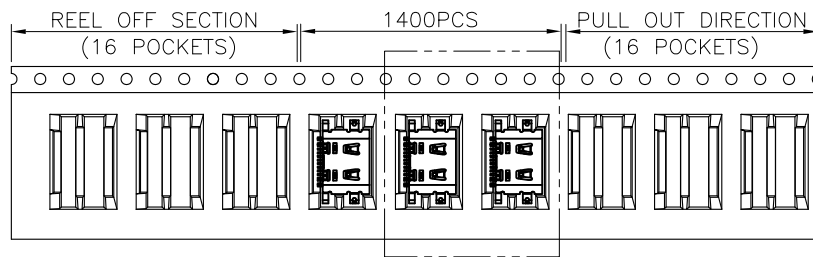

SEE DETAIL X

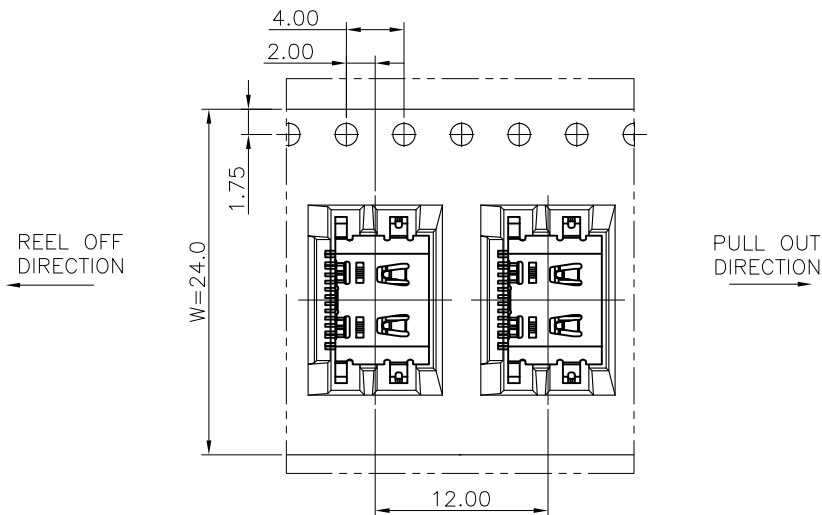
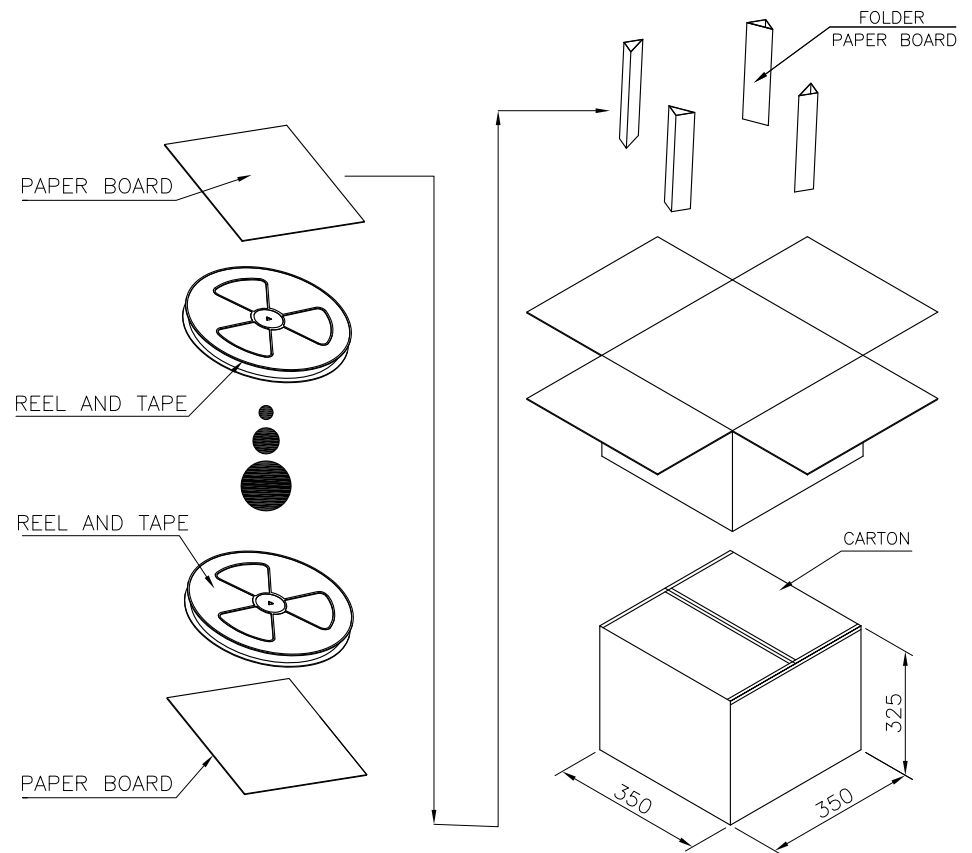
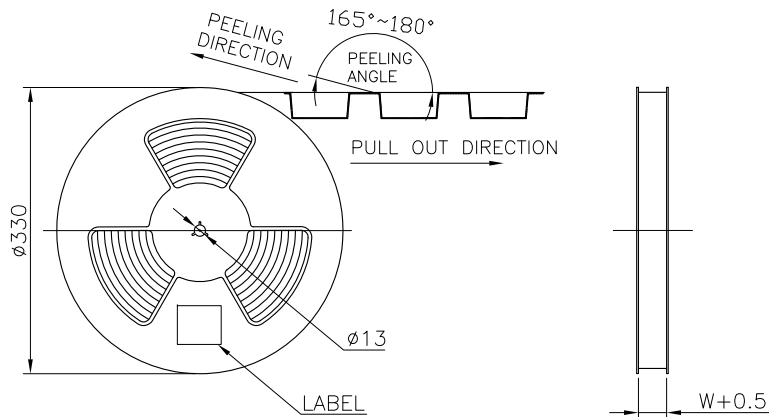

 深圳市宇文发电子科技有限公司 Shen Zhen Yu Wen Fa Electronics Technology Co.,Ltd TEL:0755-27711235 FAX:0755-27712683	页码 (SHEET)	3/3	单位(UNIT): MM
	版本 (REV)	A0	比例(SCALE) 1:1
品名 (ITEM NO)	TYPE C 母座 16P 沉板2.10 成品包规	日期 (DATE)	2021.01.27
料号 (PART NO)	A-004R-092	设计 (DESIGN)	ZHUANG
图号 (DWG NO)		审核 (CHECKED)	
		核准 (APPROVED)	
			未注公差 TOLERANCE UNSPECIFIED X.X ±0.30 X.XX ±0.20 X.XXX ±0.10 X° ±5° X.X° ±2°