

NOTE:

1.MATERIAL SPECIFICATION:

- 1.HOUSING:HIGH TEMPERATURE RESISTANT PLASTIC,UL94 V-0.
- 2.TERMINAL: COPPER ALLOY(C18150)
- 3.MID PLATE: STAINLESS STEEL(SUS301)
- 4.FRONT SHELL: STAINLESS STEEL(SUS304)

2.PLATING SPECIFICATION:

2-1.TERMINAL:

- Ni 50u" MIN. UNDER PLATED OVER ALL.
- Au 1u" PLATED ON THE FUNCTIONAL AREA OF CONTACT.
- Au G/F PLATED ON THE SOLDER AREA.

2-2.FRONT SHELL:

- Ni 30u" MIN. UNDER PLATED OVER ALL.

2-3.MID PLATE PLATE:

- CLEAR ONLY

3.MECHANICAL PERFORMANCE,

- 3-1.INSERTION FORCE: 0.5~2.0kgf.
- 3-2.REMOVAL FORCE: 0.8kgf~2.0kgf.
- 3-3.DURABILITY: 10000 CYCLES.

4.ELECTRICAL PERFORMANCE,

- 4-1. VOLTAGE RATING: 5V.
- CURRENT RATING: 5A.
- 4-2. LLCR:
 - VBUS & GND PINS AND OTHER PINS: 40mA/PIN MAX.
 - LLCR MAX. CHANGE OF ALL PINS: 10mA.
- 4-3.INSULATION RESISTANCE: 100MΩ MIN
- 4-4.DIELECTRIC WITHSTAND VOLTAGE,AC 100V FOR 1 MINUTE.

5. ENVIRONMENTAL PERFORMANCE:

- OPERATING TEMPERATURE: -40C~+85°C.

6.IR REFLOW:

- THE PEAK TEMPERATURE ON THE BOARD SHALL BE MAINTAINED FOR 10 SECONDS AT 260°C.

制图 DRAWN	变更内容 DESCRIPTION	日期 DATE	GENERAL TOLERANCE		制图 DRAWING	EMMA		料号 PART NO.	BX-TYPEC-WTM16-L835		版本 REV.	A
			.X±0.30	X'±10°	审核 CHECK	EVA		品名 TITLE	USB CF 16PIN (L=8.35) WITH POST		页次 SHEET	1/1
			.XX±0.20	.X'±8°	核准 APPROVAL	JADE		客户料号 CUTM.NO.				
			.XXX±0.10	.XX'±5°	单位 UNITS	MM	比例 SCALE	1:1				

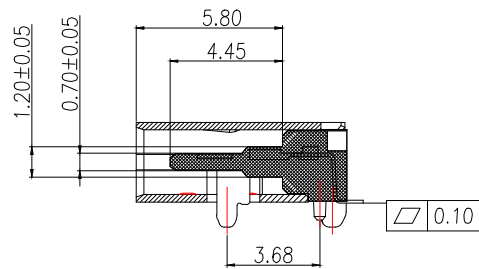

SECTION:A-A

USB TYPE-C PIN ASSIGNMENTS

PIN NUMBER	SIGNAL NAME	PIN NUMBER	SIGNAL NAME
A1	GND	B12	GND
A4	VBUS	B9	VBUS
A5	CC1	B8	SBU2
A6	Dp1	B7	Dn2
A7	Dn1	B6	Dp2
A8	SBU1	B5	CC2
A9	VBUS	B4	VBUS
A12	GND	B1	GND

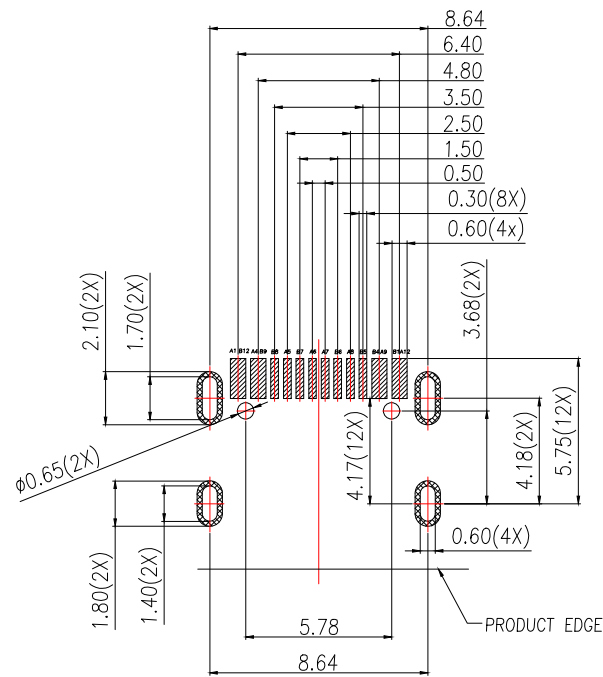

RECOMMENDED PCB LAYOUT(TOP VIEW)
THICKNESS 1.00MM;DEFAULT TOLERANCE:±0.05

制图 DRAWN	变更内容 DESCRIPTION	日期 DATE	GENERAL TOLERANCE		制图 DRAWING	EMMA	料号 PART NO.	BX-TYPEC-WTM16-L835	版本 REV.	A
			.X±0.30	X.*±10°						
.XX±0.20	.X.*±8°	核准 APPROVAL	JADE	客户料号 CUTM.NO.						
.XXX±0.10	.XX.*±5°				单位 UNITS	MM	比例 SCALE	1:1		

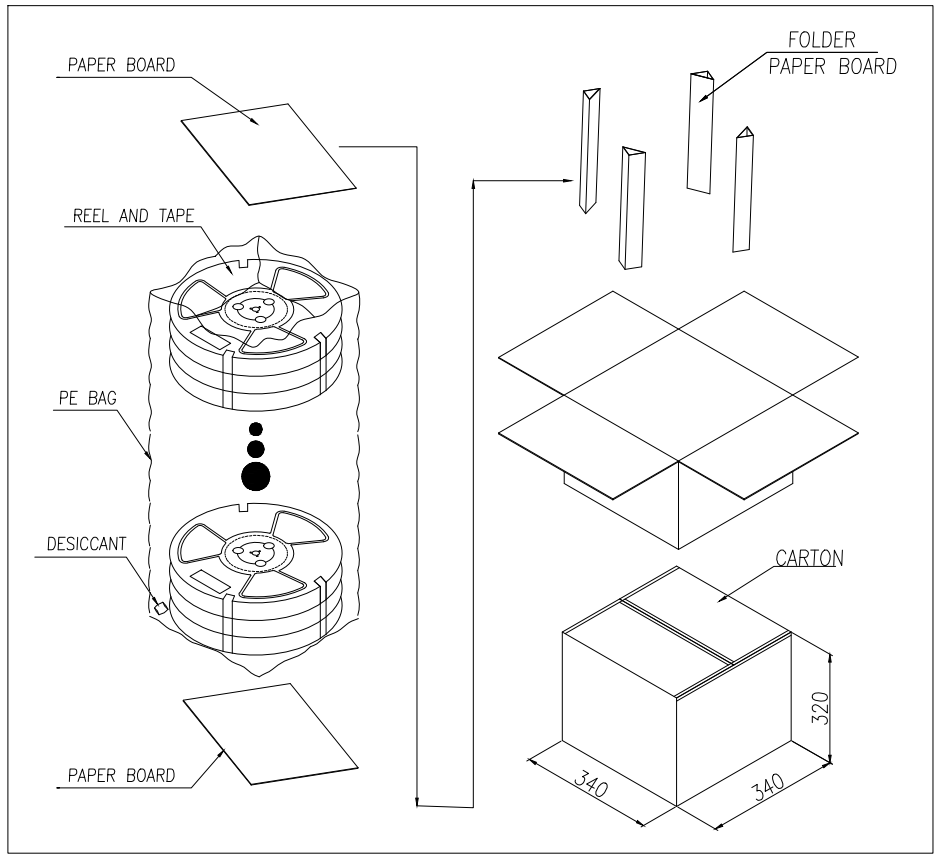
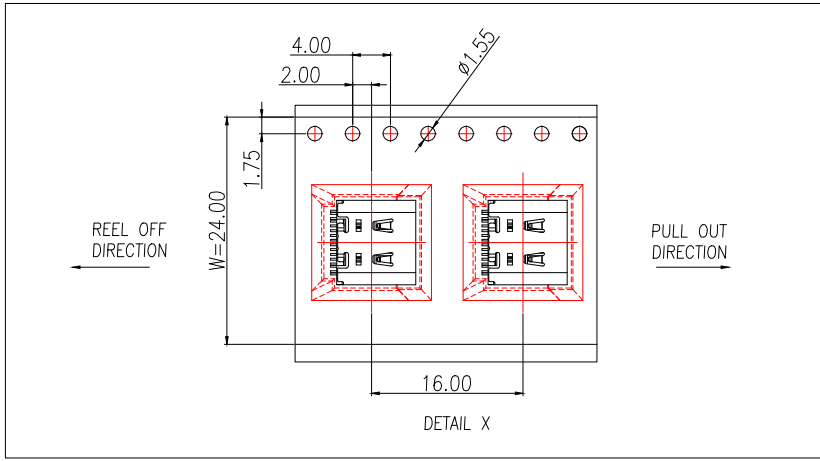
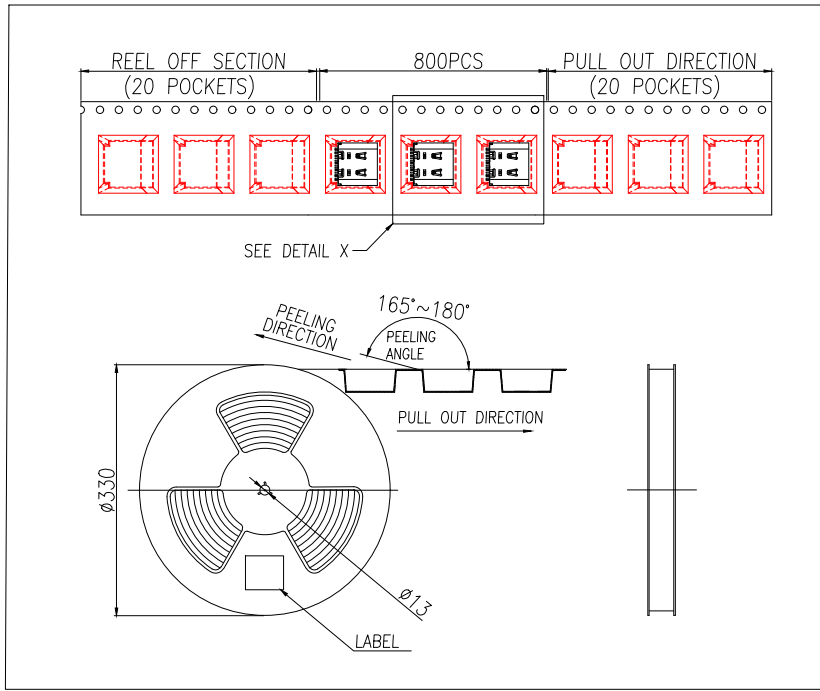

	REEL	CARTON
CONNECTOR (PCS)	800	8000

制图 DRAWN	变更内容 DESCRIPTION	日期 DATE	GENERAL TOLERANCE		制图 DRAWING	EMMA	料号 PART NO.	BX-TYPEC-WTM16-L835		版本 REV.	A		
			.X \pm 0.30	X. \pm 10°				品名 TITLE	USB CF 16PIN (L=8.35) WITH POST			页次 SHEET	1/1
			.XX \pm 0.20	.X \pm 8°									
			.XXX \pm 0.10	.XX \pm 5°									
			审核 CHECK	EVA	客户料号 CUTM.NO.								
			核准 APPROVAL	JADE									
			单位 UNITS	MM	比例 SCALE	1:1							