

1. DESCRIPTION

The XL285-2.5/XL385-2.5 are micropower 2-terminal band-gap voltage regulator diodes. Operating over a 20 μ A to 20 mA current range, they feature exceptionally low dynamic impedance and good temperature stability. On-chip trimming is used to provide tight voltage tolerance.

2. FEATURES

- ± 20 mV ($\pm 0.8\%$) max. Initial Tolerance (A Grade)
- Operating Current of 20 μ A to 20 mA
- 0.6 Ω Dynamic Impedance (A Grade)
- Low Temperature Coefficient
- Low Voltage Reference—2.5V

3. CONNECTION DIAGRAM

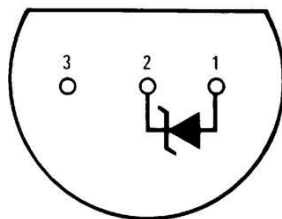

Figure 1.TO-92

(Bottom View)

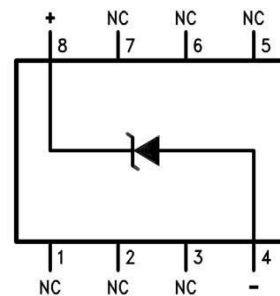
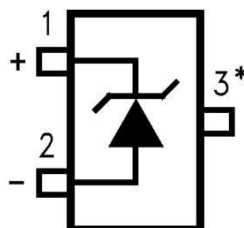

Figure 2. SOP



*Pin 3 is attached to the Die Attach Pad (DAP) and should be connected to Pin 2 or left floating

Figure 3. SOT23-3

4. ABSOLUTE MAXIMUM RATINGS⁽¹⁾⁽²⁾

Reverse Current		30 mA
Forward Current		10 mA
Operating Temperature Range ⁽³⁾	XL285-2.5	-40°C to + 85°C
	XL385-2.5	-40°C to + 85°C
ESD Susceptibility ⁽⁴⁾		2kV
Storage Temperature		-55°C to + 150°C
Soldering Information	TO-92 Package (10 sec.)	
	SOP and SOT-23 Package	Vapor Phase (60 sec.)
		Infrared (15 sec.)

(1) Absolute Maximum Ratings indicate limits beyond which damage to the device may occur. Operating Ratings indicate conditions for which the device is intended to be functional, but do not ensure specific performance limits. For ensured specifications and test conditions, see the Electrical Characteristics. The ensured specifications apply only for the test conditions listed.

(2) For elevated temperature operation, TJMAX is

: XL285: 125°C
XL385: 100°C

(3) The human body model is a 100 pF capacitor discharged through a 1.5 kΩ resistor into each pin

5. THERMAL CHARACTERISTICS

over operating free-air temperature range (unless otherwise noted)

Thermal Resistance	XL285	125°C	SOP-8	SOT-23
	XL385	100°C		
TO-92				
θ_{ja} (Junction to Ambient)	180°C/W (0.4" Leads)		165°C/W	283°C/W
	170°C/W (0.125" Leads)			
θ_{jc} (Junction to Case)	N/A		N/A	N/A

6. ELECTRICAL CHARACTERISTICS

Parameter	Conditions	Typ	XL385-2.5		Units (Limits)
			Tested Limit ⁽²⁾	Design Limit ⁽³⁾	
Reverse Breakdown Voltage	$I_R = 100 \mu\text{A}$	2.500	2.480 2.520	2.470 2.530	V(Min) V(Max) V(Min) V(Max)
Minimum Operating Current		12	18	20	μA (Max)
Reverse Breakdown Voltage Change with Current	$I_{\text{MIN}} \leq I_R \leq 1\text{mA}$ $1\text{mA} \leq I_R \leq 20\text{mA}$		1 10	1.5 20	mV (Max) mV (Max)
Reverse Dynamic Impedance	$I_R = 100 \mu\text{A}$, $f = 20\text{Hz}$	0.2		0.6 1.5	Ω
Wideband Noise (rms)	$I_R = 100 \mu\text{A}$ $10\text{Hz} \leq f \leq 10\text{kHz}$	120			μV
Long Term Stability	$I_R = 100 \mu\text{A}$, $T = 1000\text{Hr}$, $T_A = 25^\circ\text{C} \pm 0.1^\circ\text{C}$	20			ppm
Average Temperature Coefficient ⁽⁴⁾	$I_{\text{MIN}} \leq I_R \leq 20\text{mA}$ X Suffix Y Suffix All Others		30 50	150	ppm/ $^\circ\text{C}$ (Max)

- (1) Parameters identified with boldface type apply at temperature extremes. All other numbers apply at $T_A = T_J = 25^\circ\text{C}$.
- (2) Specified and 100% production tested.
- (3) Specified, but not 100% production tested. These limits are not used to calculate average outgoing quality levels.
- (4) The average temperature coefficient is defined as the maximum deviation of reference voltage at all measured temperatures between the operating T_{MAX} and T_{MIN} , divided by $T_{\text{MAX}} - T_{\text{MIN}}$. The measured temperatures are -55°C , -40°C , 0°C , 25°C , 70°C , 85°C , 125°C .

ELECTRICAL CHARACTERISTICS

Parameter	Conditions	Typ	XL285-2.5		XL385-2.5		XL385-2.5		Units (Limit)
			Tested Limit ⁽¹⁾⁽²⁾	Design Limit ⁽³⁾	Tested Limit ⁽¹⁾	Design Limit ⁽³⁾	Tested Limit ⁽¹⁾	Design Limit ⁽³⁾	
Reverse Breakdown Voltage	T _A = 25°C, 20 μA ≤ I _R ≤ 20 mA	2.5	2.462 2.538		2.462 2.538		2.425 2.575		V(Min) V(Max)
Minimum Operating Current	XL385-2.5	13	20	30	20	30	20 15	30 20	μA (Max)
Reverse Breakdown Voltage Change with Current	20 μA ≤ I _R ≤ 1 mA		1	1.5	2.0	2.5	2.0	2.5	mV (Max)
	1 mA ≤ I _R ≤ 20 mA		10	20	20	25	20	25	mV (Max)
Reverse Dynamic Impedance	I _R = 100 μA, f = 20 Hz	1							Ω
Wideband Noise (rms)	I _R = 100 μA, 10 Hz ≤ f ≤ 10 kHz	120							μV
Long Term Stability	I _R = 100 μA, T = 1000 Hr, T _A = 25°C ±0.1°C	20							ppm
Average Temperature Coefficient ⁽⁴⁾	I _R = 100 μA								ppm/°C
	X Suffix		30		30				ppm/°C
	Y Suffix		50		50				ppm/°C
	All Others			150		150		150	ppm/°C (Max)

- (1) Specified and 100% production tested.
- (2) Specified, but not 100% production tested. These limits are not used to calculate average outgoing quality levels
- (3) The average temperature coefficient is defined as the maximum deviation of reference voltage at all measured temperatures between the operating T_{MAX} and T_{MIN}, divided by T_{MAX}-T_{MIN}. The measured temperatures are -55°C, -40°C, 0°C, 25°C, 70°C, 85°C, 125°C.

7. TYPICAL PERFORMANCE CHARACTERISTICS

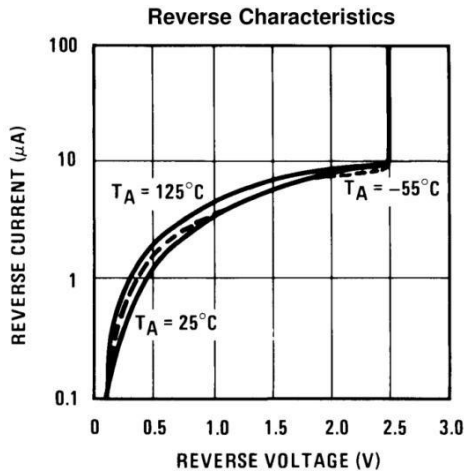

Figure 4.

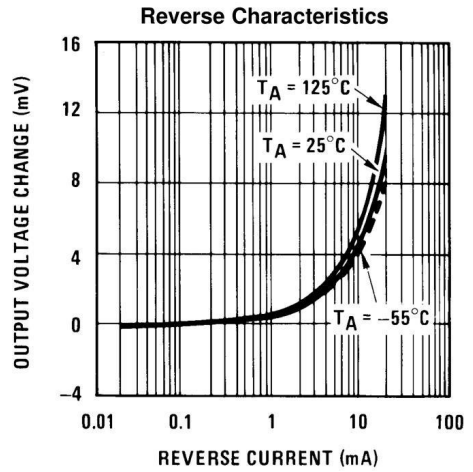

Figure 5.

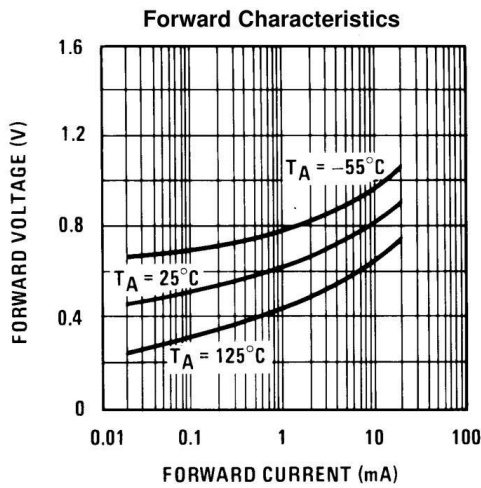

Figure 6.

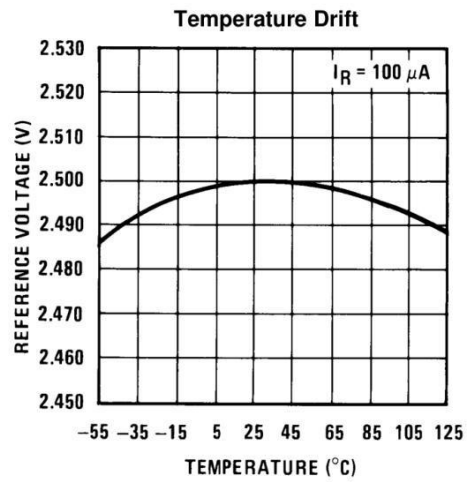

Figure 7.

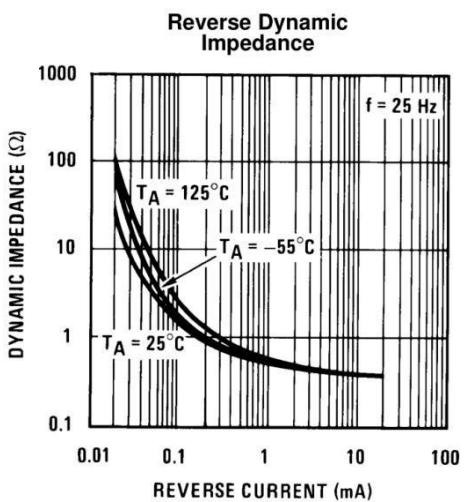

Figure 8.

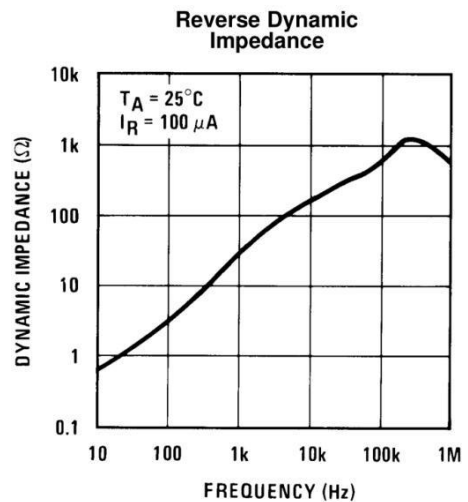

Figure 9.

TYPICAL PERFORMANCE CHARACTERISTICS(continued)

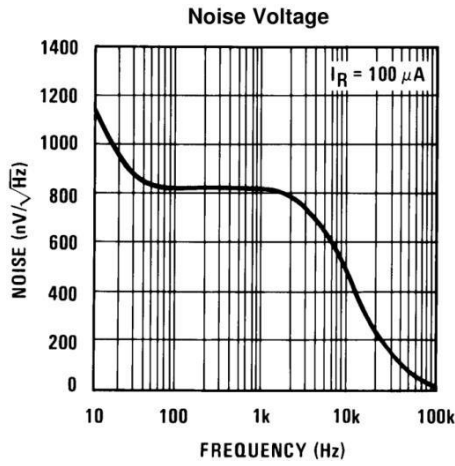

Figure 10.

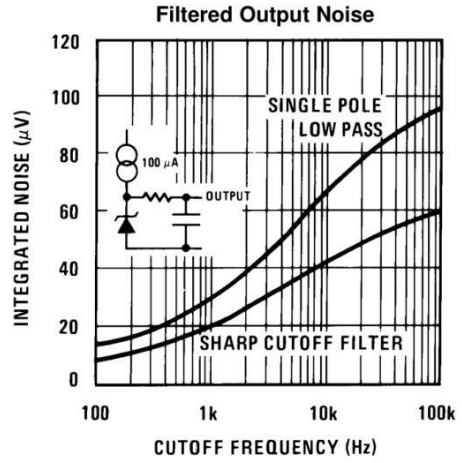

Figure 11.

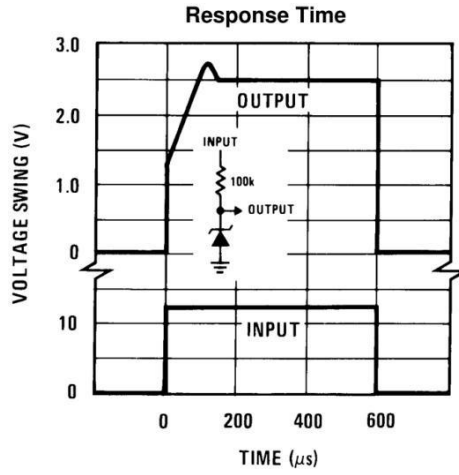

Figure 12.

8. TYPICAL PERFORMANCE CHARACTERISTICS

$V_{IN} = 3.7V \text{ TO } 30V$

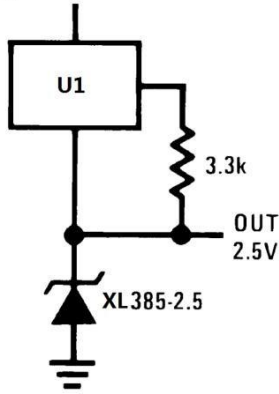

Figure 13. Wide Input Range Reference

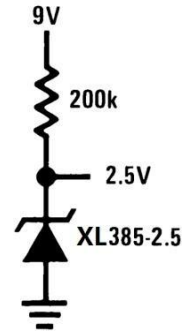
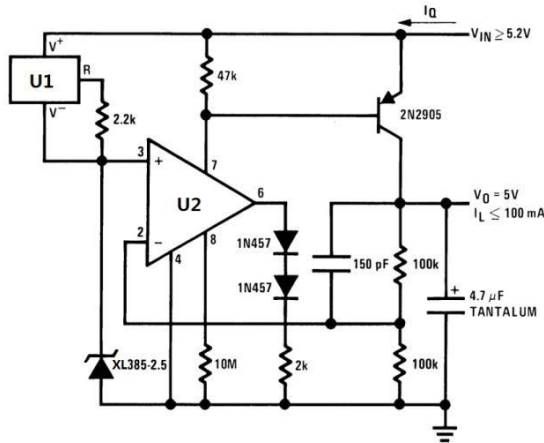

Figure 14. Micropower Reference from 9V Battery

Note 1: U1 uses a constant current source IC, such as an LM334 or equivalent.



$I_Q = 40 \mu A$

Figure 15. Micropower 5V Referencer

Note 2: U2 uses a constant current source IC, such as an LM4250C or equivalent.

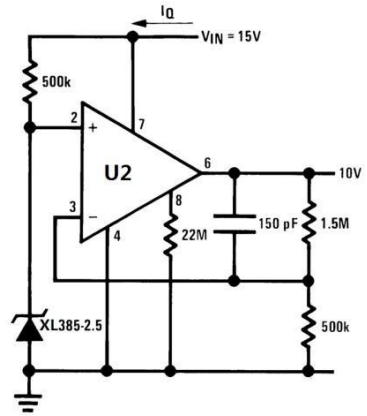

$I_Q = 30 \mu A$ standby current

Figure 16. Micropower 10V Reference

PRECISION 1 μA to 1 mA CURRENT SOURCES

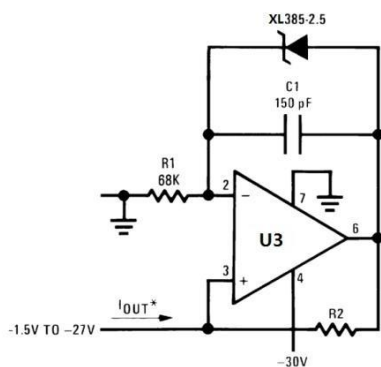

$$I_{OUT} = \frac{2.5V}{R_2}$$

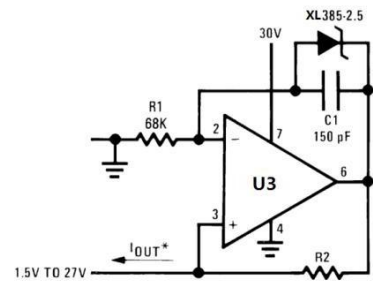
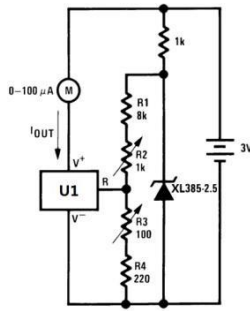

Figure 17.

Note 3: U3 uses a constant current source IC, such as an LM312 or equivalent.



Calibration

1. Short XL385-2.5, adjust R3 for $I_{OUT} = \text{temp}$ at $1\mu\text{A}/^\circ\text{C}$.
2. Remove short, adjust R2 for correct reading in centigrade

Figure 18. $0^\circ\text{C} - 100^\circ\text{C}$ Thermomemter

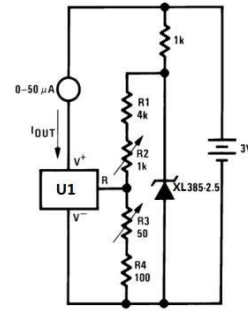

Calibration

1. Short XL385-2.5, adjust R3 for $I_{OUT} = \text{temp}$ at $1.8\mu\text{A}/^\circ\text{C}$
2. Remove short, adjust R2 for correct reading in $^\circ\text{F}$

Figure 19. $0^\circ\text{F} - 50^\circ\text{F}$ Thermomemter

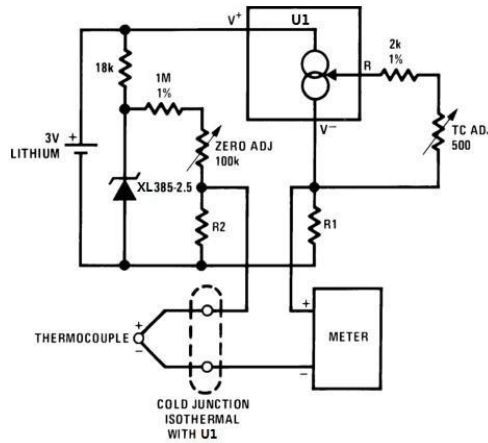

Adjustment Procedure

1. Adjust TC ADJ pot until voltage across R1 equals Kelvin temperature multiplied by the thermocouple Seebeck coefficient.
2. Adjust zero ADJ pot until voltage across R2 equals the thermocouple Seebeck coefficient multiplied by 273.2.

Figure 20. Micropower Thermocouple Cold Junction Compensator

Thermocouple Type ⁽¹⁾	Seebeck Coefficient ($\mu\text{V}/^\circ\text{C}$)	R1 (Ω)	R2 (Ω)	Voltage Across R1 @ 25°C (mV)	Voltage Across R2 (mV)
J	52.3	523	1.24k	15.60	14.32
T	42.8	432	1k	12.77	11.78
K	40.8	412	953 Ω	12.17	11.17
S	6.4	63.4	150 Ω	1.908	1.766

(1) Typical supply current $50\mu\text{A}$

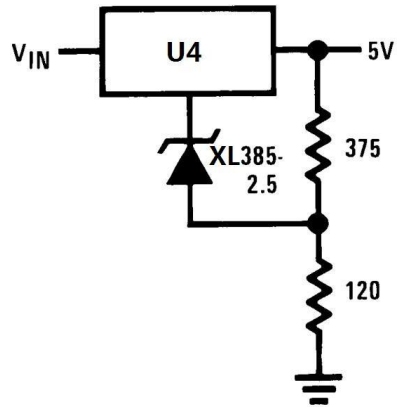
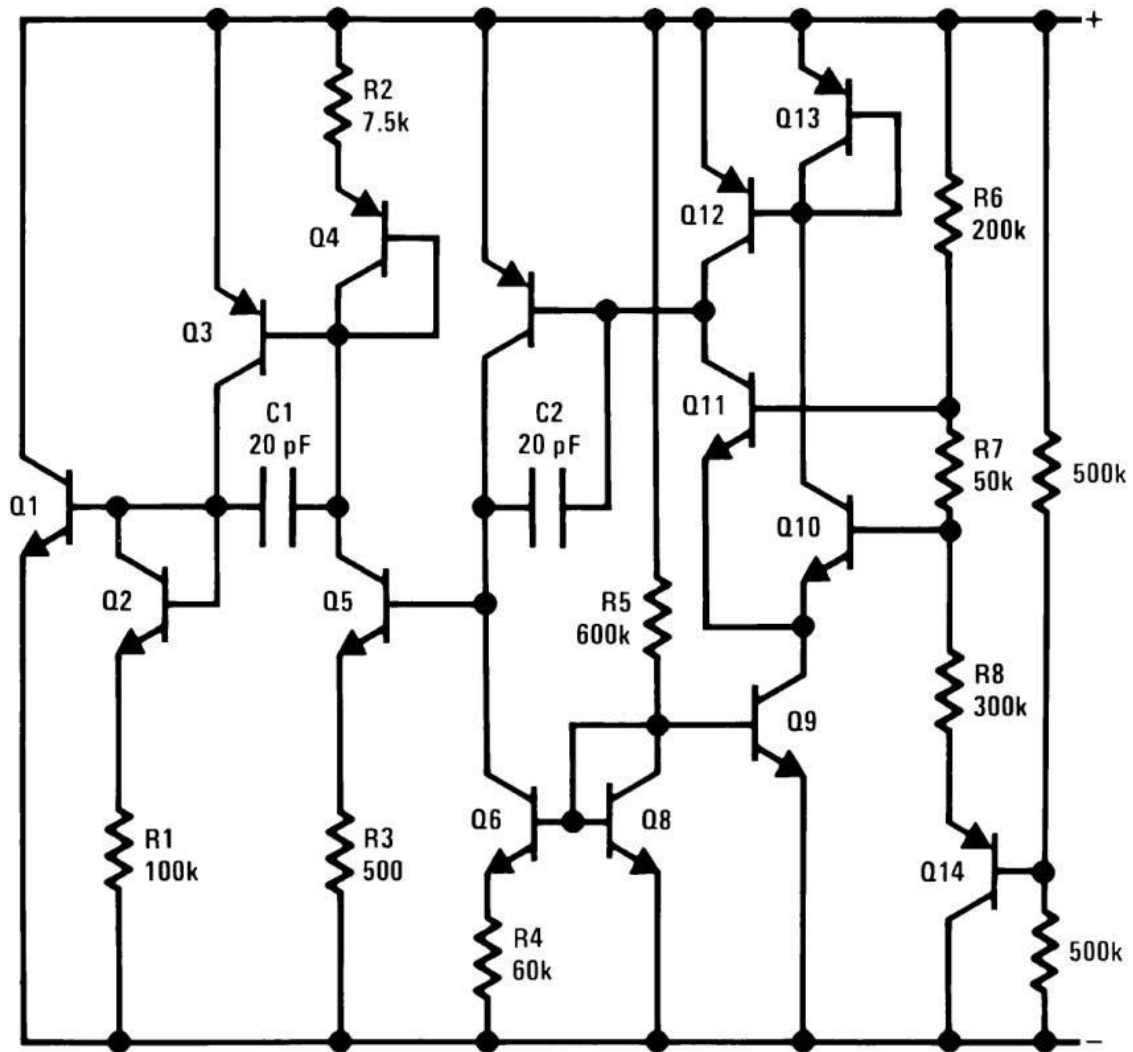

Figure 21. Improving Regulation of Adjustable Regulators

Note 4: U4 uses a constant current source IC, such as an LM338 or equivalent.

9. SCHEMATIC DIAGRAM



10. ORDERING INFORMATION

Ordering Information

Part Number	Device Marking	Package Type	Body size (mm)	Temperature (°C)	MSL	Transport Media	Package Quantity
XL285-2.5	XL285-2.5	SOP8	4.90 * 3.90	- 40 to 85	MSL3	T&R	2500
XT285-2.5	XT285-2.5	TO-92	4.58 * 4.58	- 40 to 85	MSL3	T&R	1000
XL385-2.5	XL385-2.5	SOP8	4.90 * 3.90	- 40 to 85	MSL3	T&R	2500
XT385-2.5	XT385-2.5	TO-92	4.58 * 4.58	- 40 to 85	MSL3	T&R	1000
XB385M3-2.5	R12	SOT23-3	2.90 * 1.30	- 40 to 85	MSL3	T&R	3000

11. DIMENSIONAL DRAWINGS

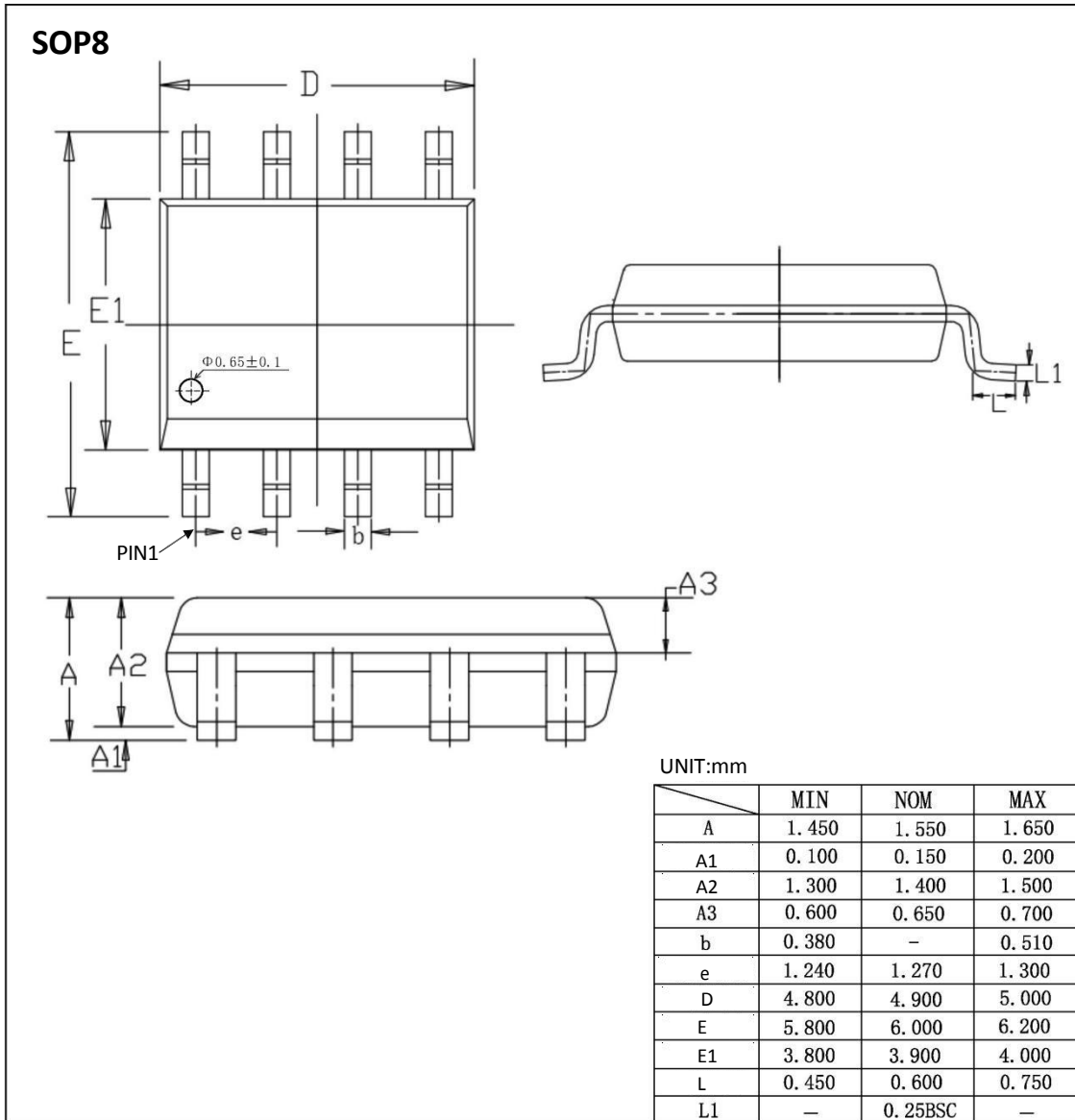

TO-92

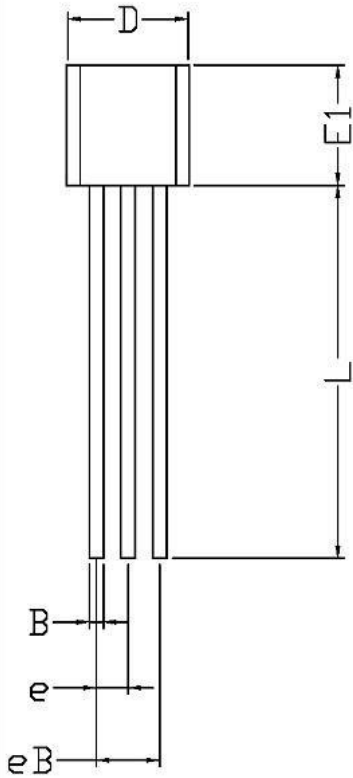

SYMBOL	MIN	MAX
A	3.46	3.96
A1	1.02 TYP	
B	0.36	0.56
C	1.80 TYP	
D	4.33	4.83
E1	4.33	4.83
E	3.35	3.85
eB	2.54 TYP	
e	1.27 TYP	
L	13.97	14.97

UNIT: mm

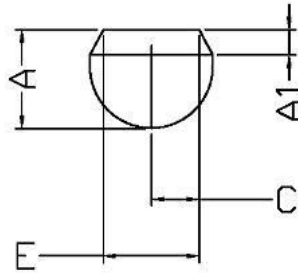

SOT-233

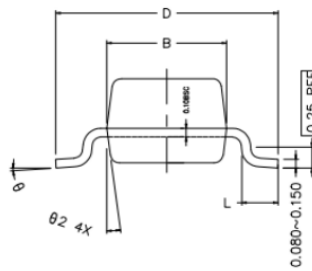
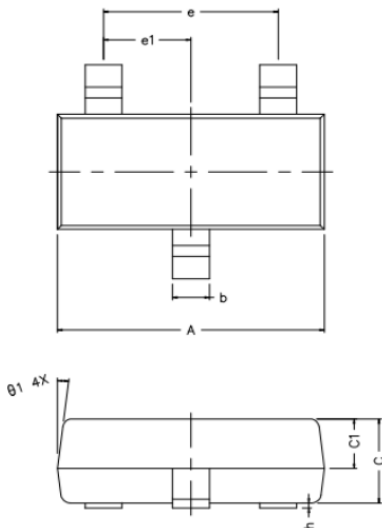

COMMON DIMENSIONS (UNITS OF MEASURE IS mm)			
	MIN	NORMAL	MAX
A	2.800	2.900	3.100
B	1.200	1.300	1.400
C	0.800	0.900	1.000
C1	0.500	0.550	0.600
D	2.250	2.400	2.550
L	0.300	0.400	0.500
h	0.005	0.050	0.100
b	0.300	0.400	0.500
e	1.90 TYPE		
e1	0.95 TYPE		
θ ₁	7° TYPE		
θ ₂	7° TYPE		
θ	0° ~ 7°		

[if you need helpcontact us. Xinluda reserves the right to changethe above information withoutpriornotice]