



PJMD60H12TNSA

N-Channel Depletion Mode MOSFET

Product Summary

- $V_{DS} = 600V, I_D = 0.03A$
- $R_{DS(on)} < 120\Omega @ V_{GS} = 10V$
- $R_{DS(on)} < 160\Omega @ V_{GS} = 0V$

Features

- Advanced Planar Technology
- ESD Improved Capability
- RoHS and Reach Compliant
- Halogen and Antimony Free
- Moisture Sensitivity Level 1

SOT-23

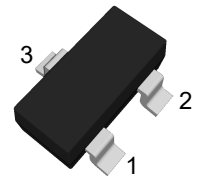

(Top View)

Pin	Description
1	Gate
2	Source
3	Drain

Marking Code

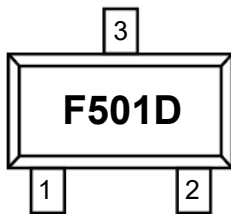

Schematic Diagram

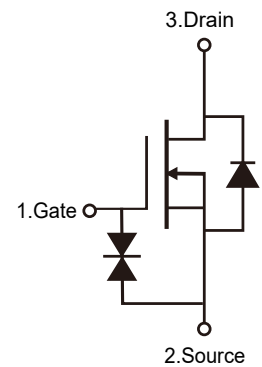

Absolute Maximum Ratings

Ratings at 25°C ambient temperature unless otherwise specified.

Parameter	Symbol	Value	Unit
Drain-Source Voltage	V_{DS}	600	V
Gate-Source Voltage	V_{GS}	± 20	V
Drain Current-Continuous	I_D	$T_A = 25^\circ C$	0.03
		$T_A = 70^\circ C$	0.24
Drain Current-Pulsed ^{Note1}	I_{DM}	0.12	A
Maximum Power Dissipation	P_D	0.5	W
Gate Source ESD (HBM-C=100pF, R=1.5k Ω)	$V_{ESD(G-S)}$	300	V
Junction and Storage Temperature Range	T_J, T_{STG}	-55 to +150	$^\circ C$

Thermal Characteristics

Thermal Resistance, Junction-to-Ambient	$R_{\theta JA}$	250	$^\circ C/W$
---	-----------------	-----	--------------



PJMD60H12TNSA

N-Channel Depletion Mode MOSFET

Electrical Characteristics

(Ta=25°C unless otherwise specified)

Parameter	Symbol	Test Condition	Min.	Typ.	Max.	Unit
OFF Characteristics						
Drain-Source Breakdown Voltage	$V_{(BR)DSS}$	$V_{GS}=-5V, I_D=250\mu A$	600	--	--	V
Gate-Body Leakage Current	$I_{D(off)}$	$V_{DS}=600V, V_{GS}=-5V$	--	--	0.1	μA
		$V_{DS}=480V, V_{GS}=-5V, T_A=125^\circ C$	--	--	10	μA
Gate Leakage Current	I_{GSS}	$V_{GS}=\pm 20V$	--	--	± 200	nA
ON Characteristics						
Gate-to-Source Cut-off Voltage ^{Note2}	V_P	$V_{DS}=3V, I_D=8\mu A$	-3	-2.5	-1	V
On-State Drain Current ^{Note2}	$I_{DS(on)}$	$V_{GS}=0V, V_{DS}=25V$	12	--	--	mA
Drain-Source On-Resistance ^{Note2}	$R_{DS(on)}$	$V_{GS}=0V, I_D=3mA$	--	117	160	Ω
		$V_{GS}=10V, I_D=16mA$	--	87	120	Ω
Dynamic Characteristics						
Forward Transconductance ^{Note2}	g_{FS}	$V_{DS}=30V, I_D=0.01A$	--	12	--	mS
Input Capacitance	C_{iss}	$V_{DS}=25V, V_{GS}=-5V, f=1MHz$	--	24	--	pF
Output Capacitance	C_{oss}		--	6.5	--	pF
Reverse Transfer Capacitance	C_{rss}		--	4	--	pF
Total Gate Charge	Q_g	$V_{DD}=400V, I_D=0.01A, V_{GS}=-5V\sim 5V$	--	1.14	--	nC
Gate-Source Charge	Q_{gs}		--	0.5	--	nC
Gate-Drain Charge	Q_{gd}		--	0.37	--	nC
Switching Characteristics						
Turn-on Delay Time	$t_{d(on)}$	$V_{DD}=300V, I_D=0.01A, V_{GS}=-5V\sim 7V, R_G=6\Omega$	--	9.9	--	nS
Turn-on Rise Time	t_r		--	55.8	--	nS
Turn-off Delay Time	$t_{d(off)}$		--	56.4	--	nS
Turn-off Fall Time	t_f		--	136	--	nS
Drain-Source Diode Characteristics						
Diode Forward Voltage ^{Note2}	V_{SD}	$V_{GS}=-5V, I_F=16mA$	--	--	1.2	V
Diode Forward Current	I_S		--	--	0.03	A
Gate-Source Zener Diode						
Gate-Source Breakdown Voltage ^{Note3}	V_{GSO}	$I_{GS}=\pm 1mA$ (Open Drain)	20	--	--	V

Note: 1. Repetitive Rating: Pulse width limited by maximum junction temperature

2. Pulse Test: Pulse width $\leq 300\mu s$, duty cycle $\leq 2\%$.

3. The built-in back-to-back Zener diodes have specifically been designed to enhance not only the device's ESD capability, but also to make them safely absorb possible voltage transients that may occasionally be applied from gate to source. In this respect the Zener voltage is appropriate to achieve an efficient and cost-effective intervention to protect the device's integrity. These integrated Zener diodes thus avoid the usage of external components.



PJMD60H12TNSA

N-Channel Depletion Mode MOSFET

Typical Characteristic Curves

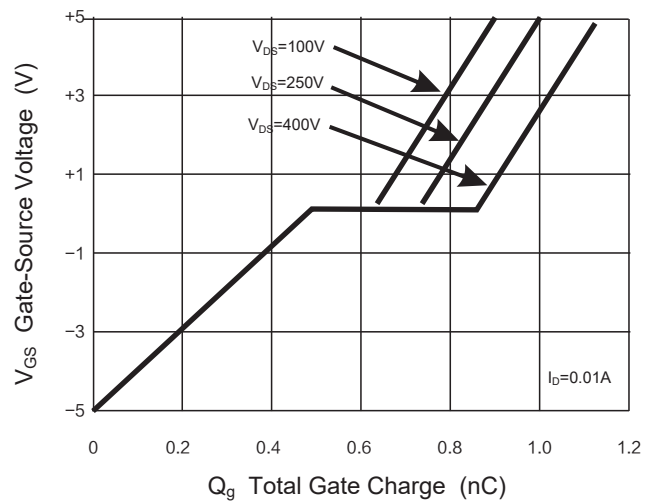
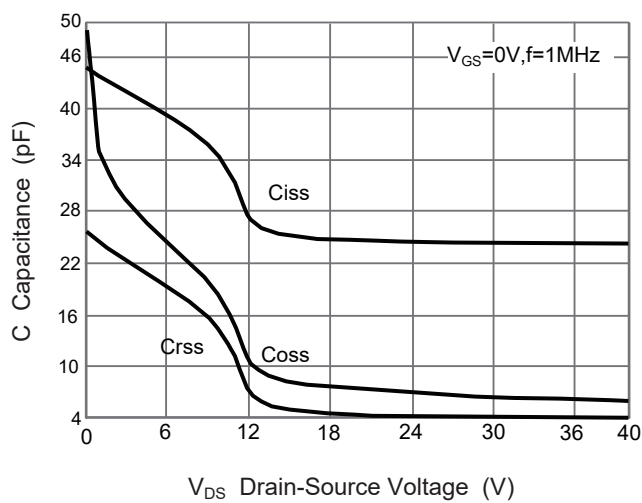
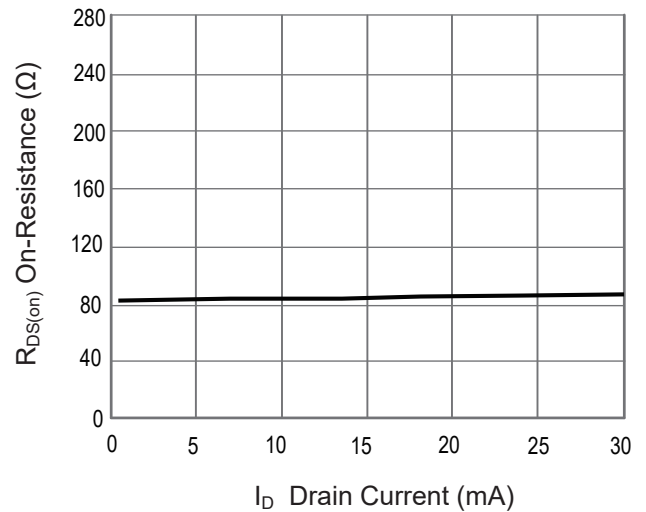
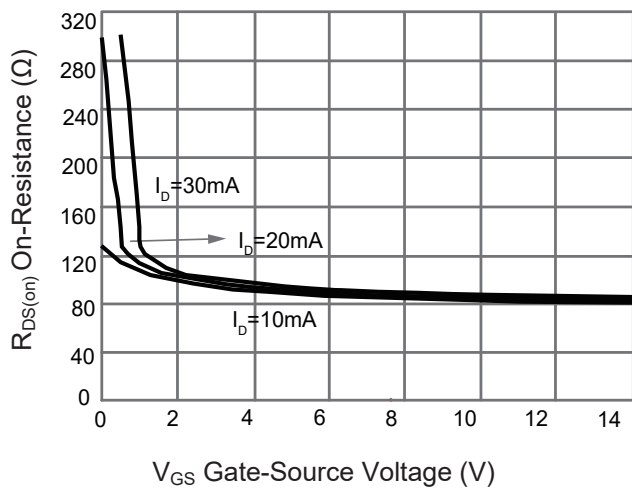
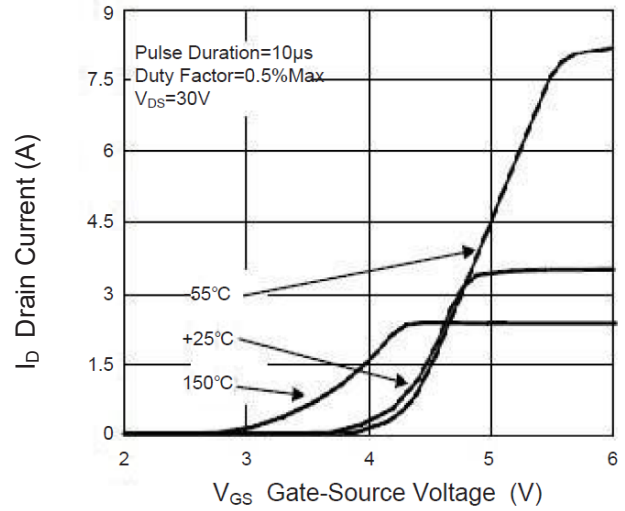
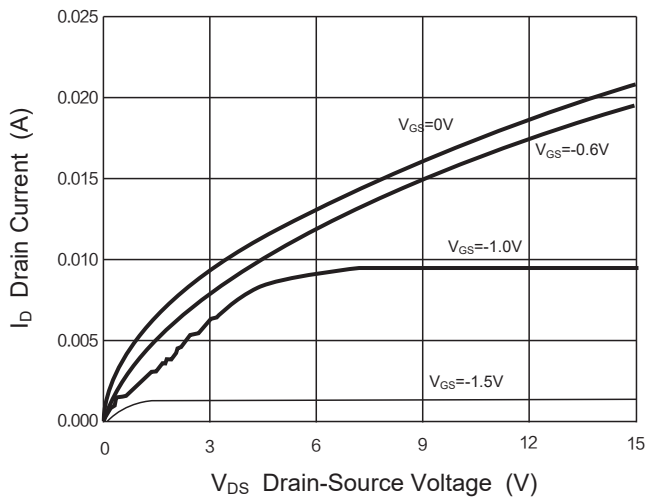



PJMD60H12TNSA

N-Channel Depletion Mode MOSFET

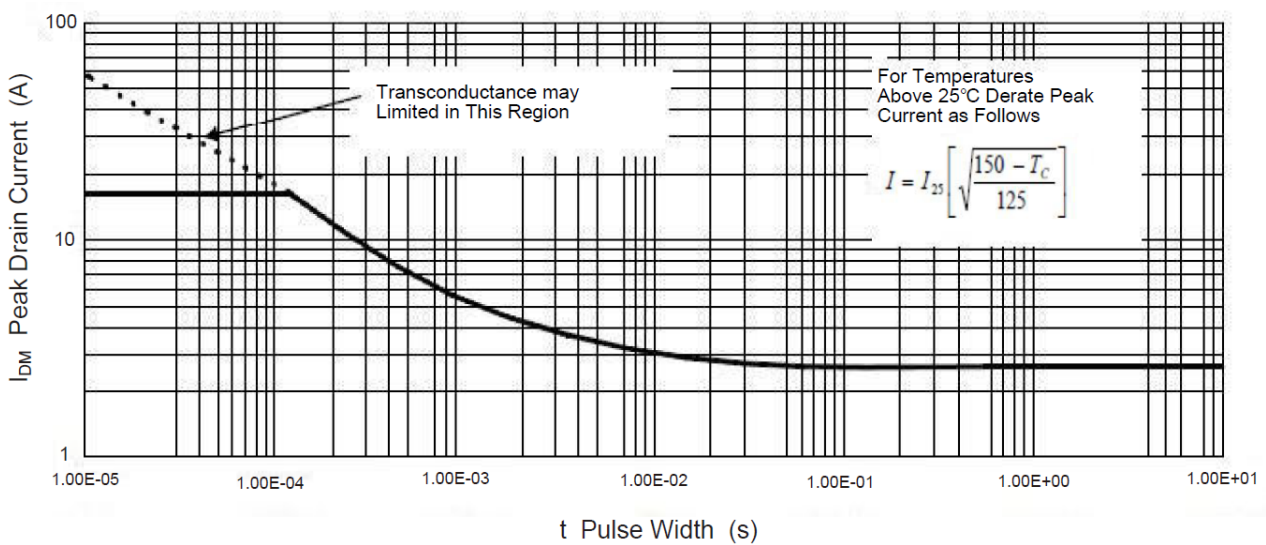
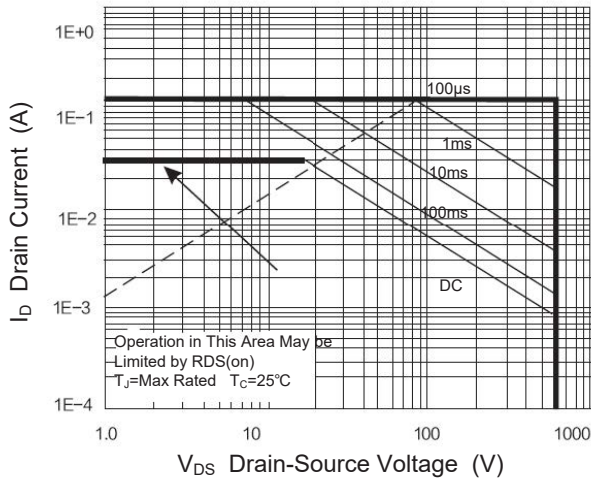
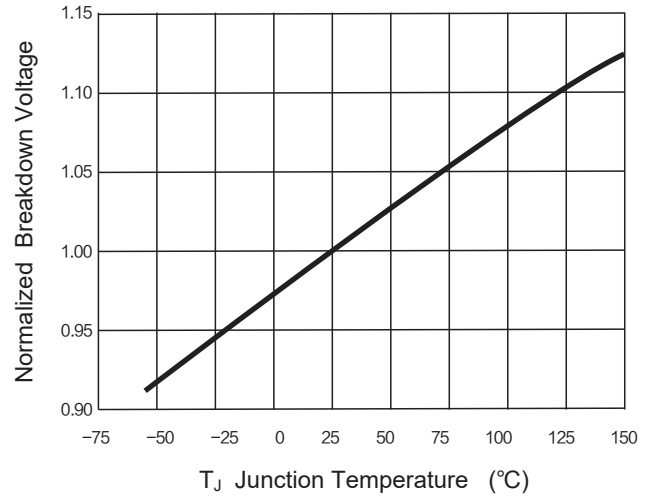
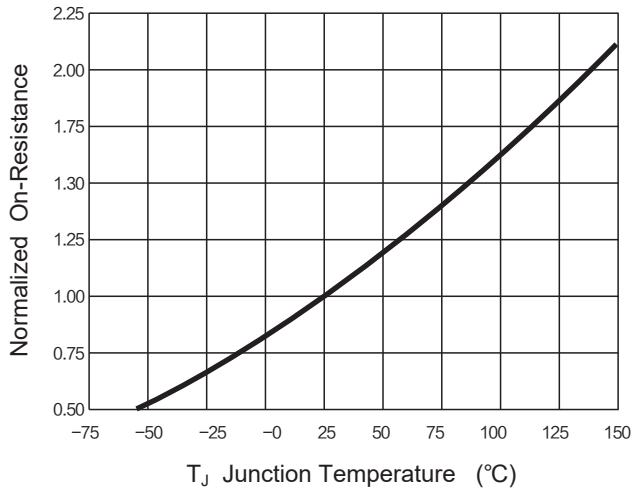



PJMD60H12TNSA

N-Channel Depletion Mode MOSFET

Package Outline

SOT-23

Dimensions in mm

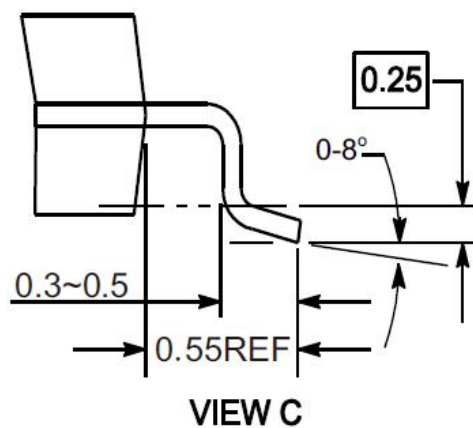
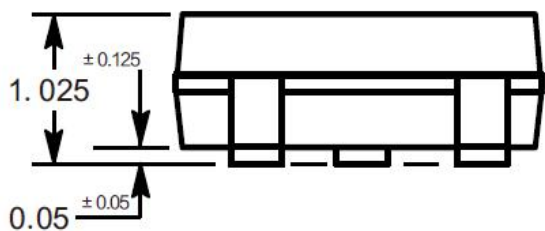
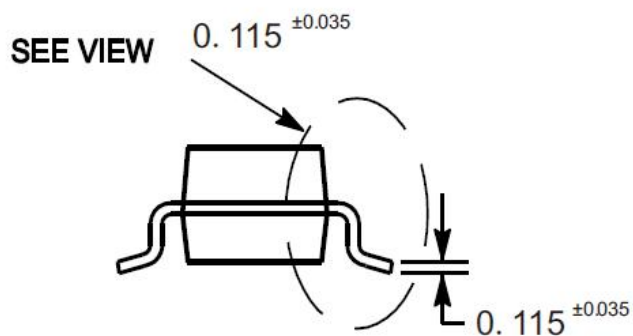
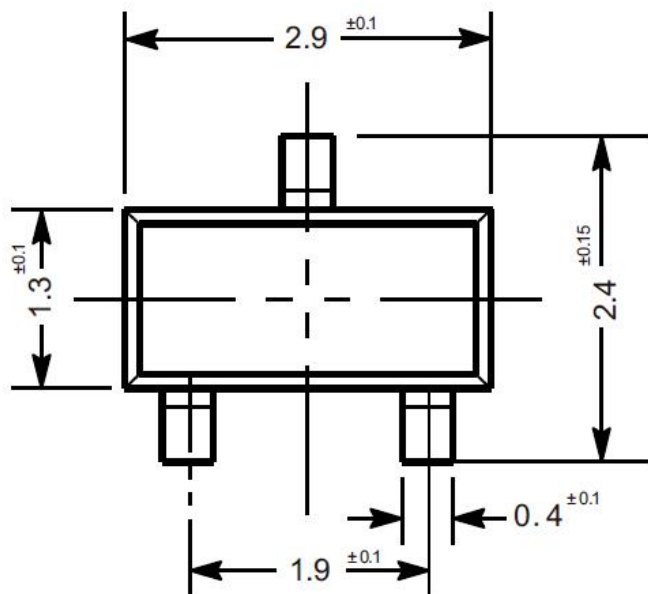

Ordering Information

Device	Package	Shipping
PJMD60H12TNSA	SOT-23	3,000PCS/Reel&7inches



Conditions of Soldering and Storage

◆ Recommended condition of Reflow Soldering(Pb-Free Solder)

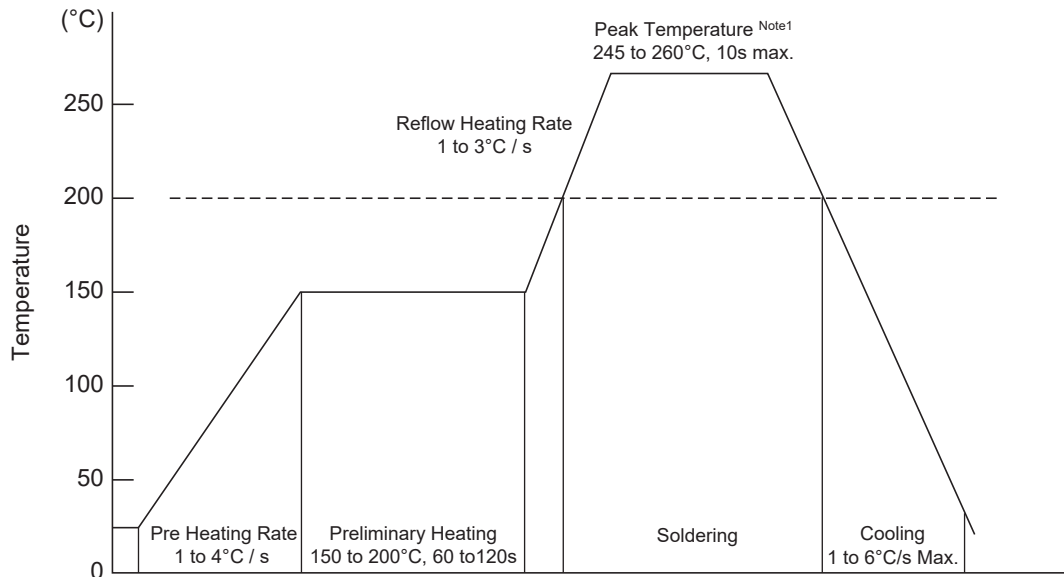

Recommended peak temperature is over 245°C. If peak temperature is below 245°C, you may adjust the following parameters:

- Time length of peak temperature (longer)
- Time length of soldering (longer)
- Thickness of solder paste (thicker)

Note1:

Maximum thermal excursion allowed during the reflow assembly is as follow:

- Temperature: 255°C~260°C
- Duration at peak soak : 30 seconds
- Number of reflow: 3
- **Conditions of hand soldering** Note2

- Temperature: 320±10°C
- Time: 3s max.
- Times: one time

Note2: Not recommended for mass production, an engineering project, or re-work, it is allowed. It should be used with caution

● **Storage conditions**

● **Temperature**

5 to 30°C

● **Humidity**

≤ 60% RH

● **Floor Life**

No Limited

● **Recommended period**

Five year after manufacturing(Depends on storage conditions)



PJMD60H12TNSA

N-Channel Depletion Mode MOSFET

Package Specifications

- The method of packaging

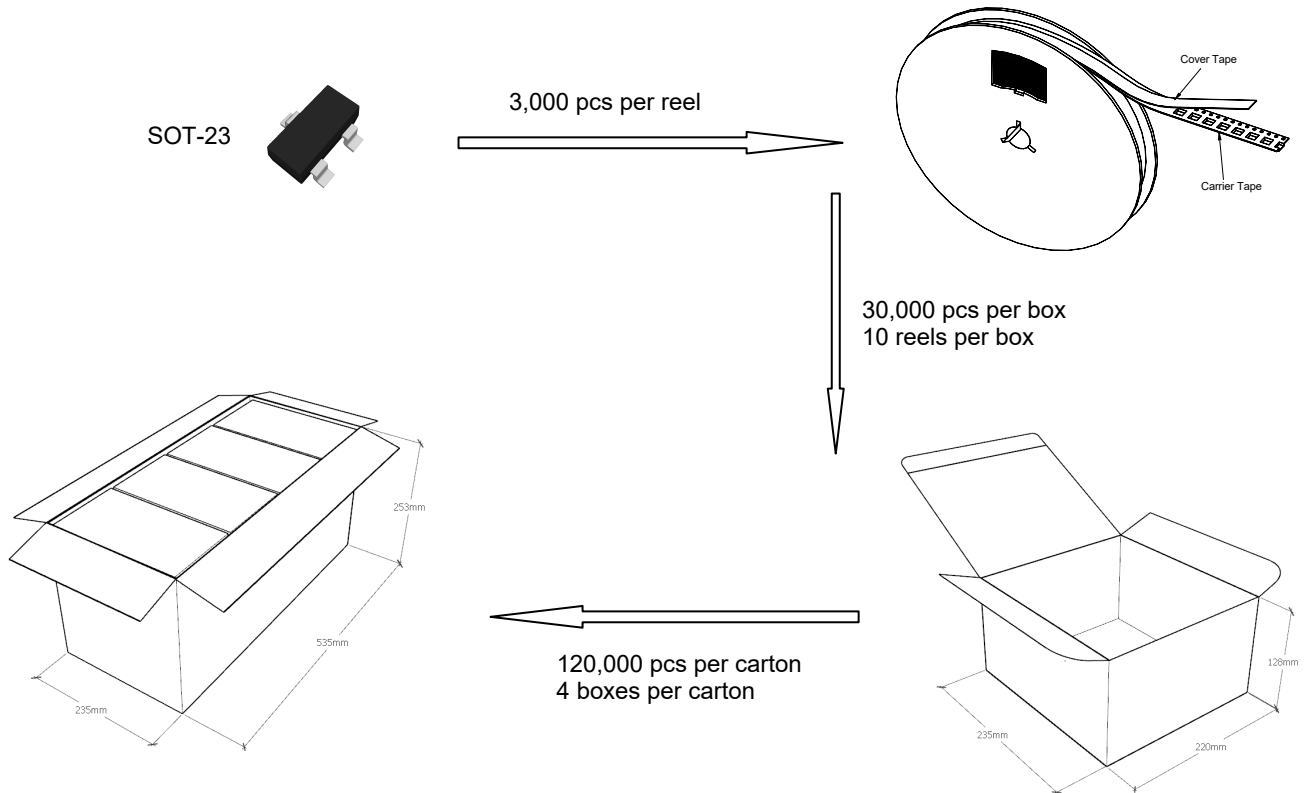

◆ Embossed tape and reel data

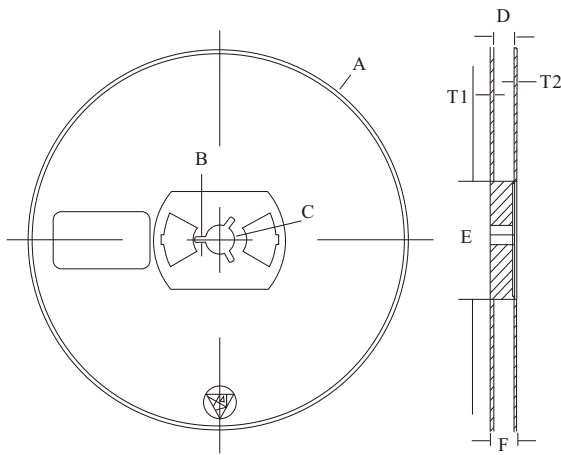

Symbol	Value (unit: mm)
A	Ø 177.8±1
B	2.7±0.2
C	Ø 13.5±0.2
E	Ø 54.5±0.2
F	12.3±0.3
D	9.6+2/-0.3
T1	1.0±0.2
T2	1.2±0.2

Reel (7")

