

RECOMMEND P.C.B LAYOUT
TOLERANCE UNSPECIFIED ±0.05mm

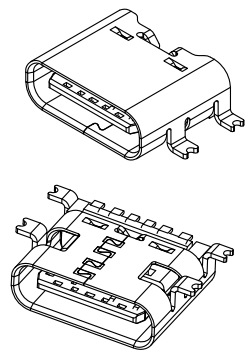

- NOTES:
SPECIFICATION:
1.CURRENT RATING: 3.0A MAX
2.VOLTAGE: 100 VAC
3.TEMPERATURE RANGE: -30°C~+85°C
4.CONTACT RESISTANCE: 40 MILLIONHM MAX
5.INSULATION RESISTANCE: 100 MEGOHMS MIN
6.LNSERTION FORCE: 5N~20N
7.UNMATING FORCE: 8N~20N
8.DURABILITY: 10000 CYCLES

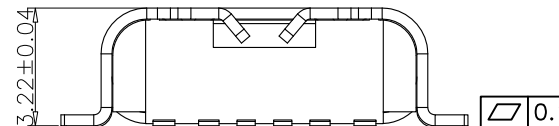
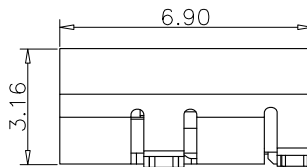
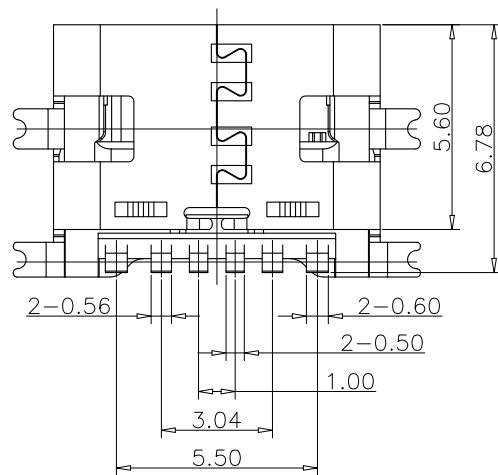
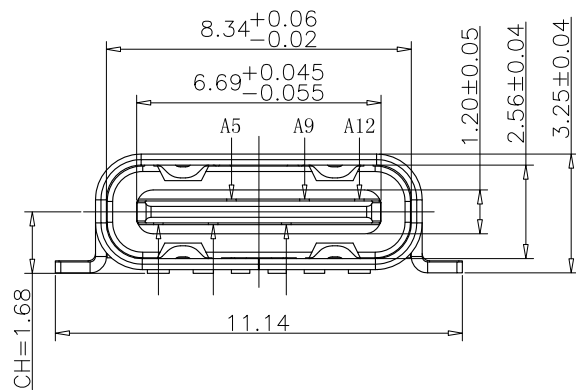

USB TYPE C PIN ASSIGNMENTS

PIN NUMBER	SIGNAL NAME	PIN NUMBER	SIGNAL NAME
A5	CC1	B12	GND
A9	VBUS	B9	VBUS
A12	GND	B5	CC2

TABLE:

NO	PART	Q'TY	Material
1	SHELL	1	STAINLESS STEEL,NI PLATED
2	CONTACT	6	COPPER STEEL,TIN/Au/NI PLATED
3	HOUSING	1	HIGH TEMPERATURE RESISTANT PLASTIC BLACK UL94 V-0

YWF 深圳市宇文发电子科技有限公司
Shen Zhen Yu Wen Fa Electronics Technology Co.,Ltd
TEL:0755-27711235 FAX:0755-27712683

品名 (ITEM NO)	TYPE CF 6P单排 SMT CONN(全贴)
料号 (PART NO)	PTCFW-H21A-002
图号 (DWG NO)	P-TCF-109

页码 (SHEET)	1/1	单位(UNIT): MM
版本 (REV)	A0	比例(SCALE) 1:1
日期 (DATE)	2022.09.20	未注公差 TOLERANCE UNSPECIFIED
设计 (DESIGN)	YUXIANG	X.X ±0.30
审核 (CHECKED)		X.XX ±0.20
核准 (APPROVED)		X.XXX ±0.10
		X° ±5°
		X.X° ±2°

RoHS Compliant

备注: 1. 每盘装1200PCS,并贴上3PCS美纹胶,然后贴上对应的产品标签。
 2. 外箱底部先垫一隔板,并在外箱四个内角各放置一个三角架,把9卷(10800PCS)封装好的产品标签一律朝上平放进外箱中上层盖上一隔板,再用封箱胶纸将外箱口于“工”字型封好。

REV.	ECN NO	DESCRIPTION	REVISER	DATE
A/0				
A/1				

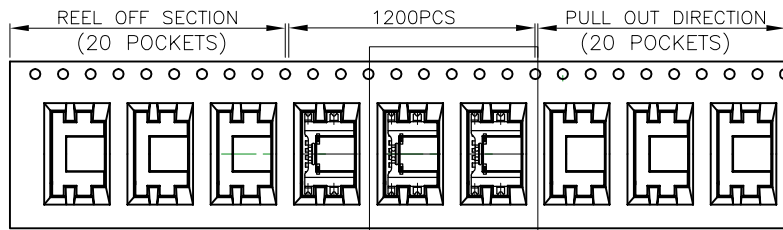

SEE DETAIL X

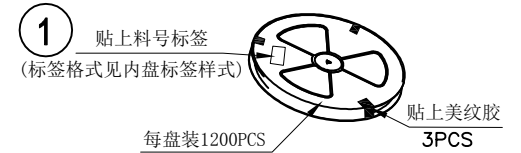
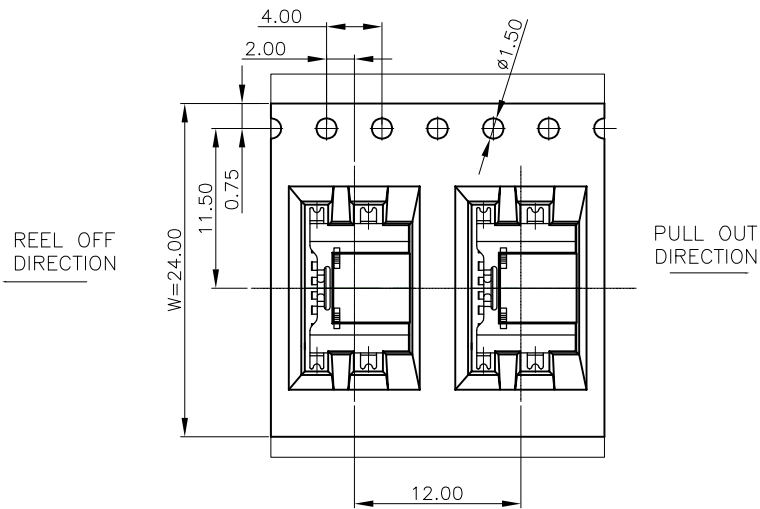
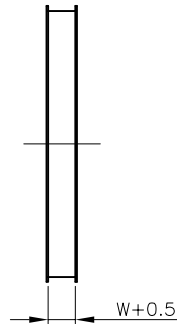
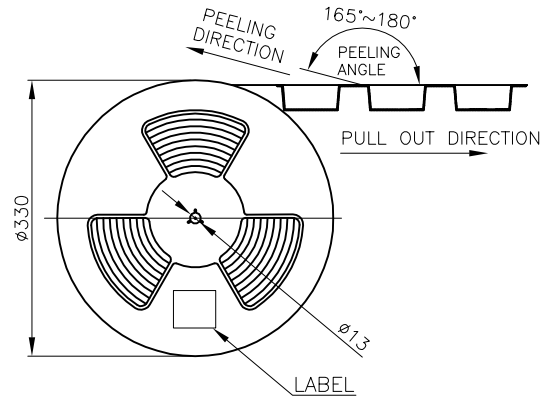

每盘装1200PCS,并贴上3PCS美纹胶,然后贴上标签

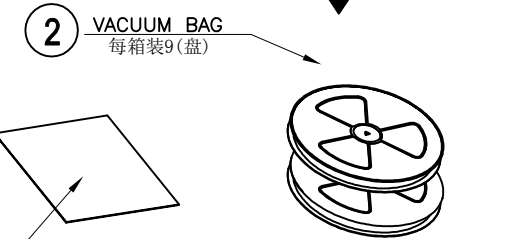

2PCS 隔板
上下各放一块隔板

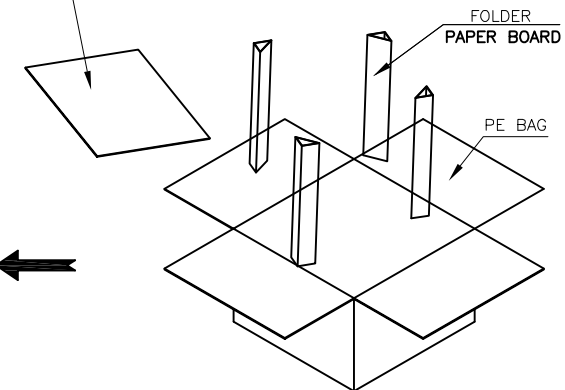
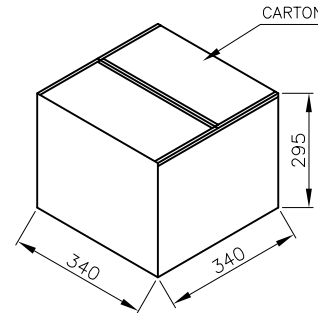

	REEL	CARTON
CONNECTOR (PCS)	1200	10800

图号 (DWG NO)		单位 (UNIT): MM	深圳市宇文发电子科技有限公司 Shen Zhen Yu Wen Fa Electronics Technology Co., Ltd TEL:0755-27711235 FAX:0755-27712683	
日期 (DATE)	2021. 12. 10	比例 (SCALE) 1:1		
版次 (REV): A/0	页/次(PAGE): 1/1			
设计 (DESIGN)	ZHUANG	包装规范	品名 (ITEM NO)	TYPE C 母座 6P全贴 包装规范
审核 (CHECKED)			料号 (PART NO)	A-004R-112普通包装
核准 (APPROVED)				