

Features

- Up to 2 lines protects
- Junction capacitance (Max value:75pF)
- Peak Pulse current (8/20 μ s) MAX: 13A
- IEC61000-4-2 (ESD) \pm 20kV (air), \pm 15kV (contact)
- Low leakage current
- Working voltages:7V or 12V
- RoHS Compliant

Mechanical Characteristics

- Package: SOT-23
- Lead Finish: Matte Tin
- Case Material: "Green" Molding Compound.
- UL Flammability Classification Rating 94V-0
- Moisture Sensitivity: Level 3 per J-STD-020
- Tape Reel :3000pcs

Appearance & Symbol

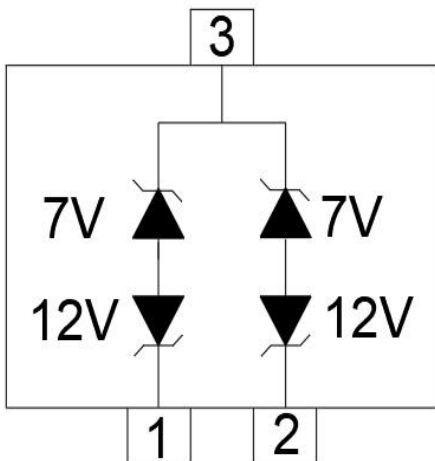
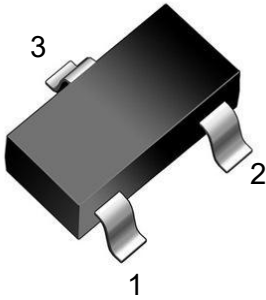

Applications

- Wireless System
- Networks
- Portable Instrumentation
- RS485 Ports

Marking Information

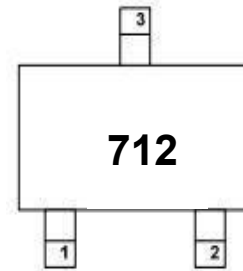

712=Marking Code

Absolute Maximum Ratings (T=25°C, RH=45%-75%, unless otherwise noted)

Parameter	Symbol	Value	Unit
Peak Pulse Power (8/20µs)	P _{pp}	325	W
Peak Pulse Current (8/20µs)	I _{pp}	13	A
ESD per IEC 61000-4-2 (Air)	V _{ESD}	±20	kV
ESD per IEC 61000-4-2 (Contact)		±15	
Operating Temperature Range	T _J	-55 to +125	°C
Storage Temperature Range	T _{stg}	-55 to +150	°C

Electrical Characteristics (T=25°C, RH=45%-75%, unless otherwise noted)

Parameter	Symbol	Pin 1 or Pin 2 to Pin 3 (12V)			Pin 3 to Pin 1 or Pin 2 (7V)			Unit	Test Condition
		Min	Typ	Max	Min	Typ	Max		
Reverse Working Voltage	V _{RWM}			12			7	V	
Breakdown Voltage	V _{BR}	13.3			7.5			V	I _T = 1mA
Reverse Leakage Current	I _R			0.05			2.0	µA	V _R = V _{RWM}
Clamping Voltage	V _C			20			10	V	I _{PP} = 5A (8 x 20µs pulse)
Clamping Voltage	V _C			26			16	V	I _{PP} = 13A (8 x 20µs pulse)
Junction Capacitance	C _J			75			75	pF	V _R = 0V, f = 1MHz
Junction Capacitance	C _J		45			45		pF	V _R = V _{RWM} , f = 1MHz

Typical Performance Characteristics (T_A=25°C unless otherwise Specified)

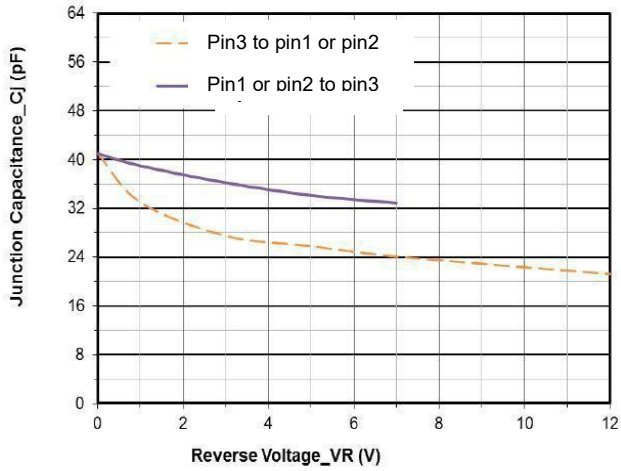

Junction Capacitance vs. Reverse Voltage

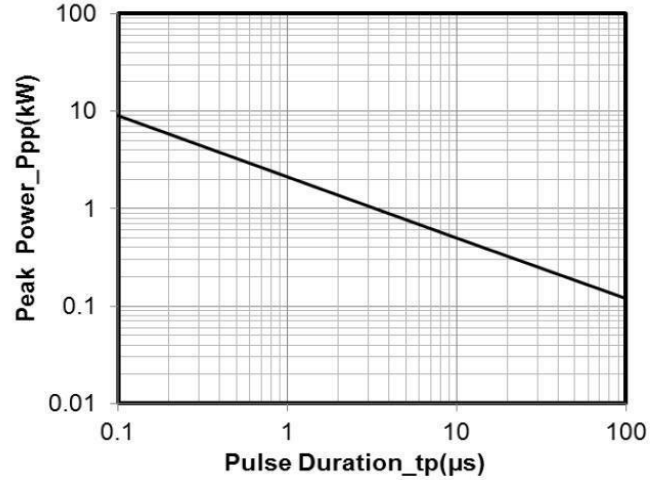

Peak Pulse Power vs. Pulse Time

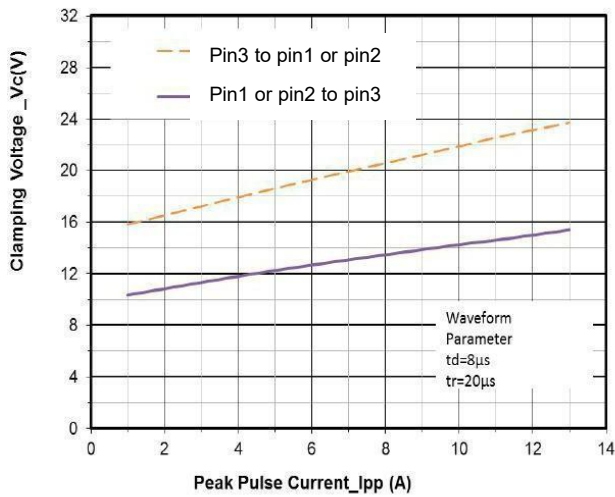

Clamping Voltage vs. Peak Pulse Current

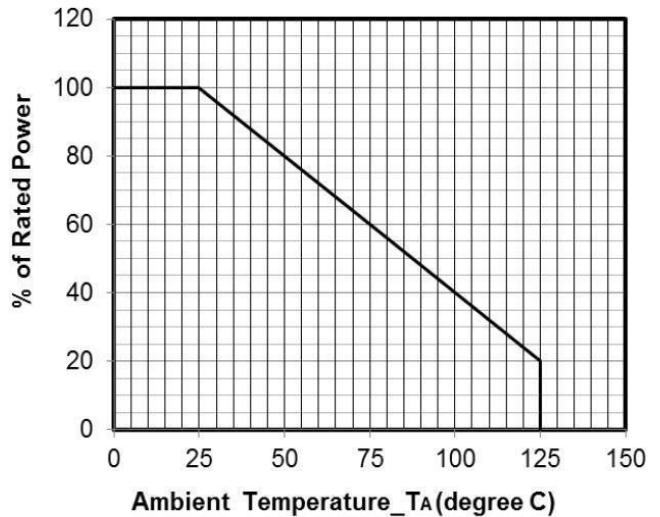

Power Derating Curve

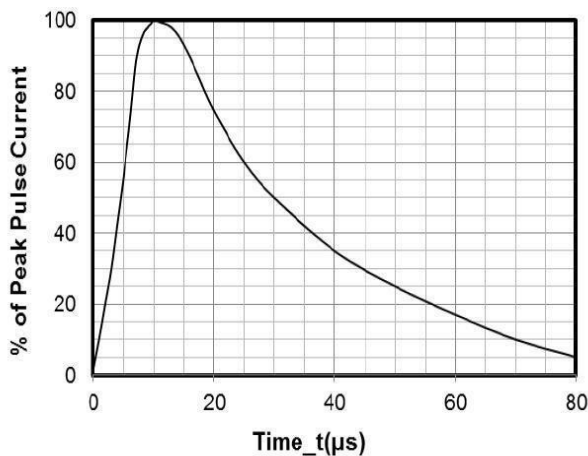

8 X 20μs Pulse Waveform

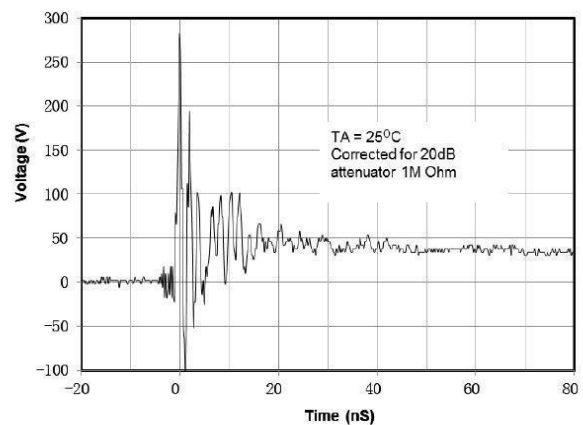

ESD Clamping Voltage
8 kV Contact per IEC61000-4-2

Soldering parameters

Reflow Condition		Pb-Free assembly (see as bellow)
Pre Heat	-Temperature Min ($T_{s(min)}$)	+150°C
	-Temperature Max($T_{s(max)}$)	+200°C
	-Time (Min to Max) (t_s)	60-180 secs.
Average ramp up rate (Liquid us Temp (T_L) to peak)		3°C/sec. Max
$T_{s(max)}$ to T_L - Ramp-up Rate		3°C/sec. Max
Reflow	-Temperature(T_L) (Liquid us)	+217°C
	-Temperature(t_L)	60-150 secs.
Peak Temp (T_p)		+260(+0/-5)°C
Time within 5°C of actual Peak Temp (t_p)		30 secs. Max
Ramp-down Rate		6°C/sec. Max
Time 25°C to Peak Temp (T_p)		8 min. Max
Do not exceed		+260°C

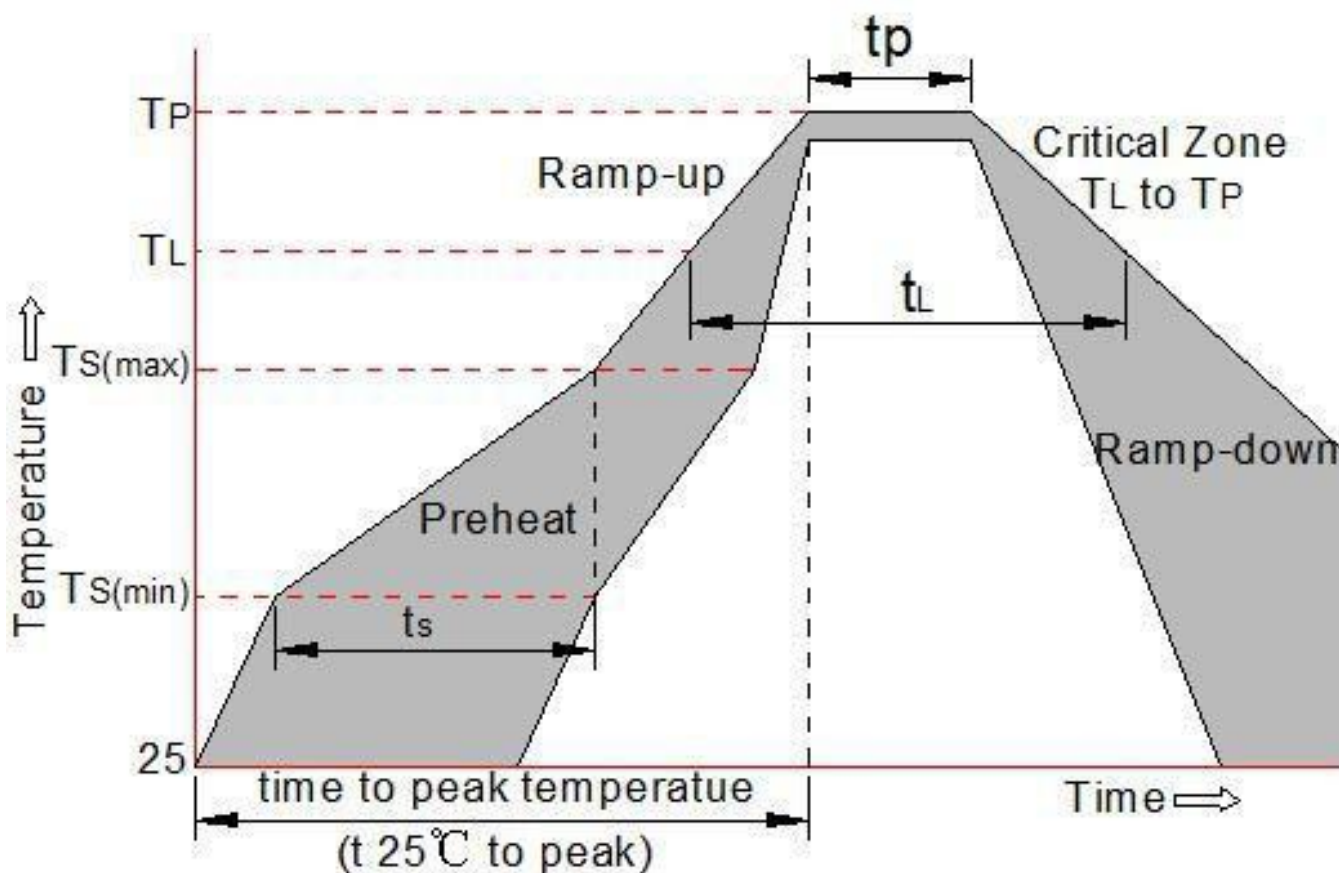

Package mechanical data

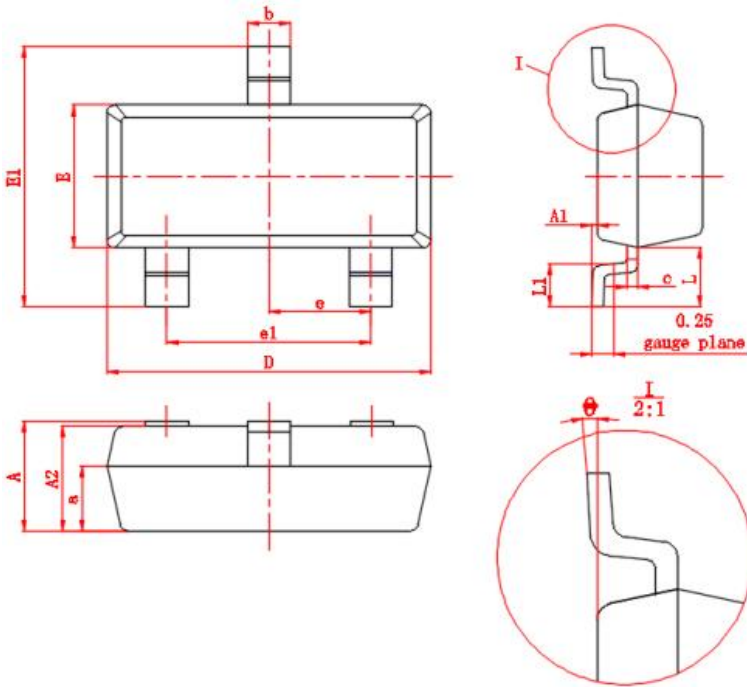

Symbol	Dimensional Millimeters	
	min	max
A	0.9	1.15
A1	0	0.1
A2	0.9	1.05
a	(0.6)	
D	2.8	3.0
E	1.2	1.4
E1	2.25	2.55
e	(0.95)	
e1	1.8	2.0
b	0.3	0.5
c	0.08	0.15
L	(0.55)	
L1	0.3	0.5
θ	0°	8°

Suggested Land Pattern

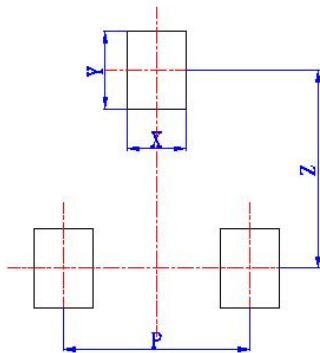

Symbol	Dimensional Millimeters	
	X	(0.6)
Y	(0.8)	
Z	(2.02)	
P	(1.9)	