

Digital temperature sensor and thermal watchdog

1. General description

The LM75BD,118 is a temperature-to-digital converter using an on-chip band gap temperature sensor and Sigma-Delta A-to-D conversion technique with an over temperature detection output. The LM75BD,118 contains a number of data registers: Configuration register (Conf) to store the device settings such as device operation mode, OS operation mode, OS polarity and OS fault queue as described in [Section 7 “Functional description”](#); temperature register (Temp) to store the digital temp reading, and set-point registers (Tos and Thyst) to store programmable over temperature shutdown and hysteresis limits, that can be communicated by a controller via the 2-wire serial I²C-bus interface. The device also includes an open-drain output (OS) which becomes active when the temperature exceeds the programmed limits. There are three selectable logic address pins so that eight devices can be connected on the same bus without address conflict.

The LM75BD,118 can be configured for different operation conditions. It can be set in normal mode to periodically monitor the ambient temperature, or in shutdown mode to minimize power consumption. The OS output operates in either of two selectable modes: OS comparator mode or OS interrupt mode. Its active state can be selected as either HIGH or LOW. The fault queue that defines the number of consecutive faults in order to activate the OS output is programmable as well as the set-point limits.

The temperature register always stores an 11-bit two's complement data giving a temperature resolution of 0.125 °C. This high temperature resolution is particularly useful in applications of measuring precisely the thermal drift or runaway. When the LM75BD,118 is accessed the conversion in process is not interrupted (that is, the I²C-bus section is totally independent of the Sigma-Delta converter section) and accessing the LM75BD,118 continuously without waiting at least one conversion time between communications will not prevent the device from updating the Temp register with a new conversion result. The new conversion result will be available immediately after the Temp register is updated.

The LM75BD,118 powers up in the normal operation mode with the OS in comparator mode, temperature threshold of 80 °C and hysteresis of 75 °C, so that it can be used as a stand-alone thermostat with those pre-defined temperature set points.

2. Features

- Pin-for-pin replacement for industry standard XX75 and XX75A and offers improved temperature resolution of 0.125 °C and specification of a single part over power supply range from 2.8 V to 5.5 V
- I²C-bus interface with up to 8 devices on the same bus
- Power supply range from 2.8 V to 5.5 V
- Temperatures range from –55° C to +125 °C
- Frequency range 20 Hz to 400 kHz with bus fault time-out to prevent hanging up the bus
- 11-bit ADC that offers a temperature resolution of 0.125 °C
- Temperature accuracy of:
 - ±0.5 °C from 0°C to +50 °C
 - ±1 °C from –25° C to +100 °C
 - ±1.5 °C from –55° C to +125 °C

- Programmable temperature threshold and hysteresis set points
- Supply current of 1.0 μ A in shutdown mode for power conservation
- Stand-alone operation as thermostat at power-up
- ESD protection exceeds 4500 V HBM per JESD22-A114 and 1 000 V CDM per JESD22-C101
- Latch-up testing is done to JEDEC Standard JESD78 which exceeds 100 mA
- Small 8-pin package types: MSOP8, TSSOP8

3. Applications

- System thermal management
- Personal computers
- Electronics equipment
- Industrial controllers

4. Ordering information

Table 1. Ordering information

PART NUMBER	PACKAGE	SPQ
LM75BD,118	SOP8	4000

5. Block diagram

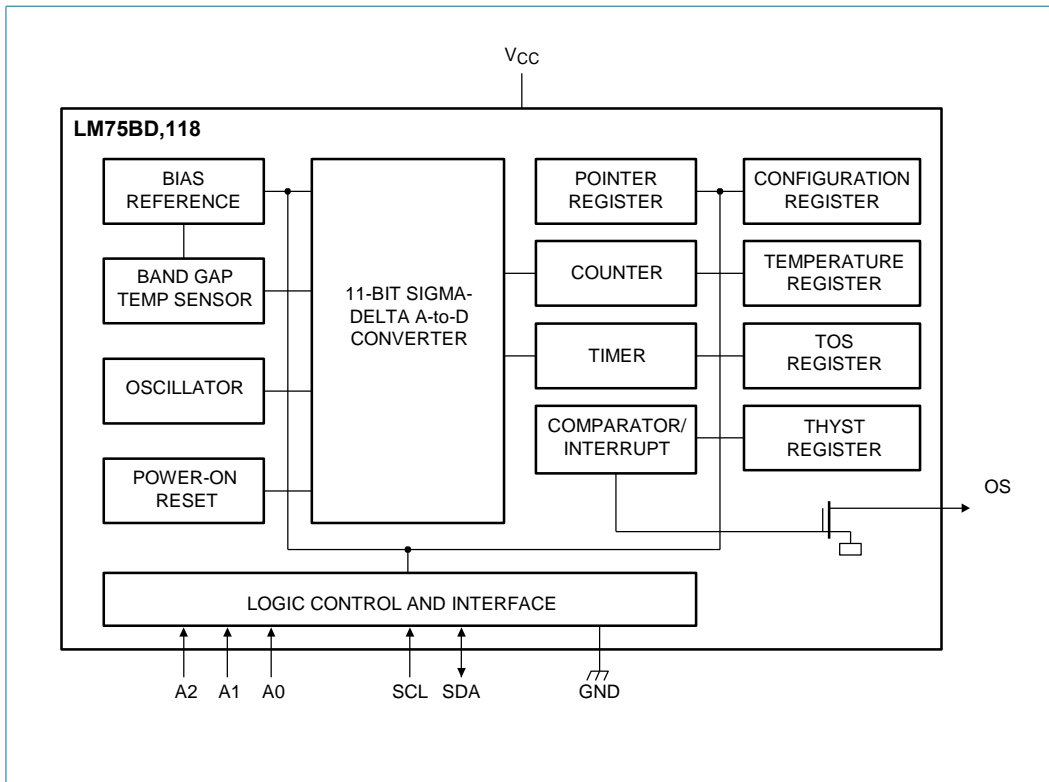
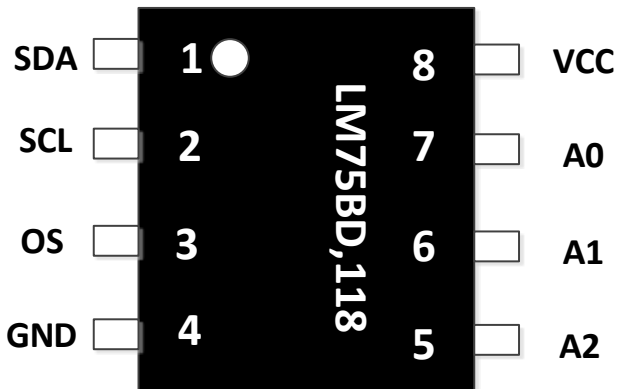

Fig 1. Block diagram of LM75BD,118

6. Pinning information

6.1 Pinning



SOP8 Package

6.2 Pin description

Table 3. Pin description

Symbol	Pin	Description
SDA	1	Digital I/O. I ² C-bus serial bidirectional data line; open-drain.
SCL	2	Digital input. I ² C-bus serial clock input.
OS	3	Overtemperature Shutdown output; open-drain.
GND	4	Ground. To be connected to the system ground.
A2	5	Digital input. User-defined address bit 2.
A1	6	Digital input. User-defined address bit 1.
A0	7	Digital input. User-defined address bit 0.
V _{CC}	8	Power supply.

7. Functional description

7.1 General operation

The LM75BD,118 uses the on-chip band gap sensor to measure the device temperature with the resolution of 0.125 °C and stores the 11-bit two's complement digital data, resulted from 11-bit A-to-D conversion, into the device Temp register. This Temp register can be read at any time by a controller on the I²C-bus. Reading temperature data does not affect the conversion in progress during the read operation.

The device can be set to operate in either mode: normal or shutdown. In normal operation mode, the temp-to-digital conversion is executed every 100 ms and the Temp register is updated at the end of each conversion. During each 'conversion period' (T_{conv}) of about 100 ms the device takes only about 10 ms, called 'temperature conversion time' ($t_{conv(T)}$), to complete a temperature-to-data conversion and then becomes idle for the time remaining in the period. This feature is implemented to significantly reduce the device power dissipation. In shutdown mode, the device becomes idle, data conversion is disabled and the Temp register holds the latest result; however, the device I²C-bus interface is still active and register write/read operation can be performed. The device operation mode is controllable by programming bit B0 of the configuration register. The temperature conversion is initiated when the device is powered-up or put back into normal mode from shutdown.

In addition, at the end of each conversion in normal mode, the temperature data (or Temp) in the Temp register is automatically compared with the over temperature shutdown threshold data (or $T_{th(ots)}$) stored in the Tos register, and the hysteresis data (or T_{hys}) stored in the Thyst register, in order to set the state of the device OS output accordingly. The device Tos and Thyst registers are write/read capable, and both operate with 9-bit two's complement digital data. To match with this 9-bit operation, the Temp register uses only the 9 MSB bits of its 11-bit data for the comparison.

The way that the OS output responds to the comparison operation depends upon the OS operation mode selected by configuration bit B1, and the user-defined fault queue defined by configuration bits B3 and B4.

In OS comparator mode, the OS output behaves like a thermostat. It becomes active when the Temp exceeds the $T_{th(ots)}$, and is reset when the Temp drops below the T_{hys} . Reading the device registers or putting the device into shutdown does not change the state of the OS output. The OS output in this case can be used to control cooling fans or thermal switches.

In OS interrupt mode, the OS output is used for thermal interruption. When the device is powered-up, the OS output is first activated only when the Temp exceeds the $T_{th(ots)}$; then it remains active indefinitely until being reset by a read of any register. Once the OS output has been activated by crossing $T_{th(ots)}$ and then reset, it can be activated again only when the Temp drops below the T_{hys} ; then again, it remains active indefinitely until being reset by a read of any register. The OS interrupt operation would be continued in this sequence: $T_{th(ots)}$ trip, Reset, T_{hys} trip, Reset, $T_{th(ots)}$ trip, Reset, T_{hys} trip, Reset, etc. Putting the device into the shutdown mode by setting the bit 0 of the configuration register also resets the OS output.

In both cases, comparator mode and interrupt mode, the OS output is activated only if a number of consecutive faults, defined by the device fault queue, has been met. The fault queue is programmable and stored in the two bits, B3 and B4, of the Configuration register. Also, the OS output active state is selectable as HIGH or LOW by setting accordingly the configuration register bit B2.

At power-up, the device is put into normal operation mode, the $T_{th(ots)}$ is set to 80 °C, the T_{hys} is set to 75 °C, the OS active state is selected LOW and the fault queue is equal to 1. The temp reading data is not available until the first conversion is completed in about 100 ms.

The OS response to the temperature is illustrated in [Figure 6](#).

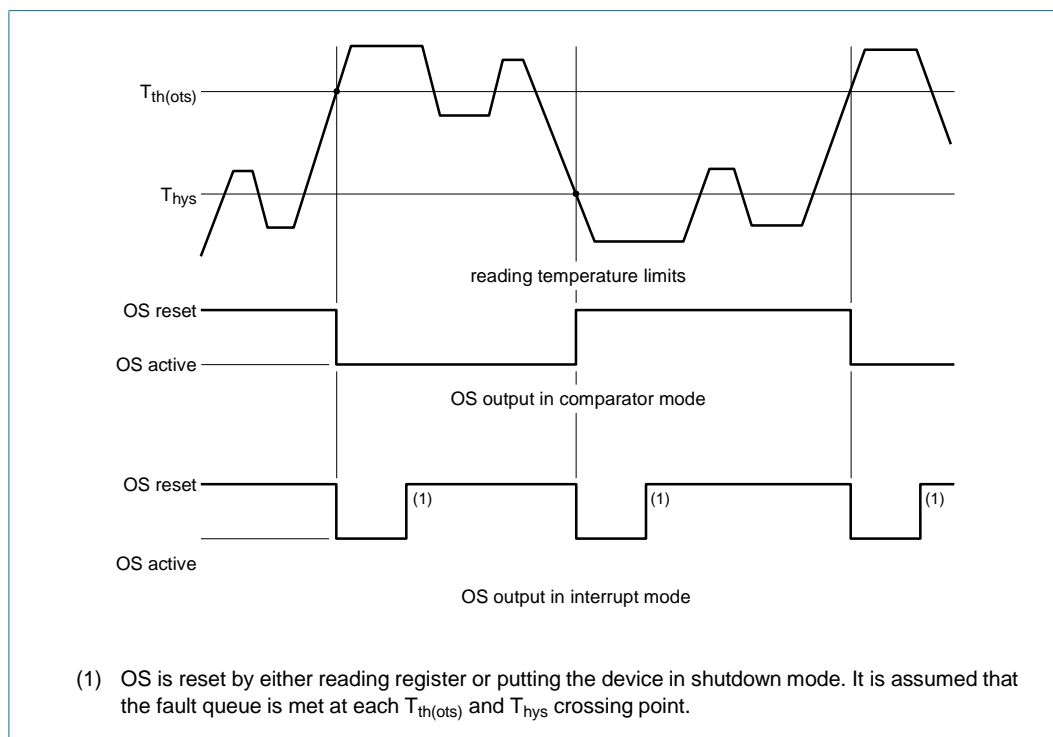

Fig 6. OS response to temperature

7.2 I²C-bus serial interface

The LM75BD,118 can be connected to a compatible 2-wire serial interface I²C-bus as a slave device under the control of a controller or master device, using two device terminals, SCL and SDA. The controller must provide the SCL clock signal and write/read data to/from the device through the SDA terminal. Notice that if the I²C-bus common pull-up resistors have not been installed as required for I²C-bus, then an external pull-up resistor, about 10 k Ω , is needed for each of these two terminals. The bus communication protocols are described in [Section 7.10](#).

7.2.1 Bus fault time-out

If the SDA line is held LOW for longer than t_{to} (75 ms minimum / 13.3 Hz; guaranteed at 50 ms minimum / 20 Hz), the LM75BD,118 will reset to the idle state (SDA released) and wait for a new START condition. This ensures that the LM75BD,118 will never hang up the bus should there be conflict in the transmission sequence.

7.3 Slave address

The LM75BD,118 slave address on the I²C-bus is partially defined by the logic applied to the device address pins A2, A1 and A0. Each of them is typically connected either to GND for logic 0, or to V_{CC} for logic 1. These pins represent the three LSB bits of the device 7-bit address. The other four MSB bits of the address data are preset to '1001' by hard wiring inside the LM75BD,118. [Table 4](#) shows the device's complete address and indicates that up to 8 devices can be connected to the same bus without address conflict. Because the input pins, SCL,SDA and A2to A0, are not internally biased, is important th at they should not be left floating in any application.

Table 4. Address table

1 = HIGH; 0 = LOW.

MSB				LSB		
1	0	0	1	A2	A1	A0

7.4 Register list

The LM75BD,118 contains four data registers beside the pointer register as listed in [Table 5](#). The pointer value, read/write capability and default content at power-up of the registers are also shown in [Table 5](#).

Table 5. Register table

Register name	Pointer value	R/W	POR state	Description
Conf	01h	R/W	00h	Configuration register: contains a single 8-bit data byte; to set the device operating condition; default = 0.
Temp	00h	read only	n/a	Temperature register: contains two 8-bit data bytes; to store the measured Temp data.
Tos	03h	R/W	5000h	Over temperature shutdown threshold register: contains two 8-bit data bytes; to store the over temperature shutdown $T_{th(ots)}$ limit; default = 80 °C.
Thyst	02h	R/W	4B00h	Hysteresis register: contains two 8-bit data bytes; to store the hysteresis T_{hys} limit; default = 75 °C.

7.4.1 Pointer register

The Pointer register contains an 8-bit data byte, of which the two LSB bits represent the pointer value of the other four registers, and the other 6 MSB bits are equal to 0, as shown in [Table 6](#) and [Table 7](#). The Pointer register is not accessible to the user, but is used to select the data register for write/read operation by including the pointer data byte in the bus command.

Table 6. Pointer register

B7	B6	B5	B4	B3	B2	B[1:0]
0	0	0	0	0	0	pointer value

Table 7. Pointer value

B1	B0	Selected register
0	0	Temperature register (Temp)
0	1	Configuration register (Conf)
1	0	Hysteresis register (Thyst)
1	1	Overtemperature shutdown register (Tos)

Because the Pointer value is latched into the Pointer register when the bus command (which includes the pointer byte) is executed, a read from the LM75BD,118 may or may not include the pointer byte in the statement. To read again a register that has been recently read and the pointer has been preset, the pointer byte does not have to be included. To read a register that is different from the one that has been recently read, the pointer byte must be included. However, a write to the LM75BD,118 must always include the pointer byte in the statement. The bus communication protocols are described in [Section 7.10](#).

At power-up, the Pointer value is equal to 00 and the Temp register is selected; users can then read the Temp data without specifying the pointer byte.

7.4.2 Configuration register

The Configuration register (Conf) is a write/read register and contains an 8-bit non-complement data byte that is used to configure the device for different operation conditions. [Table 8](#) shows the bit assignments of this register.

Table 8. Conf register

Legend: * = default value.

Bit	Symbol	Access	Value	Description
B[7:5]	reserved	R/W	000*	reserved for manufacturer's use; should be kept as zeroes for normal operation
B[4:3]	OS_F_QUE[1:0]	R/W		OS fault queue programming
			00*	queue value = 1
			01	queue value = 2
			10	queue value = 4
			11	queue value = 6
B2	OS_POL	R/W		OS polarity selection
			0*	OS active LOW
			1	OS active HIGH

Table 8. Conf register ...continued

Legend: * = default value.

Bit	Symbol	Access	Value	Description
B1	OS_COMP_INT	R/W		OS operation mode selection
			0*	OS comparator
			1	OS interrupt
B0	SHUTDOWN	R/W		device operation mode selection
			0*	normal
			1	shutdown

7.4.3 Temperature register

The Temperature register (Temp) holds the digital result of temperature measurement or monitor at the end of each analog-to-digital conversion. This register is read-only and contains two 8-bit data bytes consisting of one Most Significant Byte (MSByte) and one Least Significant Byte (LSByte). However, only 11 bits of those two bytes are used to store the Temp data in two's complement format with the resolution of 0.125 °C. [Table 9](#) shows the bit arrangement of the Temp data in the data bytes.

Table 9. Temp register

MSByte								LSByte							
7	6	5	4	3	2	1	0	7	6	5	4	3	2	1	0
D10	D9	D8	D7	D6	D5	D4	D3	D2	D1	D0	X	X	X	X	X

When reading register Temp, all 16 bits of the two data bytes (MSByte and LSByte) are provided to the bus and must be all collected by the controller to complete the bus operation. However, only the 11 most significant bits should be used, and the 5 least significant bits of the LSByte are zero and should be ignored. One of the ways to calculate the Temp value in °C from the 11-bit Temp data is:

1. If the Temp data MSByte bit D10 = 0, then the temperature is positive and Temp value (°C) = +(Temp data) × 0.125 °C.
2. If the Temp data MSByte bit D10 = 1, then the temperature is negative and Temp value (°C) = -(two's complement of Temp data) × 0.125 °C.

Examples of the Temp data and value are shown in [Table 10](#).

Table 10. Temp register value

11-bit binary (two's complement)	Hexadecimal value	Decimal value	Value
011 1111 1000	3F8	1016	+127.000 °C
011 1111 0111	3F7	1015	+126.875 °C
011 1111 0001	3F1	1009	+126.125 °C
011 1110 1000	3E8	1000	+125.000 °C
000 1100 1000	0C8	200	+25.000 °C
000 0000 0001	001	1	+0.125 °C
000 0000 0000	000	0	0.000 °C
111 1111 1111	7FF	-1	-0.125 °C

Table 10. Temp register value ...continued

11-bit binary (two's complement)	Hexadecimal value	Decimal value	Value
111 0011 1000	738	-200	-25.000 °C
110 0100 1001	649	-439	-54.875 °C
110 0100 1000	648	-440	-55.000 °C

For 9-bit Temp data application in replacing the industry standard XX75, just use only 9 MSB bits of the two bytes and disregard 7 LSB of the LSByte. The 9-bit Temp data with 0.5 °C resolution of the LM75BD,118 is defined exactly in the same way as for the standard XX75 and it is here similar to the Tos and Thyst registers.

The only MSByte of the temperature can also be read with the use of a one-byte reading command. Then the temperature resolution will be 1.00 °C instead.

7.4.4 Overtemperature shutdown threshold (Tos) and hysteresis (Thyst) registers

These two registers, are write/read registers, and also called set-point registers. They are used to store the user-defined temperature limits, called overtemperature shutdown threshold ($T_{th(ots)}$) and hysteresis temperature (T_{hys}), for the device watchdog operation. At the end of each conversion the Temp data will be compared with the data stored in these two registers in order to set the state of the device OS output; see [Section 7.1](#).

Each of the set-point registers contains two 8-bit data bytes consisting of one MSByte and one LSByte the same as register Temp. However, only 9 bits of the two bytes are used to store the set-point data in two's complement format with the resolution of 0.5 °C. [Table 11](#) and [Table 12](#) show the bit arrangement of the Tos data and Thyst data in the data bytes.

Notice that because only 9-bit data are used in the set-point registers, the device uses only the 9 MSB of the Temp data for data comparison.

Table 11. Tos register

MSByte									LSByte							
7	6	5	4	3	2	1	0		7	6	5	4	3	2	1	0
D8	D7	D6	D5	D4	D3	D2	D1		D0	X	X	X	X	X	X	X

Table 12. Thyst register

MSByte									LSByte							
7	6	5	4	3	2	1	0		7	6	5	4	3	2	1	0
D8	D7	D6	D5	D4	D3	D2	D1		D0	X	X	X	X	X	X	X

When a set-point register is read, all 16 bits are provided to the bus and must be collected by the controller to complete the bus operation. However, only the 9 most significant bits should be used and the 7 LSB of the LSByte are equal to zero and should be ignored.

[Table 13](#) shows examples of the limit data and value.

Table 13. Tos and Thyst limit data and value

11-bit binary (two's complement)	Hexadecimal value	Decimal value	Value
0 1111 1010	0FA	250	+125.0 °C
0 0011 0010	032	50	+25.0 °C
0 0000 0001	001	1	+0.5 °C
0 0000 0000	000	0	0.0 °C
1 1111 1111	1FF	-1	-0.5 °C
1 1100 1110	1CE	-50	-25.0 °C
1 1001 0010	192	-110	-55.0 °C

7.5 OS output and polarity

The OS output is an open-drain output and its state represents results of the device watchdog operation as described in [Section 7.1](#). In order to observe this output state, an external pull-up resistor is needed. The resistor should be as large as possible, up to 200 kΩ, to minimize the Temp reading error due to internal heating by the high OS sinking current.

The OS output active state can be selected as HIGH or LOW by programming bit B2 (OS_POL) of register Conf: setting bit OS_POL to logic 1 selects OS active HIGH and setting bit B2 to logic 0 sets OS active LOW. At power-up, bit OS_POL is equal to logic 0 and the OS active state is LOW.

7.6 OS comparator and interrupt modes

As described in [Section 7.1](#), the device OS output responds to the result of the comparison between register Temp data and the programmed limits, in registers Tos and Thyst, in different ways depending on the selected OS mode: OS comparator or OS interrupt. The OS mode is selected by programming bit B1 (OS_COMP_INT) of register Conf: setting bit OS_COMP_INT to logic 1 selects the OS interrupt mode, and setting to logic 0 selects the OS comparator mode. At power-up, bit OS_COMP_INT is equal to logic 0 and the OS comparator is selected.

The main difference between the two modes is that in OS comparator mode, the OS output becomes active when Temp has exceeded $T_{th(ots)}$ and reset when Temp has dropped below T_{hys} , reading a register or putting the device into shutdown mode does not change the state of the OS output; while in OS interrupt mode, once it has been activated either by exceeding $T_{th(ots)}$ or dropping below T_{hys} , the OS output will remain active indefinitely until reading a register, then the OS output is reset.

Temperature limits $T_{th(ots)}$ and T_{hys} must be selected so that $T_{th(ots)} > T_{hys}$. Otherwise, the OS output state will be undefined.

7.7 OS fault queue

Fault queue is defined as the number of faults that must occur consecutively to activate the OS output. It is provided to avoid false tripping due to noise. Because faults are determined at the end of data conversions, fault queue is also defined as the number of consecutive conversions returning a temperature trip. The value of fault queue is selectable by programming the two bits B4 and B3 (OS_F_QUE[1:0]) in register Conf. Notice that the programmed data and the fault queue value are not the same. [Table 14](#) shows the one-to-one relationship between them. At power-up, fault queue data = 0 and fault queue value = 1.

Table 14. Fault queue table

Fault queue data		Fault queue value
OS_F_QUE[1]	OS_F_QUE[0]	Decimal
0	0	1
0	1	2
1	0	4
1	1	6

7.8 Shutdown mode

The device operation mode is selected by programming bit B0 (SHUTDOWN) of register Conf. Setting bit SHUTDOWN to logic 1 will put the device into shutdown mode. Resetting bit SHUTDOWN to logic 0 will return the device to normal mode.

In shutdown mode, the device draws a small current of approximately 1.0 μA and the power dissipation is minimized; the temperature conversion stops, but the I²C-bus interface remains active and register write/read operation can be performed. When the shutdown is set, the OS output will be unchanged in comparator mode and reset in interrupt mode.

7.9 Power-up default and power-on reset

The LM75BD,118 always powers-up in its default state with:

- Normal operation mode
- OS comparator mode
- $T_{th(ots)} = 80\text{ }^{\circ}\text{C}$
- $T_{hys} = 75\text{ }^{\circ}\text{C}$
- OS output active state is LOW
- Pointer value is logic 00 (Temp)

When the power supply voltage is dropped below the device power-on reset level of approximately 1.0 V (POR) for over 2 μs and then rises up again, the device will be reset to its default condition as listed above.

7.10 Protocols for writing and reading the registers

The communication between the host and the LM75BD,118 must strictly follow the rules as defined by the I²C-bus management. The protocols for LM75BD,118 register read/write operations are illustrated in [Figure 7](#) to [Figure 12](#) together with the following definitions:

1. Before a communication, the I²C-bus must be free or not busy. It means that the SCL and SDA lines must both be released by all devices on the bus, and they become HIGH by the bus pull-up resistors.
2. The host must provide SCL clock pulses necessary for the communication. Data is transferred in a sequence of 9 SCL clock pulses for every 8-bit data byte followed by 1-bit status of the acknowledgement.
3. During data transfer, except the START and STOP signals, the SDA signal must be stable while the SCL signal is HIGH. It means that the SDA signal can be changed only during the LOW duration of the SCL line.
4. S: START signal, initiated by the host to start a communication, the SDA goes from HIGH to LOW while the SCL is HIGH.
5. RS: RE-START signal, same as the START signal, to start a read command that follows a write command.
6. P: STOP signal, generated by the host to stop a communication, the SDA goes from LOW to HIGH while the SCL is HIGH. The bus becomes free thereafter.
7. W: write bit, when the write/read bit = LOW in a write command.
8. R: read bit, when the write/read bit = HIGH in a read command.
9. A: device acknowledge bit, returned by the LM75BD,118. It is LOW if the device works properly and HIGH if not. The host must release the SDA line during this period in order to give the device the control on the SDA line.
10. A': master acknowledge bit, not returned by the device, but set by the master or host in reading 2-byte data. During this clock period, the host must set the SDA line to LOW in order to notify the device that the first byte has been read for the device to provide the second byte onto the bus.
11. NA: Not Acknowledge bit. During this clock period, both the device and host release the SDA line at the end of a data transfer, the host is then enabled to generate the STOP signal.
12. In a write protocol, data is sent from the host to the device and the host controls the SDA line, except during the clock period when the device sends the device acknowledgement signal to the bus.
13. In a read protocol, data is sent to the bus by the device and the host must release the SDA line during the time that the device is providing data onto the bus and controlling the SDA line, except during the clock period when the master sends the master acknowledgement signal to the bus.

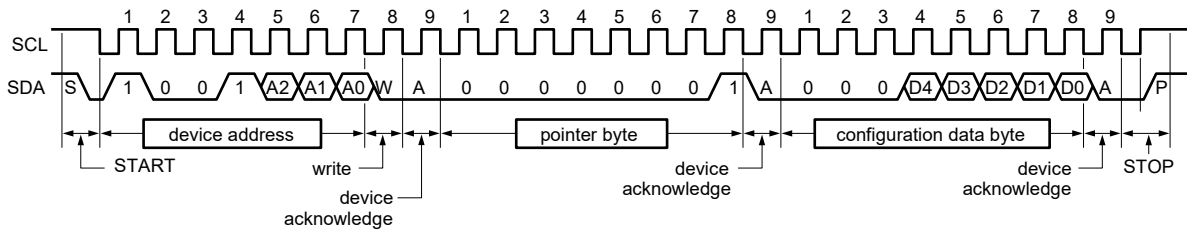

Fig 7. Write configuration register (1-byte data)

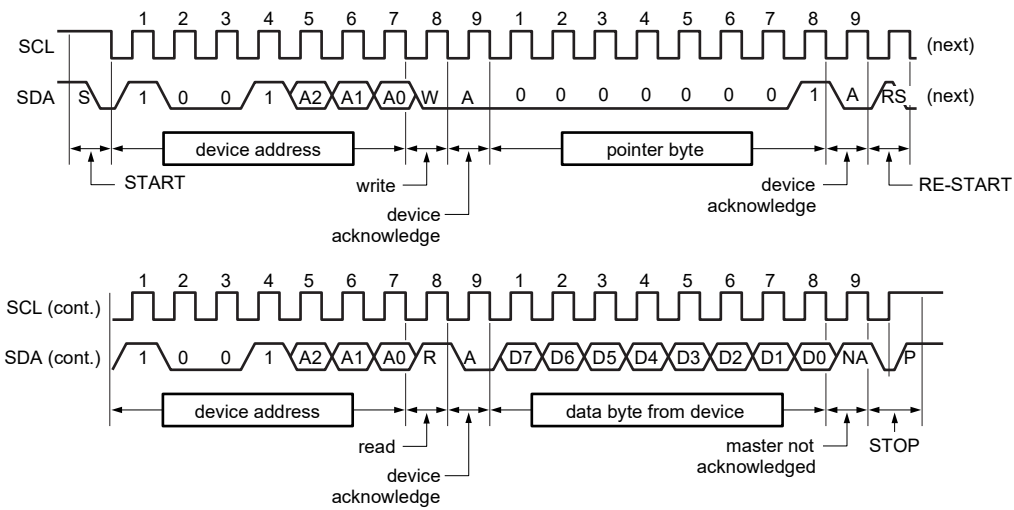

Fig 8. Read configuration register including pointer byte (1-byte data)

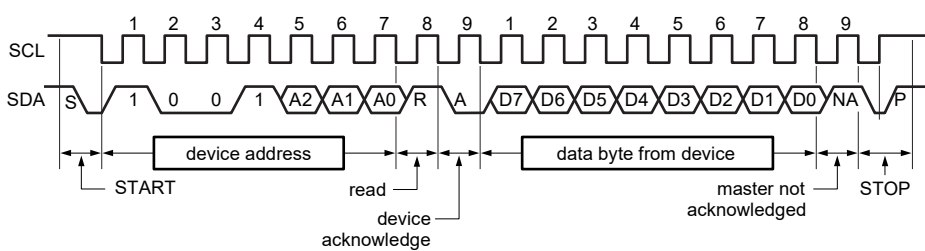

Fig 9. Read configuration or temp register with preset pointer (1-byte data)

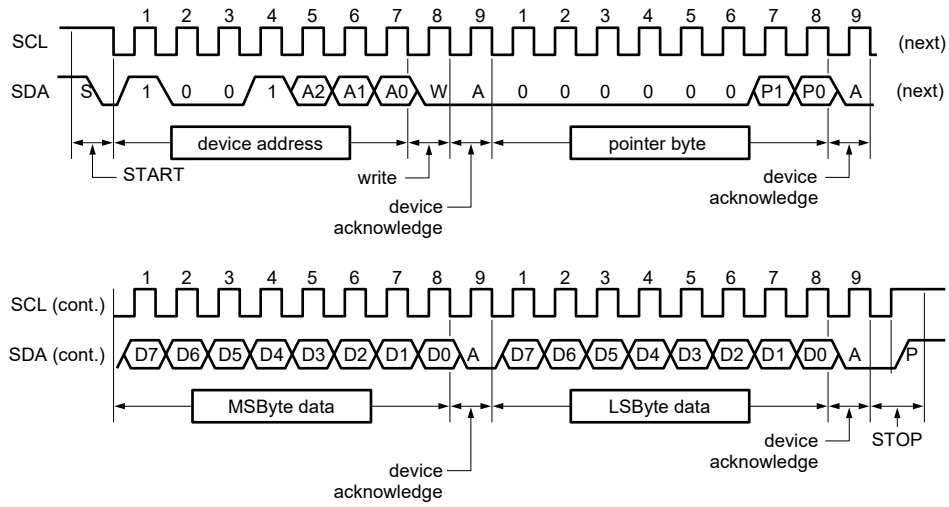

Fig 10. Write Tos or Thyst register (2-byte data)

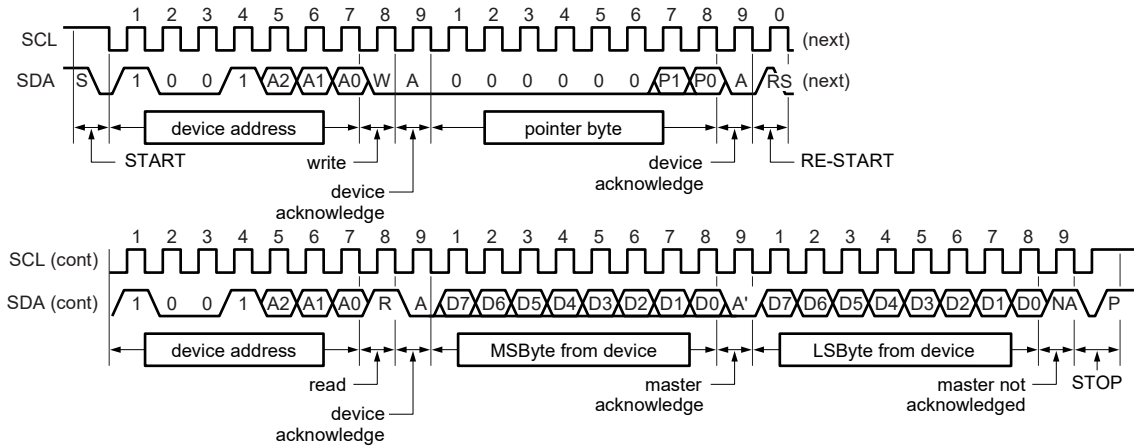

Fig 11. Read Temp, Tos or Thyst register including pointer byte (2-byte data)

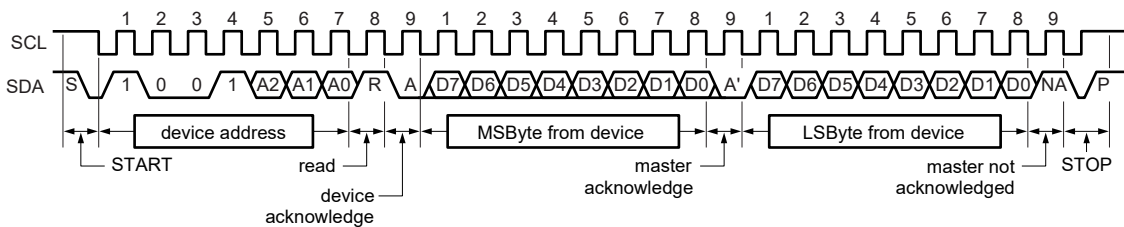

Fig 12. Read Temp, Tos or Thyst register with preset pointer (2-byte data)

8. Application design-in information

8.1 Typical application

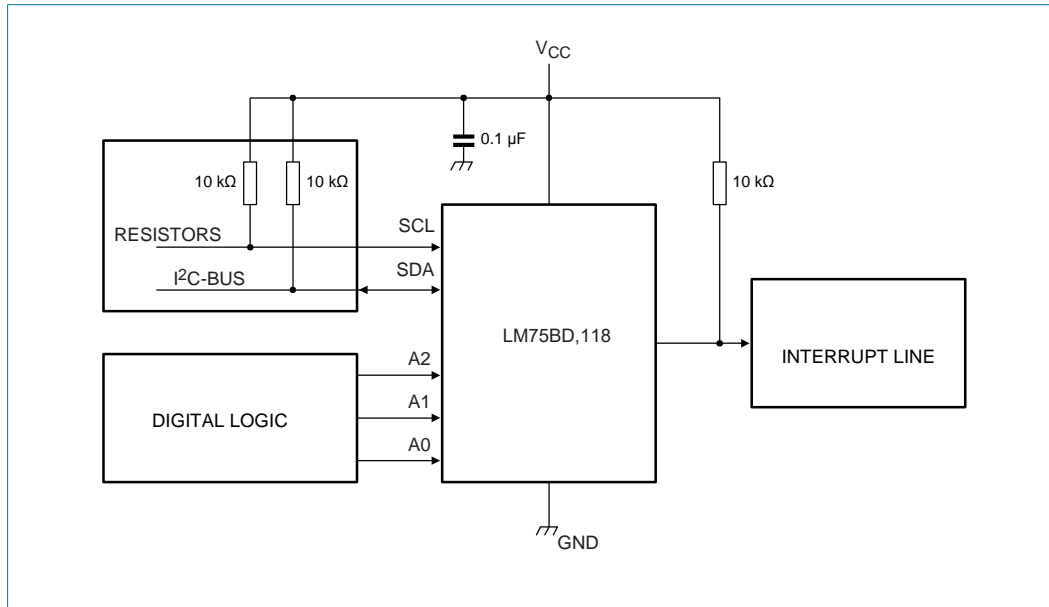

Fig 13. Typical application

8.2 Temperature accuracy

Because the local channel of the temperature sensor measures its own die temperature that is transferred from its body, the temperature of the device body must be stabilized and saturated for it to provide the stable readings. Because the LM75BD,118 operates at a low power level, the thermal gradient of the device package has a minor effect on the measurement. The accuracy of the measurement is more dependent upon the definition of the environment temperature, which is affected by different factors: the printed-circuit board on which the device is mounted; the air flow contacting the device body (if the ambient air temperature and the printed-circuit board temperature are much different, then the measurement may not be stable because of the different thermal paths between the die and the environment). The stabilized temperature liquid of a thermal bath will provide the best temperature environment when the device is completely dipped into it. A thermal probe with the device mounted inside a sealed-end metal tube located in consistent temperature air also provides a good method of temperature measurement.

If you would like to calculate the effect of self-heating, use [Equation 1](#) below:

[Equation 1](#) is the formula to calculate the effect of self-heating:

$$\Delta T = R_{th(j-a)} \times [(V_{DD} \times I_{DD(AV)}) + (V_{OL(SDA)} \times I_{OL(sink)(SDA)}) + (V_{OL(EVENT)} \times I_{OL(sink)EVENT})] \quad (1)$$

where:

$$\Delta T = T_j - T_{amb}$$

T_j = junction temperature

T_{amb} = ambient temperature

$R_{th(j-a)}$ = package thermal resistance

V_{DD} = supply voltage

$I_{DD(AV)}$ = average supply current

$V_{OL(SDA)}$ = LOW-level output voltage on pin SDA

$V_{OL(EVENT)}$ = LOW-level output voltage on pin \overline{EVENT}

$I_{OL(sink)(SDA)}$ = SDA output current LOW

$I_{OL(sink)EVENT}$ = \overline{EVENT} output current LOW

Calculation example:

T_{amb} (typical temperature inside the notebook) = 50 °C

$I_{DD(AV)}$ = 400 μ A

V_{DD} = 3.6 V

Maximum $V_{OL(SDA)}$ = 0.4 V

$I_{OL(sink)(SDA)}$ = 1 mA

$V_{OL(EVENT)}$ = 0.4 V

$I_{OL(sink)EVENT}$ = 3 mA

$R_{th(j-a)}$ = 56 °C/W

Self heating due to power dissipation is:

$$\Delta T = 56 \times [(3.6 \times 0.4) + (0.4 \times 3) + (0.4 \times 1)] = 56 \text{ °C/W} \times 3.04 \text{ mW} = 0.17 \text{ °C} \quad (2)$$

8.3 Noise effect

The LM75BD,118 device design includes the implementation of basic features for a good noise immunity:

- The low-pass filter on both the bus pins SCL and SDA;
- The hysteresis of the threshold voltages to the bus input signals SCL and SDA, about 500 mV minimum;
- All pins have ESD protection circuitry to prevent damage during electrical surges. The ESD protection on the address, OS, SCL and SDA pins is to ground. The latch-back based device breakdown voltage of address/OS is typically 11 V and SCL/SDA is typically 9.5 V at any supply voltage but will vary over process and temperature. Since there are no protection diodes from SCL or SDA to V_{CC} , the LM75BD,118 will not hold the I2C lines LOW when V_{CC} is not supplied and therefore allow continued I2C-bus operation if the LM75BD,118 is de-powered.

However, good layout practices and extra noise filters are recommended when the device is used in a very noisy environment:

- Use decoupling capacitors at V_{CC} pin.
- Keep the digital traces away from switching power supplies.
- Apply proper terminations for the long board traces.
- Add capacitors to the SCL and SDA lines to increase the low-pass filter characteristics.

9. Limiting values

Table 16. Limiting values

In accordance with the Absolute Maximum Rating System (IEC 60134).

Symbol	Parameter	Conditions	Min	Max	Unit
V_{CC}	supply voltage		-0.3	+6.0	V
V_I	input voltage	at input pins	-0.3	+6.0	V
I_I	input current	at input pins	-5.0	+5.0	mA
$I_{O(sink)}$	output sink current	on pin OS	-	10.0	mA
V_O	output voltage	on pin OS	-0.3	+6.0	V
T_{stg}	storage temperature		-65	+150	°C
T_j	junction temperature		-	150	°C

10. Recommended operating conditions

Table 17. Recommended operating characteristics

Symbol	Parameter	Conditions	Min	Typ	Max	Unit
V_{CC}	supply voltage		2.8	-	5.5	V
T_{amb}	ambient temperature		-55	-	+125	°C

11. Static characteristics

Table 18. Static characteristics
 $V_{CC} = 2.8\text{ V to }5.5\text{ V}$; $T_{amb} = -55^{\circ}\text{ C to }+125^{\circ}\text{ C}$; unless otherwise specified.

Symbol	Parameter	Conditions	Min	Typ ^[1]	Max	Unit
T_{acc}	temperature accuracy	$T_{amb} = -25^{\circ}\text{ C to }+100^{\circ}\text{ C}$	-1	-	+1	$^{\circ}\text{C}$
		$T_{amb} = -55^{\circ}\text{ C to }+125^{\circ}\text{ C}$	-2	-	+2	$^{\circ}\text{C}$
T_{res}	temperature resolution	11-bit digital temp data	-	0.125	-	$^{\circ}\text{C}$
$t_{conv(T)}$	temperature conversion time	normal mode	-	10	-	ms
T_{conv}	conversion period	normal mode	-	100	-	ms
$I_{DD(AV)}$	average supply current	normal mode: I ² C-bus inactive	-	80	200	μA
		normal mode: I ² C-bus active; $f_{SCL} = 400\text{ kHz}$	-	-	300	μA
		shutdown mode	-	0.3	5.0	μA
V_{IH}	HIGH-level input voltage	digital pins (SCL, SDA, A2 to A0)	$0.7 \times V_{CC}$	-	$V_{CC} + 0.3$	V
V_{IL}	LOW-level input voltage	digital pins	-0.3	-	$0.3 \times V_{CC}$	V
$V_{I(hys)}$	hysteresis of input voltage	SCL and SDA pins	-	300	-	mV
		A2, A1, A0 pins	-	150	-	mV
I_{IH}	HIGH-level input current	digital pins; $V_I = V_{CC}$	-1.0	-	+1.0	μA
I_{IL}	LOW-level input current	digital pins; $V_I = 0\text{ V}$	-1.0	-	+1.0	μA
V_{OL}	LOW-level output voltage	SDA and OS pins; $I_{OL} = 3\text{ mA}$	-	-	0.4	V
		$I_{OL} = 4\text{ mA}$	-	-	0.8	V
I_{LO}	output leakage current	SDA and OS pins; $V_{OH} = V_{CC}$	-	-	10	μA
N_{fault}	number of faults	programmable; conversions in overtemperature-shutdown fault queue	1	-	6	
$T_{th(ots)}$	overtemperature shutdown threshold temperature	default value	-	80	-	$^{\circ}\text{C}$
T_{hys}	hysteresis temperature	default value	-	75	-	$^{\circ}\text{C}$
C_i	input capacitance	digital pins	-	20	-	pF

[1] Typical values are at $V_{CC} = 3.3\text{ V}$ and $T_{amb} = 25^{\circ}\text{ C}$.

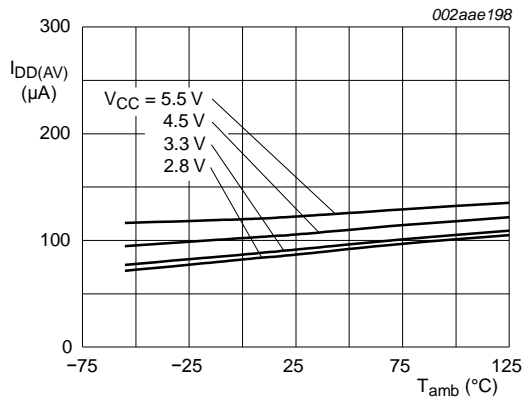

Fig 14. Average supply current versus temperature; I²C-bus inactive

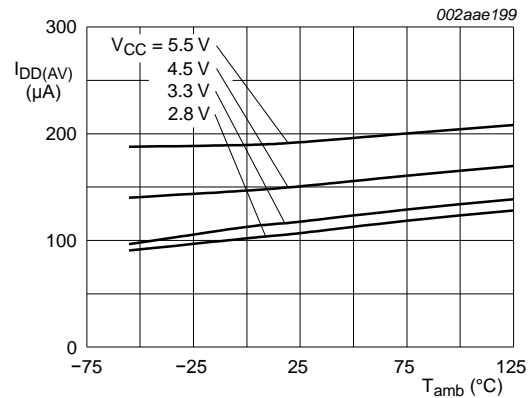

Fig 15. Average supply current versus temperature; I²C-bus active

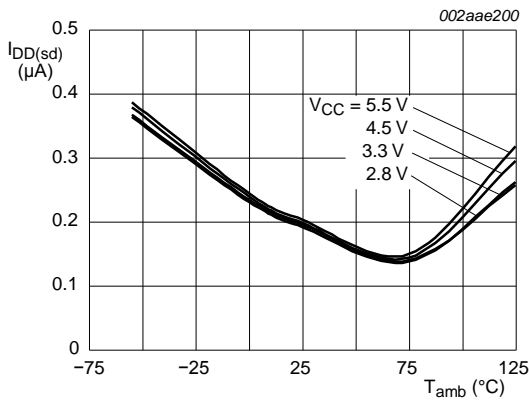

Fig 16. Shutdown mode supply current versus temperature

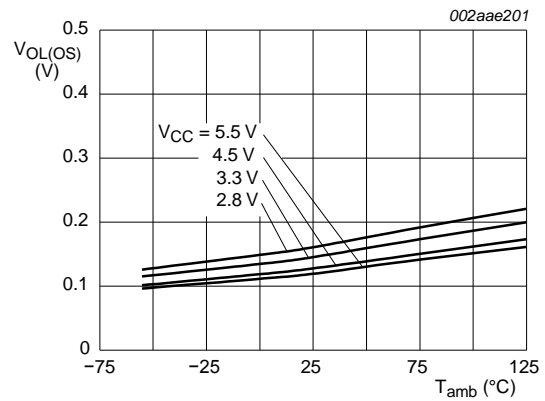

Fig 17. LOW-level output voltage on pin OS versus temperature; $I_{OL} = 4 mA$

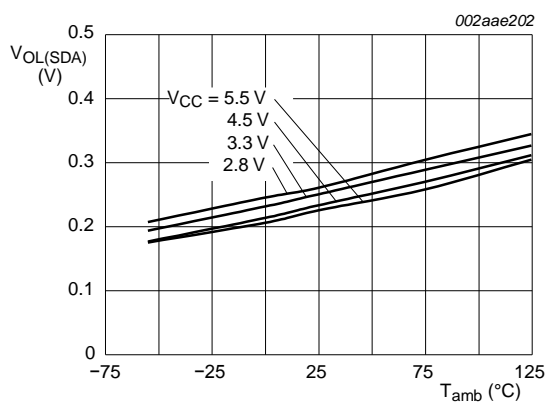

Fig 18. LOW-level output voltage on pin SDA versus temperature; $I_{OL} = 4 mA$

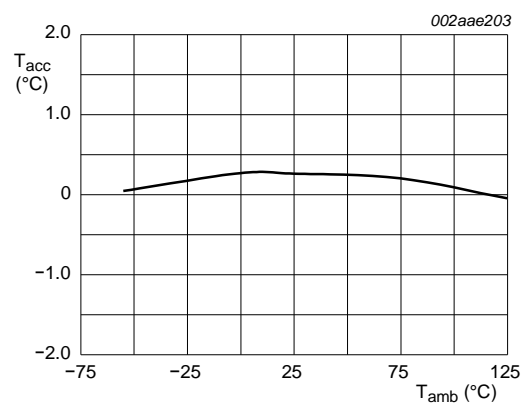

Fig 19. Typical temperature accuracy versus temperature; $V_{CC} = 3.3 V$

12. Dynamic characteristics

Table 19. I²C-bus interface dynamic characteristics^[1]
 $V_{CC} = 2.8\text{ V to }5.5\text{ V}; T_{amb} = -55^{\circ}\text{ C to }+125^{\circ}\text{ C};$ unless otherwise specified.

Symbol	Parameter	Conditions	Min	Typ	Max	Unit
f_{SCL}	SCL clock frequency	see Figure 20	0.02	-	400	kHz
t_{HIGH}	HIGH period of the SCL clock		0.6	-	-	μs
t_{LOW}	LOW period of the SCL clock		1.3	-	-	μs
$t_{SU;STA}$	set-up time START condition		0.6	-	-	μs
$t_{HD;STA}$	hold time (repeated) START condition		100	-	-	ns
$t_{SU;STO}$	set-up time STOP condition		100	-	-	ns
t_{BUF}	Idle time between the start signal and the stop signal		1.3	-	-	μs
$t_{SU;DAT}$	data set-up time		100	-	-	ns
$t_{HD;DAT}$	data hold time		0	-	-	ns
t_R	rise time		-	-	300	ns
t_f	fall time	SDA and OS outputs; $C_L = 400\text{ pF}; I_{OL} = 3\text{ mA}$	-	250	-	ns
t_{to}	time-out time		^{[2][3]} 18	20	26	ms

[1] These specifications are guaranteed by design and not tested in production.

[2] This is the SDA time LOW for reset of serial interface.

[3] Holding the SDA line LOW for a time greater than t_{to} will cause the LM75BD,118 to reset SDA to the idle state of the serial bus communication (SDA set HIGH).

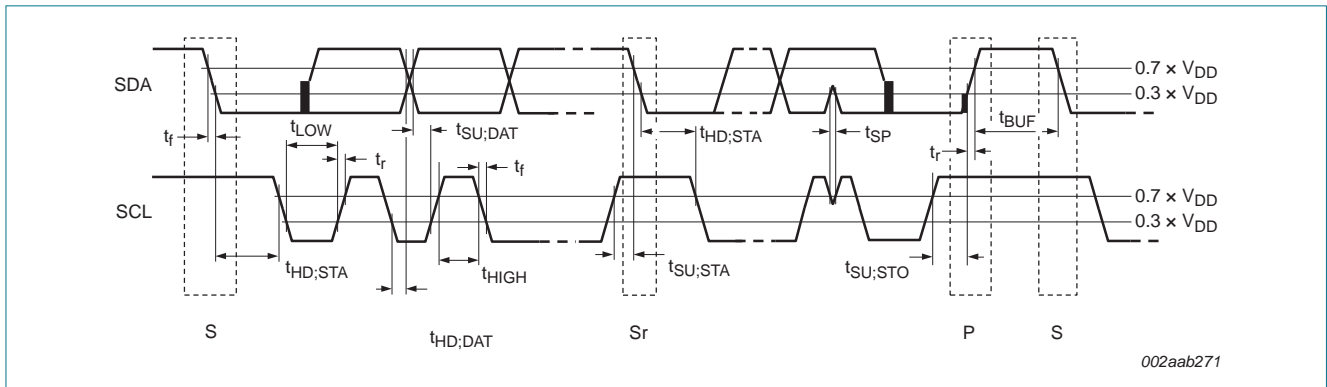
Fig 20. Timing diagram

13. Package outline

SOP8: plastic small outline package; 8 leads; body width 3.9 mm

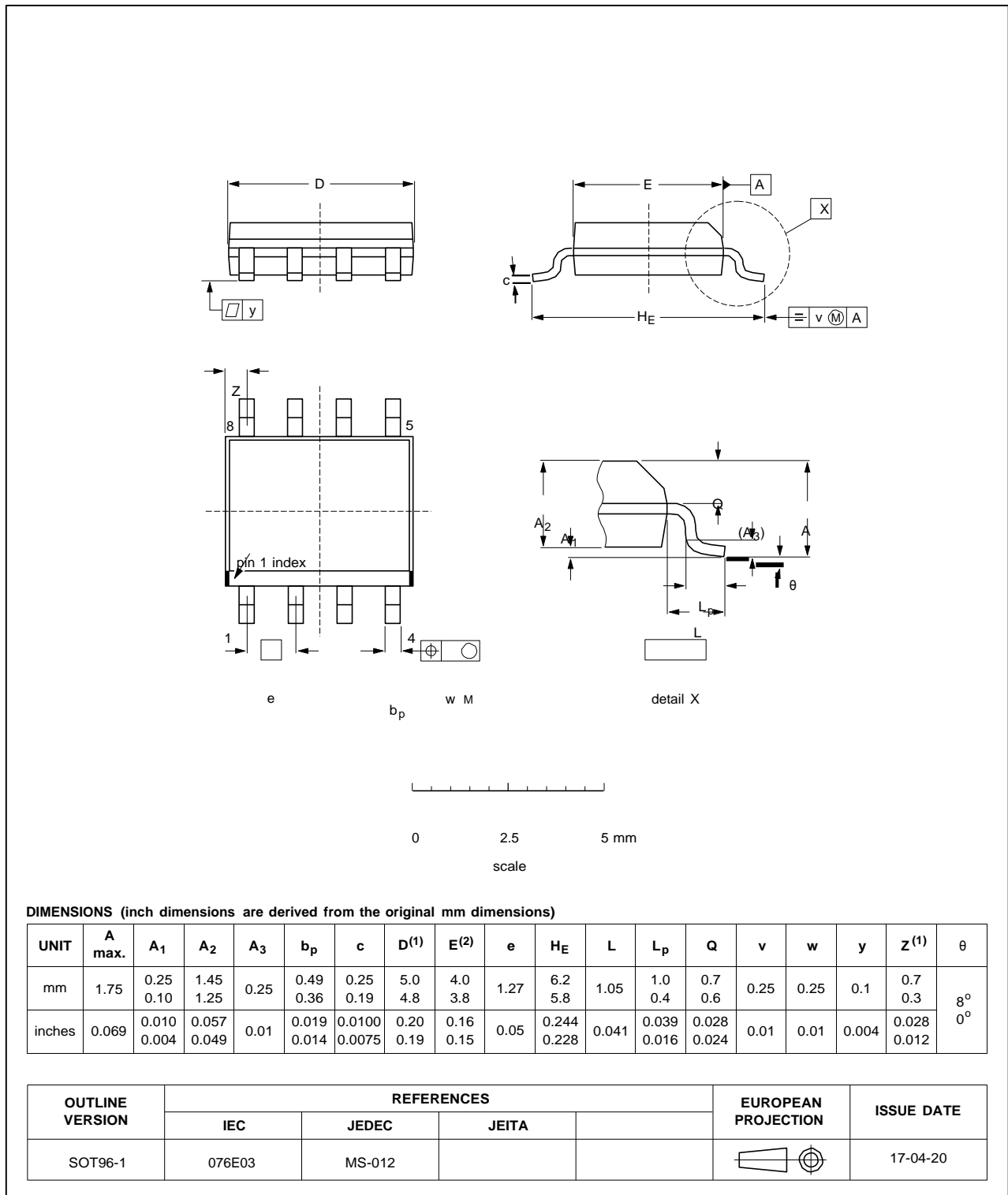

Notes

1. Plastic or metal protrusions of 0.15 mm (0.006 inch) maximum per side are not included.
2. Plastic or metal protrusions of 0.25 mm (0.01 inch) maximum per side are not included.

Fig 21. Package outline SOP8

14. Soldering: PCB footprints

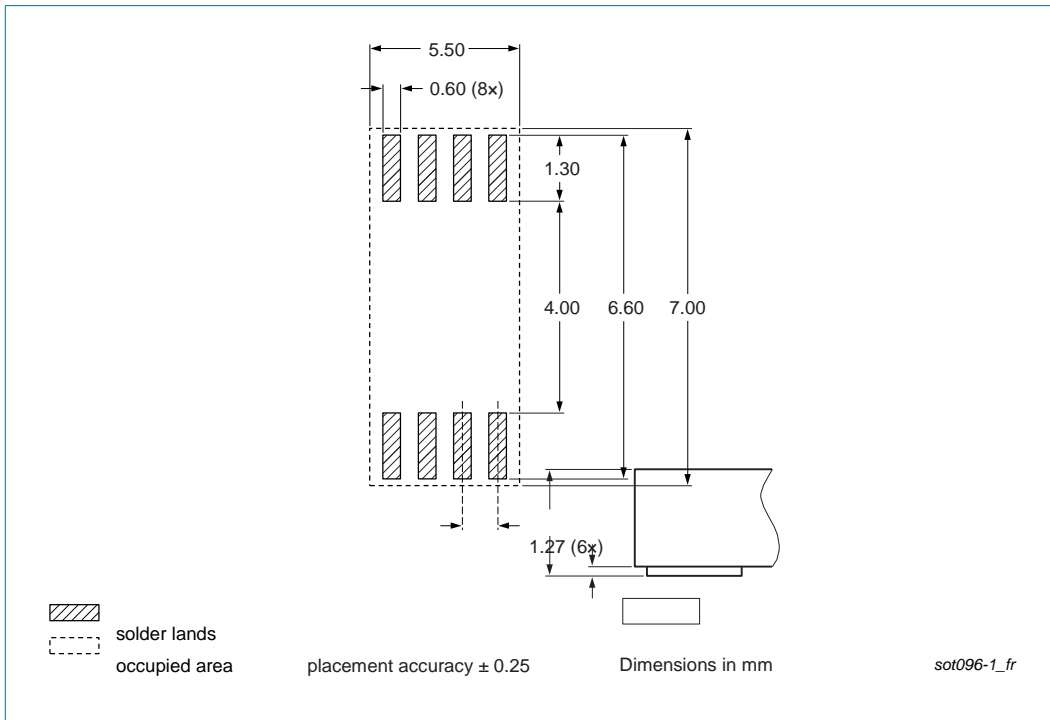

Fig 22. PCB footprint for SOP8