

REV. (版本号)	DESCRIPTION (变更说明)	DATE (日期)	APPD (核准)
A0	新订图面	2021.03.11	Lee

- NOTES:
SPECIFICATION:
- CURRENT RATING: 3.0A MAX
 - VOLTAGE: 100 VAC
 - TEMPERATURE RANGE: -30°C~+85°C
 - CONTACT RESISTANCE: 40 MILLIONHM MAX
 - INSULATION RESISTANCE: 100 MEGOHMS MIN
 - INSERTION FORCE: 5N~20N
 - UNMATING FORCE: 8N~20N
 - DURABILITY: 10000 CYCLES

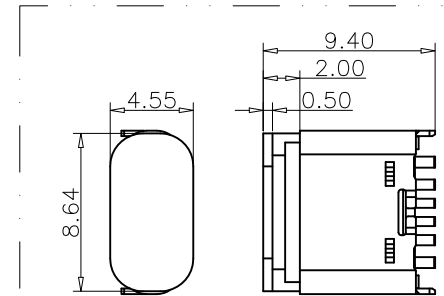

加塞子示意图
SCALE 2:1

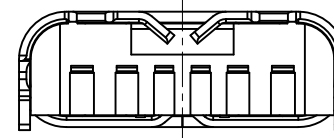
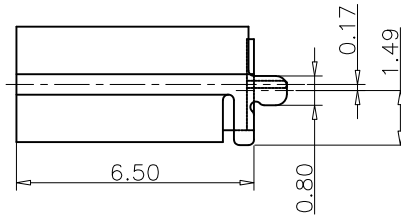
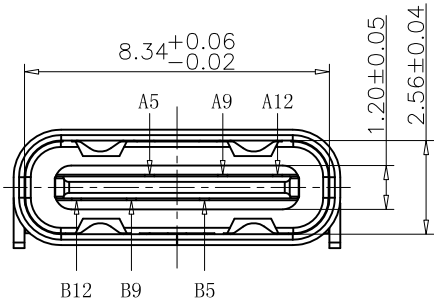
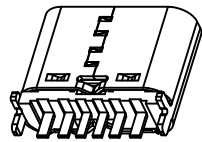
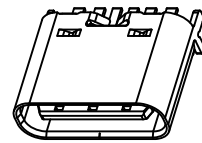
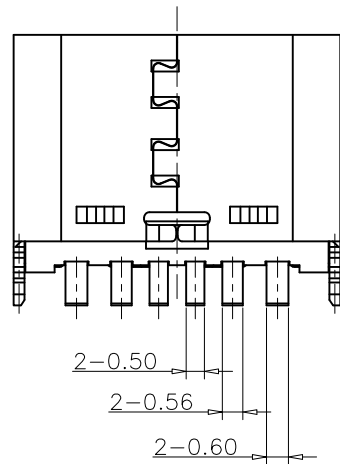

端子 3B
中隔片 1A
外壳 5B

USB TYPE C PIN ASSIGNMENTS

PIN NUMBER	SIGNAL NAME	PIN NUMBER	SIGNAL NAME
A5	CC1	B12	GND
A9	VBUS	B9	VBUS
A12	GND	B5	CC2

TABLE:

NO	PART	Q'TY	Material
1	SHELL	1	STAINLESS STEEL,NI PLATED
2	CONTACT	6	COPPER STEEL,TIN/Au/NI PLATED
3	HOUSING	1	HIGH TEMPERATURE RESISTANT PLASTIC BLACK UL94 V-0

YWF 深圳市宇文发电子科技有限公司
Shen Zhen Yu Wen Fa Electronics Technology Co.,Ltd
TEL:0755-27711235 FAX:0755-27712683

品名 (ITEM NO)	TYPE CF 6P单排直立式DIP H=6.5(TO.3/脚长0.9)
料号 (PART NO)	PTCFW-R13D-003
图号 (DWG NO)	P-TCF-042

页码 (SHEET)	1/1	单位 (UNIT):	MM
版本 (REV)	A0	比例 (SCALE):	1:1
日期 (DATE)	2021.03.11		
设计 (DESIGN)	Lee		
审核 (CHECKED)			
核准 (APPROVED)			

未注公差
TOLERANCE UNSPECIFIED

X.X	±0.30
X.XX	±0.20
X.XXX	±0.10
X°	±5°
X.X°	±2°

RoHS Compliant

REV.	ECN NO	DESCRIPTION	REVISER	DATE
A/0				
A/1				

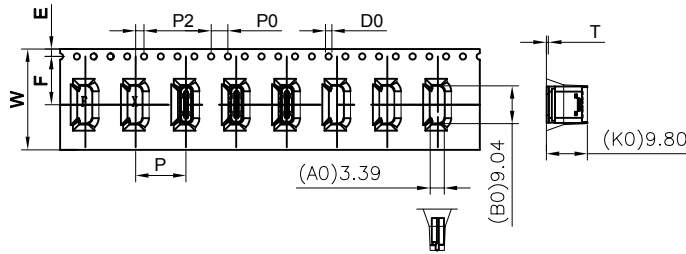
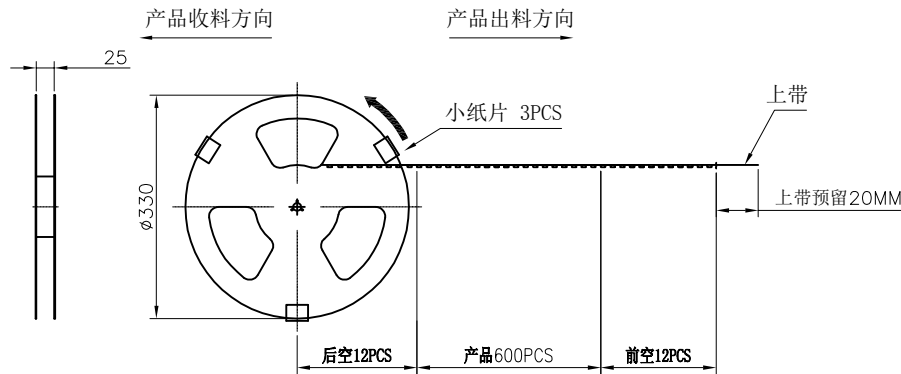

*内盘标签样式

Item No. :	USB4125-GF-A	←料 號
Batch No:	200921-001	←樣式為“YYMMDD-001”，請按生產批次的年月日來填寫
Quantity :	600 PCS	←每卷轉載貨數量

备注:

1. 每盘装600PCS,并贴上3PCS美纹胶,然后贴上对应的产品标签。
2. 每盘真空包装(注意: 不能将载带或盘子压变形)
3. 外箱底部先垫一隔板,并在外箱四个内角各放置一个三角架,把10卷(6000PCS)封装好的产品标签一律朝上平放进外箱中上层盖上一隔板,再用封箱胶纸将外箱口於“工”字型封好。

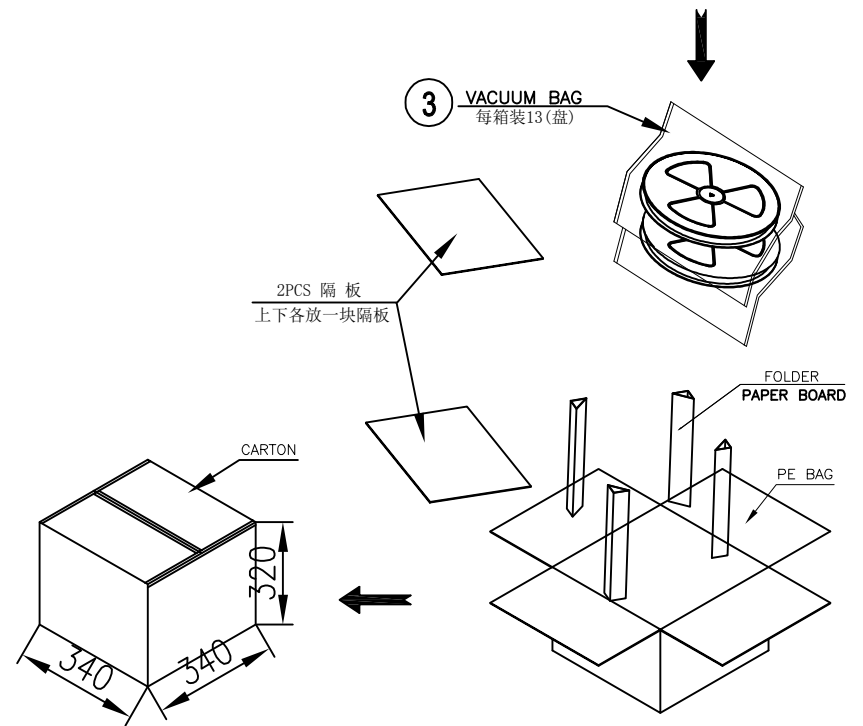
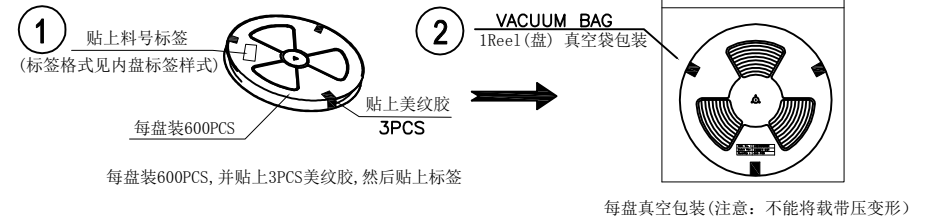

PART NO.	REEL/TRAY	CARTON	净重 (KG)	毛重 (KG)	外箱尺寸
USB4125-GF-A	600	6000			L=340mm*W=340mm*H=320mm

图号 (DWG NO)		单位 (UNIT):	MM	深圳宇文发电子科技有限公司 TEL:0755-27711235 FAX:0755-27712683	
日期 (DATE)	2021.01.22	比例 (SCALE):	1:1		
版次 (REV):	A/0	页/次 (PAGE):	1/1		
设计 (DESIGN)	Lee	包装规范		品名 (ITEM NO)	USB C F 6PIN单排直立式SMTH6.5-真空包装规范
审核 (CHECKED)				料号 (PART NO)	A-004R-085
核准 (APPROVED)					