

## 4V-60V 1A Non-Synchronous Step-Down DCDC Converter With High Efficiency Sleep Mode

### FEATURES

- Wide Input Range: 4V-60V
- Up to maximum 1A Continuous Output Current
- $0.770V \pm 2.5\%$  Feedback Reference Voltage
- Integrated  $542m\Omega$  High-Side Power MOSFET
- Fixed Frequency 600kHz
- Pulse Skipping Mode (PSM) at Light Load
- 80ns Minimum On-time
- 5ms Internal Soft-start Time
- UVLO, OTP and Cycle-by-Cycle Current Protection
- Available in TSOT23-6L

### APPLICATIONS

- Industrial Distributed Power Bus
- Battery Powered Equipment
- Elevator, PLC, Servo
- Automatic Control
- Automotive

### ORDERING INFORMATION

TYPE	MARKING	PACKAGE
LMR16006XDDCR	1600A	TSOT23-6L

### TYPICAL APPLICATIONS

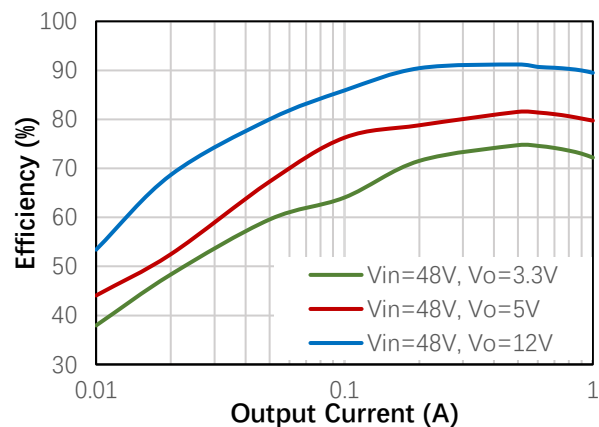
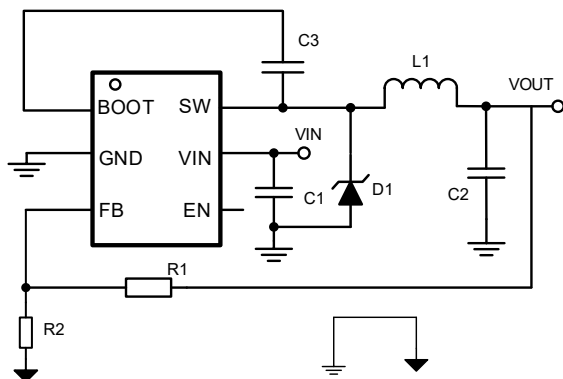

## PIN CONFIGURATION AND FUNCTIONS

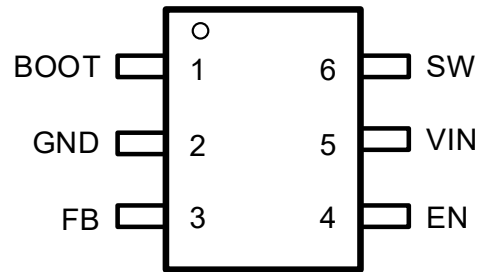

Top View: LMR16006XDDCR TSOT23-6L

PIN OUT		I/O	PIN FUNCTION
NAME	SOT23-6 NO.		
BOOT	1	I	Power supply for the high-side power MOSFET gate driver. Must connect a 0.1uF or greater ceramic capacitor between BST pin and SW node.
GND	2	G	Power ground.
FB	3	I	Buck converter output feedback sensing voltage. Connect a resistor divider from VOUT to FB to set up output voltage. The device regulates FB to the internal reference of 0.770V typically.
EN	4	I	Enable logic input. Floating the pin enables the device. This pin supports high voltage input up to VIN supply to be connected VIN directly to enable the device automatically. The device has precision enable thresholds 1.21V rising / 1.07V falling for programmable UVLO threshold and hysteresis.
VIN	5	I	Power supply input. Must be locally bypassed.
SW	6	O	Switching node of the buck converter.
NC		-	No connection internally.

## SPECIFICATIONS

### ABSOLUTE MAXIMUM RATINGS

Over operating free-air temperature unless otherwise noted

DESCRIPTION	PARAMETER	MIN	MAX	UNIT
Input Voltage	V <sub>IN</sub> , EN to GND	-0.3	65	V
	FB to GND	-0.3	6.5	V
Output Voltage	SW to GND	-0.6	65	V
	SW to GND ( ≤20ns transients)	-4	65	V
	BOOT to SW	-0.3	6.5	V
Junction temperature	T <sub>J</sub>	-40	150	°C
Storage temperature	T <sub>STG</sub>	-65	150	°C

### ESD RATINGS

PARAMETER	DEFINITION	MIN	MAX	UNIT
V <sub>ESD</sub>	Human Body Model (HBM), per ANSI-JEDEC-JS-001-2014 specification, all pins <sup>(1)</sup>	-2000	+2000	V
	Charged Device Model (CDM), per ANSI-JEDEC-JS-002-2014 specification, all pins <sup>(1)</sup>	-500	+500	V

(1) HBM and CDM stressing are done in accordance with the ANSI/ESDA/JEDEC JS-001-2014 specification

### RECOMMENDED OPERATING CONDITIONS

Over operating free-air temperature range unless otherwise noted

PARAMETER	DEFINITION	MIN	MAX	UNIT
V <sub>IN</sub>	Supply voltage range	4	60	V
I <sub>o</sub>	Output Current	0	1	A
V <sub>o</sub>	Output Voltage		V <sub>VIN</sub> -4.5	V
V <sub>EN</sub>	EN pin voltage	0	60	V
f <sub>SW</sub>	Switching frequency range	510	690	kHz
T <sub>J</sub>	Operating junction temperature	-40	125	°C

## THERMAL INFORMATION

PARAMETER	THERMAL METRIC	TSOT23-6L	UNIT
R <sub>θJA</sub>	Junction to ambient thermal resistance	102	°C/W
R <sub>θJC_top</sub>	Junction to case (top) thermal resistance	37	°C/W

## ELECTRICAL CHARACTERISTICS

V<sub>VIN</sub>=V<sub>EN</sub>=12V, T<sub>J</sub>=-40°C~125°C, typical values are tested under 25°C.

SYMBOL	PARAMETER	TEST CONDITION	MIN	TYP	MAX	UNIT
<b>Power Supply</b>						
V <sub>VIN</sub>	Operating input voltage		4		60	V
V <sub>VIN_UVLO</sub>	Input UVLO	VIN rising		3.75	3.9	V
	Hysteresis			220		mV
I <sub>SHDN</sub>	Shutdown current	EN=0, No load, 4V≤V <sub>VIN</sub> ≤60V		1	8	uA
I <sub>Q</sub>	Quiescent current	EN=floating, No load, No switch, 4V≤V <sub>VIN</sub> ≤60V, BOOT-SW=5V		80	109	uA
<b>Enable and Feedback</b>						
V <sub>EN_H</sub>	Enable high threshold		1.18	1.21	1.24	V
V <sub>EN_L</sub>	Enable low threshold			1.07		V
V <sub>FB</sub>	Feedback Voltage		750	770	790	mV
<b>Power MOSFET</b>						
R <sub>DSON_H</sub>	High side FET on-resistance		360	542	950	mΩ
<b>Switching Characteristics</b>						
f <sub>SW</sub>	Switching frequency		510	600	690	KHz
t <sub>ON_MIN</sub>	Minimum on-time			80		ns
<b>Soft Start Time and Protection</b>						
t <sub>SS</sub>	Internal soft-start time			5		ms
I <sub>LIM_HSD</sub>	HSD peak current limit	V <sub>VIN</sub> =12V		1.5		A
T <sub>SD</sub>	Thermal shutdown threshold			160		°C
	Hysteresis			30		

---

SYMBOL	PARAMETER	TEST CONDITION	MIN	TYP	MAX	UNIT
<b>Output Voltage Protection</b>						
V <sub>OVP_H</sub>	Output over voltage protection rising			109		%
V <sub>OVP_L</sub>	Output over voltage protection falling			105		%

## TYPICAL CHARACTERISTICS

VIN=24V, L=33uH, Cout=22uF, TA= 25°C, unless otherwise noted.

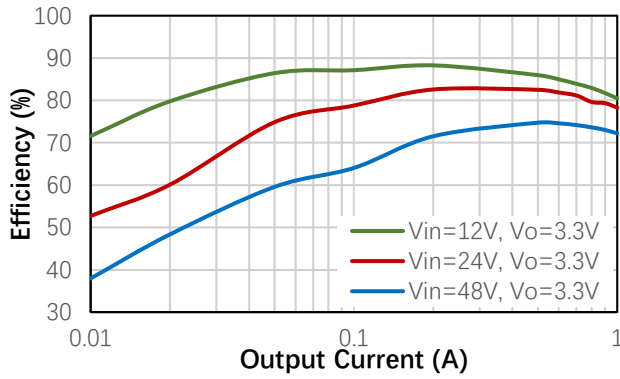

Figure 1. Power Efficiency

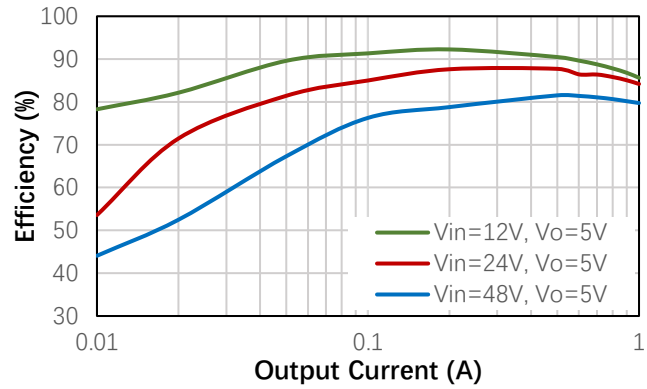

Figure 2. Power Efficiency

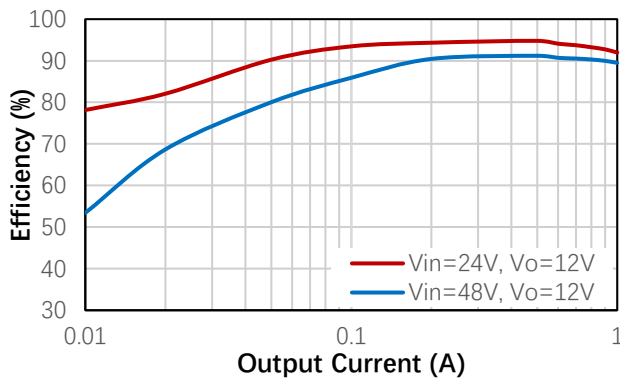

Figure 3. Power Efficiency

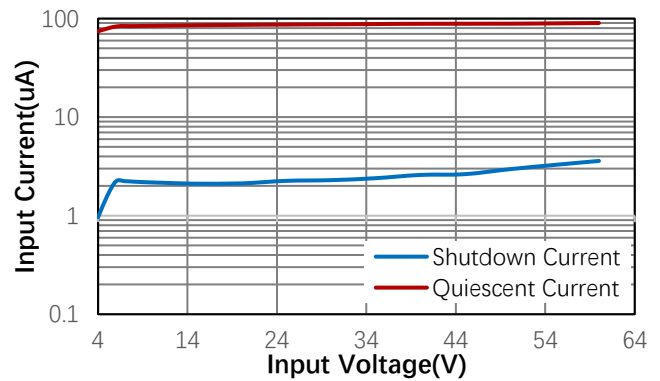

Figure 4. Shut-Down and Quiescent Current

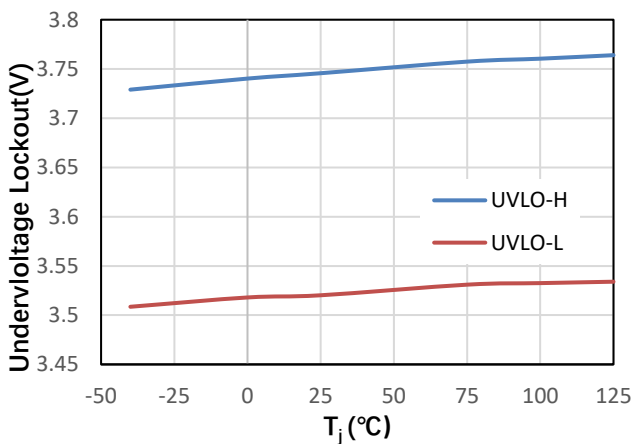

Figure 5. UVLO Vs Junction Temperature

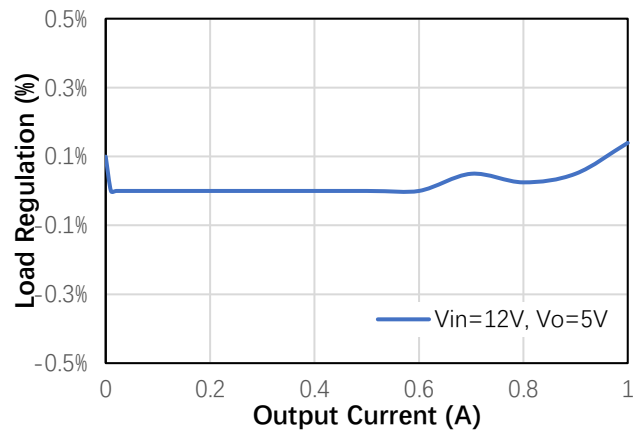
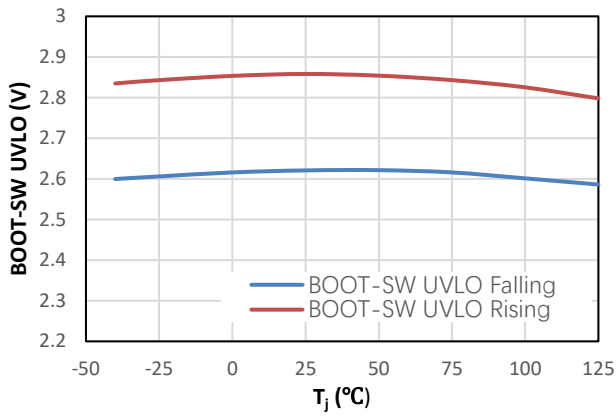
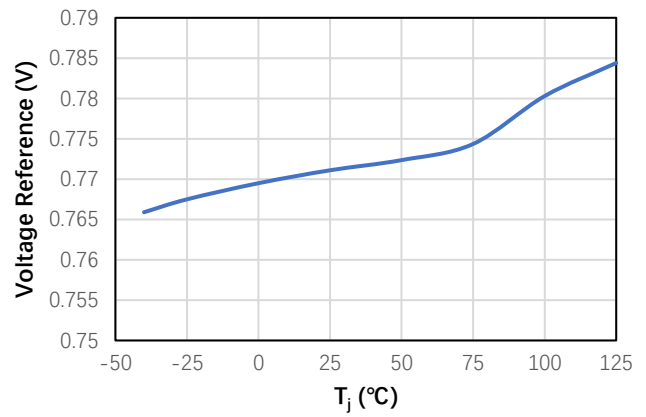

Figure 6. Load Regulation



**Figure 7. BOOT-SW UVLO vs Junction Temperature**



**Figure 8. Voltage Reference Vs Junction Temperature**

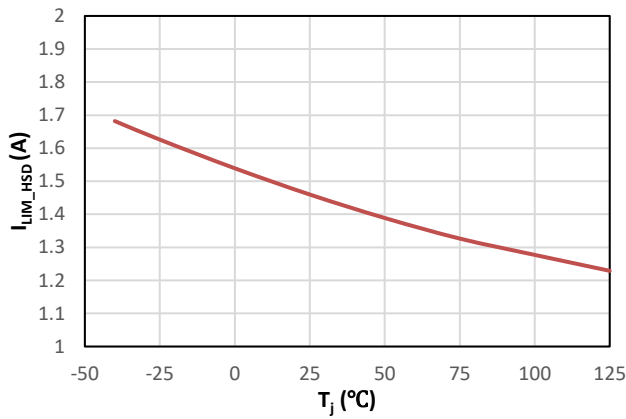

**Figure 9. Switch Current Limit vs Junction Temperature**

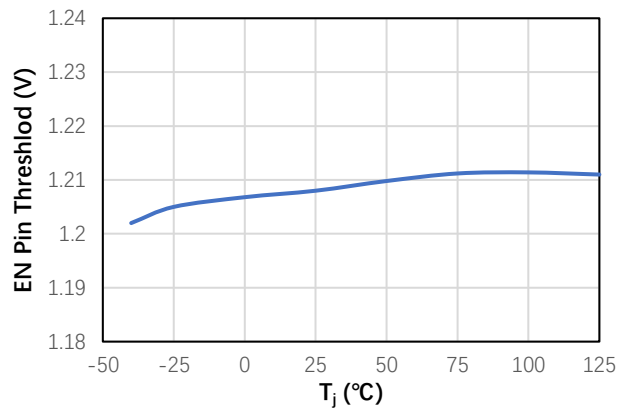

**Figure 10. EN Threshold Vs Junction Temperature**

### FUNCTION BLOCK DIAGRAM

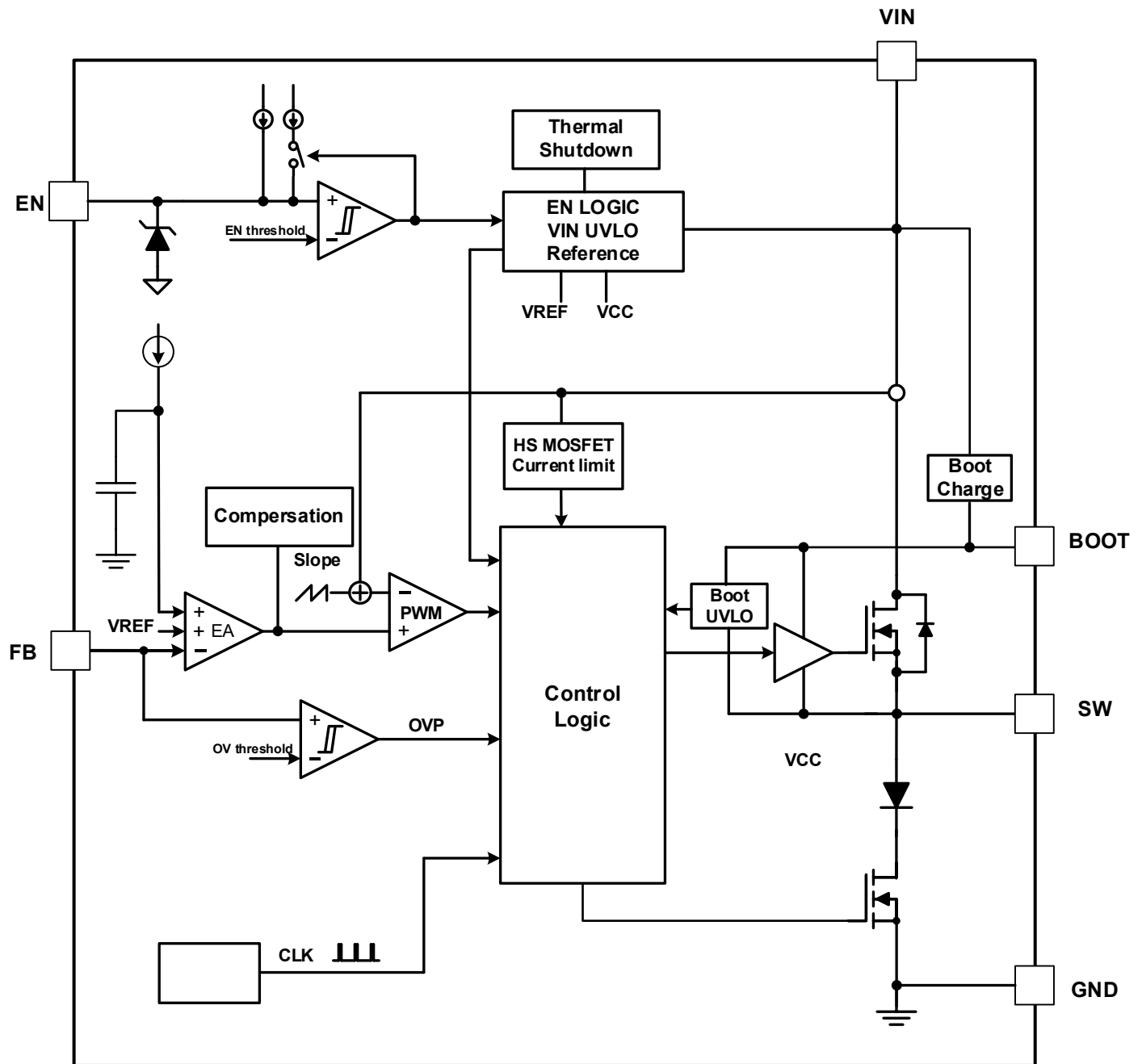

Figure 11. Block Diagram of LMR16006

## DISCRIPTION

### Overview

The LMR16006 is a 60V, 1A buck converter with an integrated 542mΩ high-side MOSFET. With a wide input range from 4V to 60V, the device adopts peak current mode and supports a fixed 600kHz switching frequency to minimize off-chip components. The LMR16006 features an internal 5ms soft-start time.

The quiescent current of this device is 80uA in sleep mode and the shutdown current is 1uA. The device has a default input start-up voltage of 3.75V with 220mV hysteresis. The EN pin is a high-voltage pin with a precision threshold that can be used to adjust the input voltage lockout thresholds with two external resistors to meet accurate higher UVLO system requirements. Floating EN pin enables the device. Connecting EN pin to VIN directly starts up the device automatically when power up.

The device integrates protections, like cycle-by-cycle current limit, thermal shutdown protection, output over-voltage protection and input voltage under-voltage protection. The device also supports monolithic startup with pre-biased output condition.

### Continuous Conduction Mode

The LMR16006 steps the input voltage down to a lower output voltage. In continuous conduction mode (when the inductor current never reaches zero at CCM), the buck regulator operates in two cycles. The power switch is connected between VIN and SW. In the first cycle of operation the transistor is closed and the diode is reverse biased. Energy is collected in the inductor and the load current is supplied by Cout and the rising current through the inductor. During the second cycle the transistor is open and the diode is forward biased due to the fact that the inductor current cannot instantaneously change direction. The energy stored in the inductor is transferred to the load and output capacitor. The ratio of these two cycles determines the output voltage. The output voltage is defined approximately as:  $D = V_{OUT}/V_{IN}$  and  $D' = (1-D)$  where D is the duty cycle of the switch, D and D' will be required for design calculations.

### Pulse Skipping Mode (PSM)

The LMR16006 operates in PSM mode at light load current to improve efficiency by reducing switching and gate drive losses. The LMR16006 is designed so that if the output voltage is within regulation and the peak switch current at the end of any switching cycle is below the sleep current threshold,  $I_{INDUCTOR} \leq 80\text{mA}$ , the device enters PSM mode. For PSM mode operation, the LMR16006 senses peak current, not average or load current, so the load current where the device enters PSM mode is dependent on VIN, VOUT and the output inductor value. When the load current is low and the output voltage is within regulation, the device enters an PSM mode, and draws only 80µA input quiescent current when no loading and no switching.

## Under Voltage Lockout Threshold and Enable

The LMR16006 EN pin is a high voltage tolerant input with an internal pull up circuit. The device can be enabled even if the EN pin is floating. The regulator can also be turned on by using logic signal higher than EN threshold voltage. The maximum voltage to the EN pin should not exceed 60V.

When EN is pulled down to 0V, the chip is turned off and enters the lowest shutdown current mode. In shutdown mode the supply current will be decreased to approximately 1µA.

LMR16006 has an internal Under Voltage Lock Out (UVLO) circuit to shut down the output if the input voltage falls below an internally fixed UVLO threshold level. This ensures that the regulator is not latched into an unknown state during low input voltage conditions. The regulator will power up when the input voltage exceeds the voltage level.

If there is a requirement for a higher UVLO voltage, the EN can be used to adjust the system UVLO by using external resistors. Connect an external resistor divider (RL and RH) shown in Figure 12 from VIN to EN. The UVLO rising and falling threshold can be calculated by Equation 1 and Equation 2 respectively.

$$R_H = \frac{V_{rise} - 1.13 * V_{fall}}{1.13 * 4.0\mu A - 1.0\mu A} \quad (1)$$

$$R_L = \frac{1.21V}{\frac{V_{rise} - 1.21V}{R_H} + 1.0\mu A} \quad (2)$$

where

- $V_{rise}$  is rising threshold of Vin UVLO
- $V_{fall}$  is falling threshold of Vin UVLO

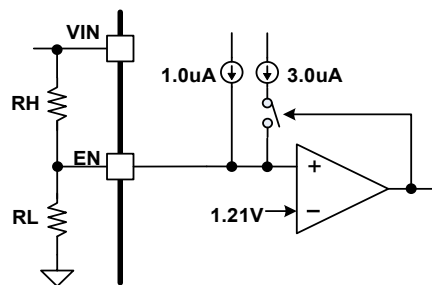

Figure 12. System UVLO by EN divider

## Bootstrap Voltage Regulator

The LMR16006 has an integrated boot regulator, and requires a small ceramic capacitor between the BOOT and SW pins to provide the gate drive voltage for the high side MOSFET. The BOOT capacitor is refreshed when the high side MOSFET is off and the low side diode conducts. To improve drop out, the LMR16006 is designed to operate at 100% duty cycle as long as the BOOT to SW pin voltage is greater than 2.6V. When the voltage from BOOT to SW drops below 2.6V, the high side MOSFET is turned off using an UVLO circuit which allows the low side diode to conduct and refresh the charge on the BOOT capacitor. Since the supply current sourced from the BOOT capacitor is low, the high side MOSFET can remain on for more switching

cycles than are required to refresh the capacitor, thus the effective duty cycle of the switching regulator is high. Attention must be taken in maximum duty cycle applications with light load. To ensure SW can be pulled to ground to refresh the BOOT capacitor, an internal circuit will charge the BOOT capacitor when the load is light or the device is working in dropout condition.

## Output Voltage

The output voltage is set using the feedback pin and a resistor divider connected to the output as shown on the front-page schematic. The feedback pin voltage is 0.770V, so the ratio of the feedback resistors sets the output voltage according to the following equation:  $V_{OUT} = 0.770V (1 + (R1/R2))$ . Typically, R2 will be given as 1k  $\Omega$  - 100 k $\Omega$  for a starting value. To solve for R1 given R2 and Vout uses  $R1 = R2 ((V_{OUT}/0.770V) - 1)$ .

## Overcurrent and Short Circuit Protection

The LMR16006 implements current mode control which uses the internal COMP voltage to turn off the high side MOSFET on a cycle-by-cycle basis. Each cycle the switch current and internal COMP voltage are compared, when the peak switch current intersects the COMP voltage, the high side switch is turned off. During overcurrent conditions that pull the output voltage low, the error amplifier will respond by driving the COMP node high, increasing the switch current. The error amplifier output is clamped internally, which functions as a switch current limit.

## Overvoltage Protection

The LMR16006 incorporates an overvoltage protection (OVP) circuit to minimize voltage overshoot when recovering from output fault conditions or strong unload transients on power supply designs with low value output capacitance. For example, when the power supply output is overloaded the error amplifier compares the actual output voltage to the internal reference voltage. If the FB pin voltage is lower than the internal reference voltage for a considerable time, the output of the error amplifier will respond by clamping the error amplifier output to a high voltage. Thus, requesting the maximum output current. Once the condition is removed, the regulator output rises and the error amplifier output transitions to the steady state duty cycle. In some applications, the power supply output voltage can respond faster than the error amplifier output can respond, this actuality leads to the possibility of an output overshoot. The OVP feature minimizes the output overshoot, when using a low value output capacitor, by implementing a circuit to compare the FB pin voltage to OVP threshold which is 109% of the internal voltage reference. If the FB pin voltage is greater than the OVP threshold, the high side MOSFET is disabled preventing current from flowing to the output and minimizing output overshoot. When the FB voltage drops back lower than the OVP threshold 105%, the high side MOSFET is allowed to turn on at the next clock cycle.

## **Thermal Shutdown**

The LMR16006 features an internal thermal shutdown circuit to protect the device from the damage during excessive heat and power dissipation conditions. The thermal shutdown circuit will be asserted when the junction temperature exceeds typically 160°C. When the junction temperature falls back below 130°C, the device restarts with internal soft start phase.

## APPLICATION INFORMATION

### Typical Application

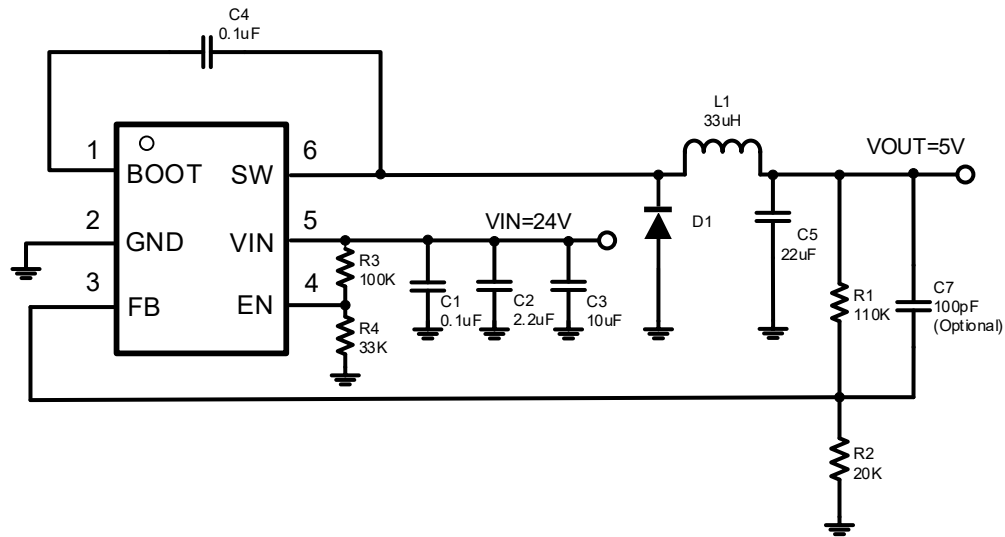

Figure 13. 24V INPUT, 5V/1A OUTPUT

Table 2. Design Parameters

Design Parameters	Example Value
Input Voltage	24V typical, 12V~40V
Output Voltage	5V
Output Current	1A
Output voltage ripple (peak to peak)	<50mV
Overshoot/Undershoot range (0.15~0.45A)	5%
Input Voltage ripple (peak to peak)	<100mV
Switching Frequency	600kHz

## Set Output Voltage

The LMR16006 output voltage can be easily set up using a resistor divider network R1 and R2 as shown in the typical application circuit Figure 9. Use Equation (3) to calculate the resistor divider values.

$$R1 = \frac{(V_{OUT} - 0.770) \times R2}{0.770} \quad (3)$$

In this design for example the  $V_{out}$  is 5V. Set the resistor R2 value to be approximately 20k.

$$R1 = \frac{(V_{OUT} - 0.770) \times R2}{0.770} = \frac{(5 - 0.770) \times 20k\Omega}{0.770} = 109.9k\Omega$$

Slightly increasing or decreasing R1 to a closest available resistance, the 110k $\Omega$  is selected.

## Input Capacitor Selection

For good input voltage filtering, choose low-ESR ceramic capacitors. A X7R ceramic capacitor 4.7 $\mu$ F to 22 $\mu$ F is recommended for the decoupling capacitor and a 0.1 $\mu$ F ceramic bypass capacitor is recommended to be placed as close as possible to the VIN pin. These capacitors must be rated for 50V.

For this design, one 10 $\mu$ F one 2.2 $\mu$ F X7R capacitors and one 0.1 $\mu$ F capacitor rated 50V is recommended.

The input voltage ripple can be calculated by using Equation (4) to calculate the input voltage ripple:

$$\Delta V_{IN} = \frac{I_{OUT}}{C_{IN} \times f_{SW}} \times \frac{V_{OUT}}{V_{IN}} \times \left(1 - \frac{V_{OUT}}{V_{IN}}\right) = \frac{1A}{12.3\mu F \times 600k} \times \frac{5V}{24V} \times \left(1 - \frac{5V}{24V}\right) = 22.3mV \quad (4)$$

Where:

- $C_{IN}$  is the input capacitor value
- $f_{sw}$  is the converter switching frequency
- $I_{OUT}$  is the maximum load current

## Inductor Selection

The performance of inductor affects the power supply's steady state operation, transient behavior, loop stability, and buck converter efficiency. The critical parameters of inductor is the inductance, the DC resistance (DCR), the saturation current and the rated current.

Use following equation to calculate the minimum inductance:

$$L_{MIN} = \frac{V_{OUT} \times (V_{INMAX} - V_{OUT})}{V_{INMAX} \times K_{IND} \times I_{OUT} \times f_{SW}} \quad (5)$$

Where:

- $V_{OUT}$  is output voltage
- $K_{IND}$  is the Ripple Ration of the inductor ripple current ( $\Delta I_L/I_{OUT}$ ), 0.3 is recommended here

- $V_{INMAX}$  is the maximum input voltage
- $f_{SW}$  is the converter switching frequency
- $I_{OUT}$  is the output current

In this design example:

$$L > L_{MIN} = \frac{V_{OUT} \times (V_{INMAX} - V_{OUT})}{V_{INMAX} \times K_{IND} \times I_{OUT} \times f_{SW}} = \frac{5V \times (40V - 5V)}{40V \times 0.3 \times 1A \times 600kHz} = 24.3 \mu H$$

Generally, the Inductor values can have  $\pm 20\%$  or even  $\pm 30\%$  tolerance with no current bias. When the inductor current approaches saturation level, its inductance can decrease 20% to 35% from the value at 0-A current depending on how the inductor vendor defines saturation. When selecting an inductor, choose its rated current especially the saturation current larger than its peak current during the operation.

## Output Capacitor

The output capacitor must be chosen carefully with the reason that this capacitor value determines the regulator pole, the output voltage ripple, and how the regulator responds to a large change in load current. Generally, choose a low-ESR output capacitor like a ceramic capacitor from X5R or X7R family to get small output voltage ripple.

From the required output voltage ripple ( $< 5mV$ ), use the Equation 6 to calculate the minimum required effective capacitance,  $C_{OUT}$ .

$$C_{OUT} > \frac{\Delta I_{LPP}}{8 \times V_{OUT\_Ripple} \times f_{SW}} = \frac{K_{IND} \times I_{OUT}}{8 \times V_{OUT\_Ripple} \times f_{SW}} \quad (6)$$

The allowed maximum ESR of the output capacitor is calculated by the equation 7.

$$R_{ESR} < \frac{V_{OUT\_Ripple}}{k_{IND} \times I_{OUT}} \quad (7)$$

Where

- $V_{OUT\_Ripple}$  is output voltage ripple caused by charging and discharging of the output capacitor.
- $k_{IND}$  is the Ripple Ratio of the inductor ripple current ( $\Delta I_L / I_{OUT}$ ), 0.3 is recommended here
- $I_{OUT}$  is the maximum output current
- $f_{SW}$  is the converter switching frequency.

In this design,  $V_{OUT\_Ripple}$  is smaller than 5mV,  $f_{SW}$  is 600kHz,  $I_{OUT}$  is 1A and  $K_{IND}$  is 0.3:

$$C_{OUT} > \frac{0.3 \times 1A}{8 \times 5mV \times 600k} = 12.5 \mu F$$

$$R_{ESR} < \frac{5mV}{0.3 \times 1A} = 17 m\Omega$$

Therefore, a X7R capacitor of 22uF with 16V DC rating and 15mΩ ESR is selected

### **Bootstrap Capacitor**

For proper operation of the device, a 0.1uF ceramic capacitor of X5R or X7R must be placed between the SW pin to the BOOT pin. The DC rating of this capacitor is must be 10V or higher voltage level.

### **Schottky Diode Selection**

The breakdown voltage rating of the diode is preferred to be 25% higher than the maximum input voltage. In the target application, the current rating for the diode should be equal or greater to the maximum output current for best reliability in most applications. In cases where the input voltage is not much greater than the output voltage the average diode current is lower. In this case it is possible to use a diode with a lower average current rating, approximately  $(1-D) \times I_{OUT}$ . However, the peak current rating should be higher than the maximum load current. A 0.5 A to 1 A rated diode is a good starting point.

## Layout Guideline

Layout is critical for proper operation. Please follow the layout guidelines.

1. The power ground is very critical. The power trace should take lowest impedance as possible and the ground area should be sufficient to optimize thermal, 8mil Max thermal via recommended.
2. Place the bypass input capacitor with low ESR as close as possible to the VIN pin and GND. The bypassing loop from VIN terminal to the GND should be as short as possible.
3. The inductor should be located as close as possible to the SW pin for reducing magnetic and electrostatic noise.
4. The feedback resistor divider should be placed close to the FB pin.
5. The ground connected to the input capacitors and output capacitors should be tied to the system ground plane in only one spot to minimize conducted noise to the system ground plane.

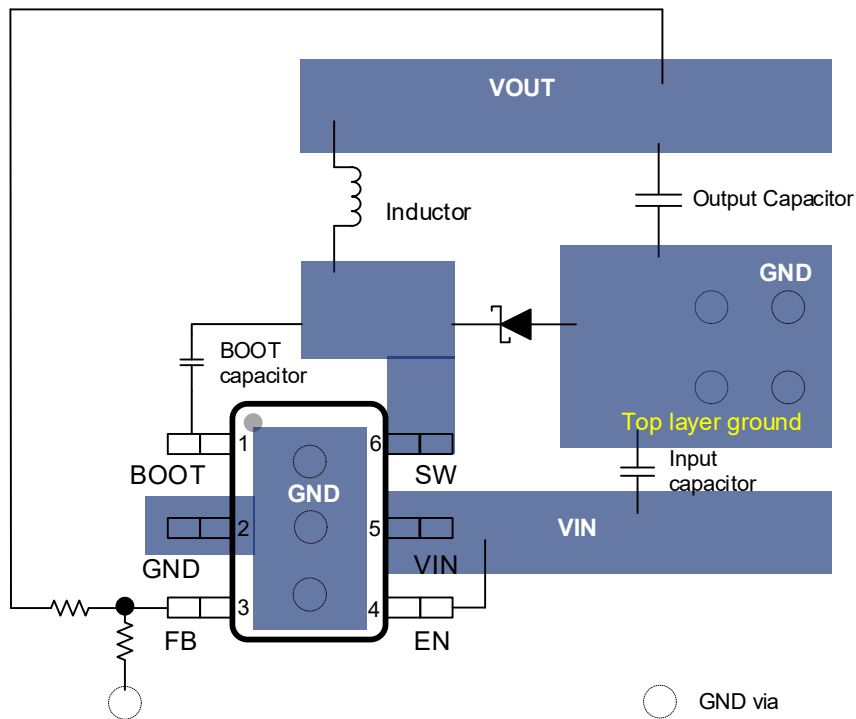
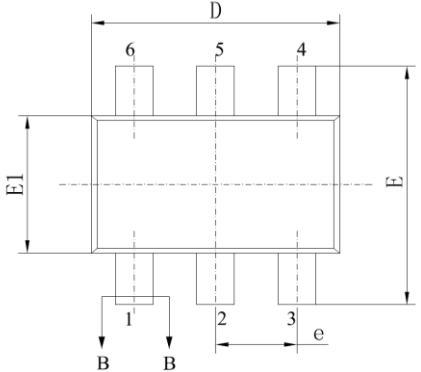
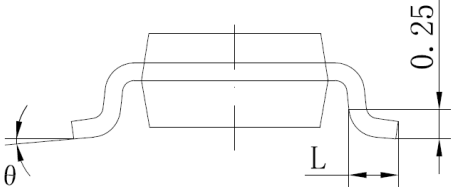
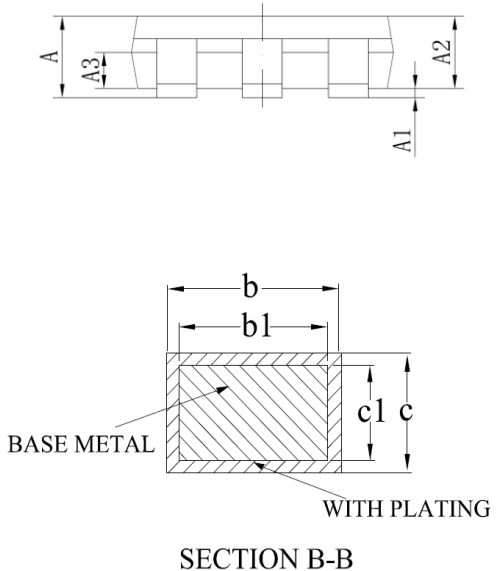

Figure 10. Layout Example

## PACKAGE INFORMATION

																																																																
 <p style="text-align: center;">SECTION B-B</p>	<table border="1"> <thead> <tr> <th rowspan="2">Symbol</th> <th colspan="3">Millimeter</th> </tr> <tr> <th>Min</th> <th>Nor</th> <th>Max</th> </tr> </thead> <tbody> <tr> <td>A</td> <td>-</td> <td>-</td> <td>0.95</td> </tr> <tr> <td>A1</td> <td>0</td> <td>-</td> <td>0.10</td> </tr> <tr> <td>A2</td> <td>0.75</td> <td>0.80</td> <td>0.85</td> </tr> <tr> <td>A3</td> <td>0.35</td> <td>0.40</td> <td>0.45</td> </tr> <tr> <td>b</td> <td>0.38</td> <td>-</td> <td>0.46</td> </tr> <tr> <td>b1</td> <td>0.37</td> <td>0.40</td> <td>0.43</td> </tr> <tr> <td>c</td> <td>0.13</td> <td>-</td> <td>0.17</td> </tr> <tr> <td>c1</td> <td>0.12</td> <td>0.13</td> <td>0.14</td> </tr> <tr> <td>D</td> <td>2.82</td> <td>2.92</td> <td>3.02</td> </tr> <tr> <td>E</td> <td>2.60</td> <td>2.80</td> <td>3.00</td> </tr> <tr> <td>E1</td> <td>1.50</td> <td>1.60</td> <td>1.70</td> </tr> <tr> <td>e</td> <td colspan="3">0.95BSC</td> </tr> <tr> <td>L</td> <td>0.30</td> <td>0.40</td> <td>0.50</td> </tr> <tr> <td><math>\theta</math></td> <td>0</td> <td>-</td> <td>8°</td> </tr> </tbody> </table>	Symbol	Millimeter			Min	Nor	Max	A	-	-	0.95	A1	0	-	0.10	A2	0.75	0.80	0.85	A3	0.35	0.40	0.45	b	0.38	-	0.46	b1	0.37	0.40	0.43	c	0.13	-	0.17	c1	0.12	0.13	0.14	D	2.82	2.92	3.02	E	2.60	2.80	3.00	E1	1.50	1.60	1.70	e	0.95BSC			L	0.30	0.40	0.50	$\theta$	0	-	8°
Symbol	Millimeter																																																															
	Min	Nor	Max																																																													
A	-	-	0.95																																																													
A1	0	-	0.10																																																													
A2	0.75	0.80	0.85																																																													
A3	0.35	0.40	0.45																																																													
b	0.38	-	0.46																																																													
b1	0.37	0.40	0.43																																																													
c	0.13	-	0.17																																																													
c1	0.12	0.13	0.14																																																													
D	2.82	2.92	3.02																																																													
E	2.60	2.80	3.00																																																													
E1	1.50	1.60	1.70																																																													
e	0.95BSC																																																															
L	0.30	0.40	0.50																																																													
$\theta$	0	-	8°																																																													