



Description

The 4N65F can be used in various power switching circuit for system miniaturization and higher efficiency. The package form is TO-220F, which accords with the RoHS standard.

General Features

$V_{DS} = 650V$, $I_D = 4A$

$R_{DS(ON)} < 2.8 @ V_{GS}=10V$

Application

- Power switch circuit of adaptor and charger.

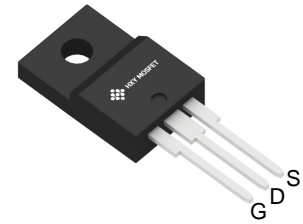

TO-220F

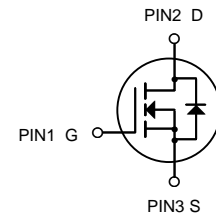

N-Channel MOSFET

Ordering Information

| Product ID | Pack | Brand | Units Tube |
|------------|---------|------------|------------|
| 4N65F | TO-220F | HXY MOSFET | 50 |

Absolute Maximum Ratings @ $T_j=25^{\circ}C$ (unless otherwise specified)

| Symbol | Parameter | Rating | Units |
|--------------------------|--|------------|-------------|
| V_{DS} | Drain-Source Voltage | 650 | V |
| V_{GS} | Gate-Source Voltage | ± 30 | V |
| $I_D @ T_C=25^{\circ}C$ | Drain Current, $V_{GS} @ 10V$ | 4 | A |
| $I_D @ T_C=100^{\circ}C$ | Drain Current, $V_{GS} @ 10V$ | 2.5 | A |
| IDM | Pulsed Drain Current ¹ | 16 | A |
| $P_D @ T_C=25^{\circ}C$ | Total Power Dissipation | 30 | W |
| E_{AS} | Single Pulse Avalanche Energy ⁴ | 200 | mJ |
| TSTG | Storage Temperature Range | -55 to 150 | $^{\circ}C$ |
| T_J | Operating Junction Temperature Range | -55 to 150 | $^{\circ}C$ |



Electrical Characteristics (Tc= 25°C unless otherwise specified):

| OFF Characteristics | | | | | | |
|------------------------------|-----------------------------------|---|--------|------|------|---------|
| Symbol | Parameter | Test Conditions | Rating | | | Units |
| | | | Min. | Typ. | Max. | |
| V_{DSS} | Drain to Source Breakdown Voltage | $V_{GS}=0V, I_D=250\mu A$ | 650 | -- | -- | V |
| $\Delta BV_{DSS}/\Delta T_J$ | Bvdss Temperature Coefficient | ID=250uA, Reference 25°C | -- | 0.67 | -- | V/°C |
| I_{DSS} | Drain to Source Leakage Current | $V_{DS}=650V, V_{GS}=0V, T_a=25^\circ C$ | -- | -- | 1 | μA |
| | | $V_{DS}=520V, V_{GS}=0V, T_a=125^\circ C$ | -- | -- | 100 | μA |
| $I_{GSS(F)}$ | Gate to Source Forward Leakage | $V_{GS}=+30V$ | -- | -- | 100 | nA |
| $I_{GSS(R)}$ | Gate to Source Reverse Leakage | $V_{GS}=-30V$ | -- | -- | -100 | nA |

| ON Characteristics | | | | | | |
|--|-------------------------------|-------------------------------|--------|------|------|----------|
| Symbol | Parameter | Test Conditions | Rating | | | Units |
| | | | Min. | Typ. | Max. | |
| $R_{DS(ON)}$ | Drain-to-Source On-Resistance | $V_{GS}=10V, I_D=2A$ | -- | 2.4 | 2.8 | Ω |
| $V_{GS(TH)}$ | Gate Threshold Voltage | $V_{DS}=V_{GS}, I_D=250\mu A$ | 2.0 | -- | 4.0 | V |
| Pulse width $t_p \leq 300\mu s, \delta \leq 2\%$ | | | | | | |

| Dynamic Characteristics | | | | | | |
|-------------------------|------------------------------|-----------------------------------|--------|------|------|-------|
| Symbol | Parameter | Test Conditions | Rating | | | Units |
| | | | Min. | Typ. | Max. | |
| g_{fs} | Forward Transconductance | $V_{DS}=15V, I_D=2A$ | -- | 3.5 | -- | S |
| C_{iss} | Input Capacitance | $V_{GS}=0V, V_{DS}=25V, f=1.0MHz$ | -- | 610 | -- | pF |
| C_{oss} | Output Capacitance | | -- | 53 | -- | |
| C_{rss} | Reverse Transfer Capacitance | | -- | 3.5 | -- | |

| Resistive Switching Characteristics | | | | | | |
|-------------------------------------|---------------------------------|-------------------------------------|--------|------|------|-------|
| Symbol | Parameter | Test Conditions | Rating | | | Units |
| | | | Min. | Typ. | Max. | |
| $t_{d(ON)}$ | Turn-on Delay Time | $I_D=4A, V_{DD}=325V, R_G=10\Omega$ | -- | 14 | -- | ns |
| t_r | Rise Time | | -- | 16 | -- | |
| $t_{d(OFF)}$ | Turn-Off Delay Time | | -- | 32 | -- | |
| t_f | Fall Time | | -- | 11 | -- | |
| Q_g | Total Gate Charge | $I_D=4A, V_{DD}=520V, V_{GS}=10V$ | -- | 14.5 | -- | nC |
| Q_{gs} | Gate to Source Charge | | -- | 3 | -- | |
| Q_{gd} | Gate to Drain ("Miller") Charge | | -- | 6.5 | -- | |



| Source-Drain Diode Characteristics | | | | | | |
|--|--|---|--------|------|------|-------|
| Symbol | Parameter | Test Conditions | Rating | | | Units |
| | | | Min. | Typ. | Max. | |
| I_S | Continuous Source Current (Body Diode) | | -- | -- | 4 | A |
| I_{SM} | Maximum Pulsed Current (Body Diode) | | -- | -- | 16 | A |
| V_{SD} | Diode Forward Voltage | $I_S=4.0A, V_{GS}=0V$ | -- | -- | 1.5 | V |
| t_{rr} | Reverse Recovery Time | $I_S=4.0A, T_J = 25^\circ C$ $dI_F/dt=100A/us,$ $V_{GS}=0V$ | -- | 256 | -- | ns |
| Q_{rr} | Reverse Recovery Charge | | -- | 1200 | -- | nC |
| I_{RRM} | Reverse Recovery Current | | -- | 9.4 | -- | A |
| Pulse width $t_p \leq 300\mu s, \delta \leq 2\%$ | | | | | | |

| Symbol | Parameter | Typ. | Units |
|-----------------|---------------------|------|--------------|
| $R_{\theta JC}$ | Junction-to-Case | 4.17 | $^\circ C/W$ |
| $R_{\theta JA}$ | Junction-to-Ambient | 62.5 | $^\circ C/W$ |

^{a1}: Repetitive rating; pulse width limited by maximum junction temperature

^{a2}: $L=10mH, I_D=6.3A, Start T_J=25^\circ C$

^{a3}: $I_{SD}=4A, di/dt \leq 100A/us, V_{DD} \leq BV_{DS}, Start T_J=25^\circ C$



Characteristics Curve

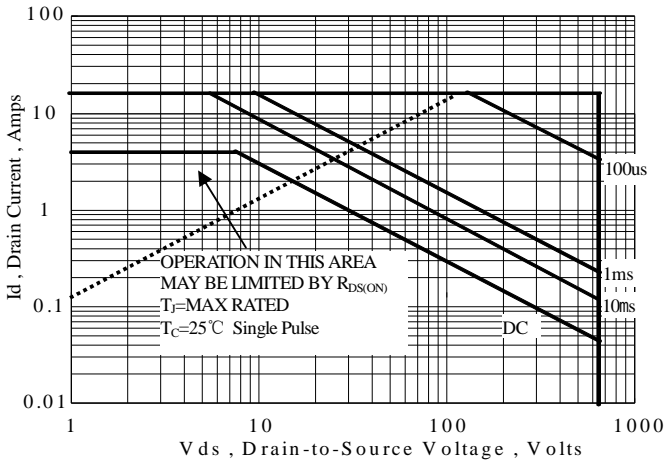

Figure 1 Maximum Forward Bias Safe Operating Area

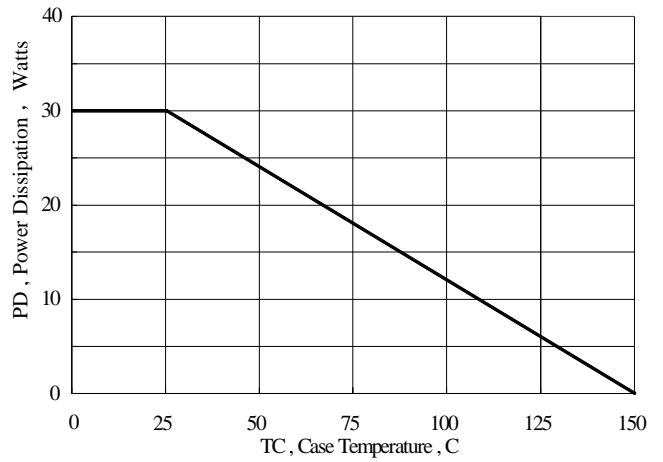

Figure 2 Maximum Power Dissipation vs Case Temperature

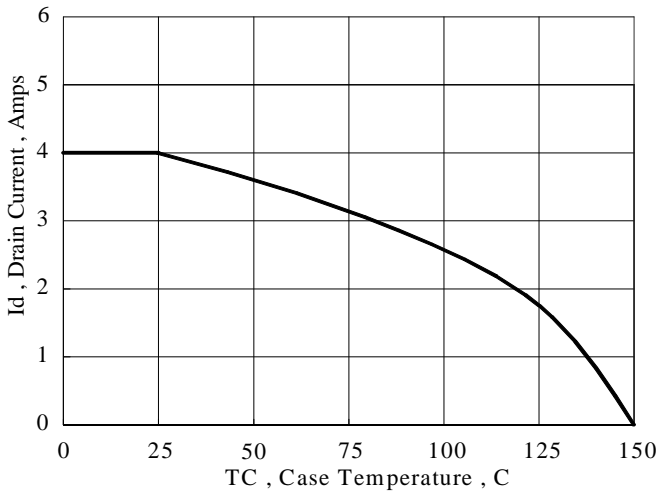

Figure 3 Maximum Continuous Drain Current vs Case Temperature

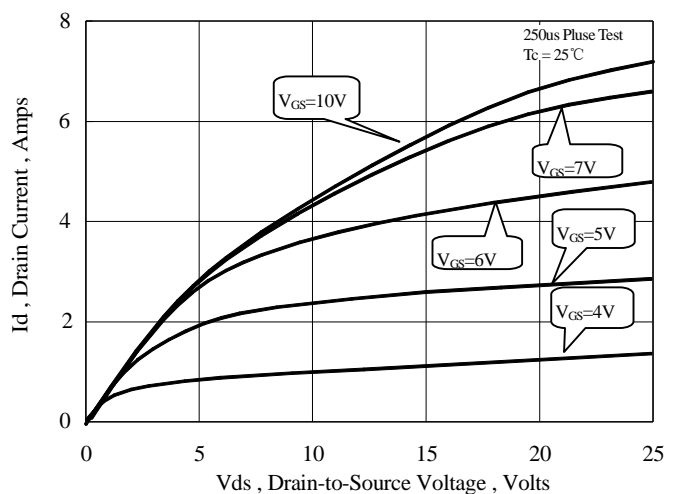

Figure 4 Typical Output Characteristics

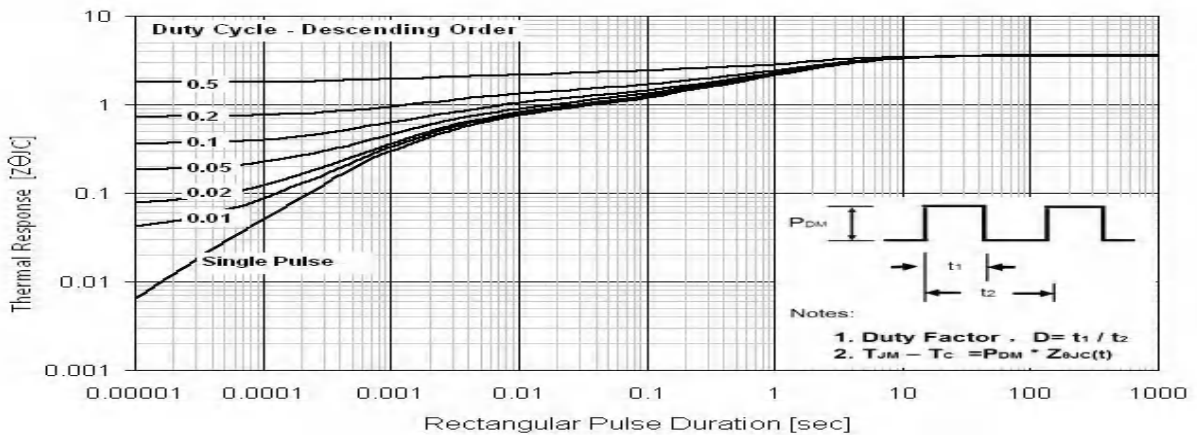

Figure 5 Maximum Effective Thermal Impedance, Junction to Case

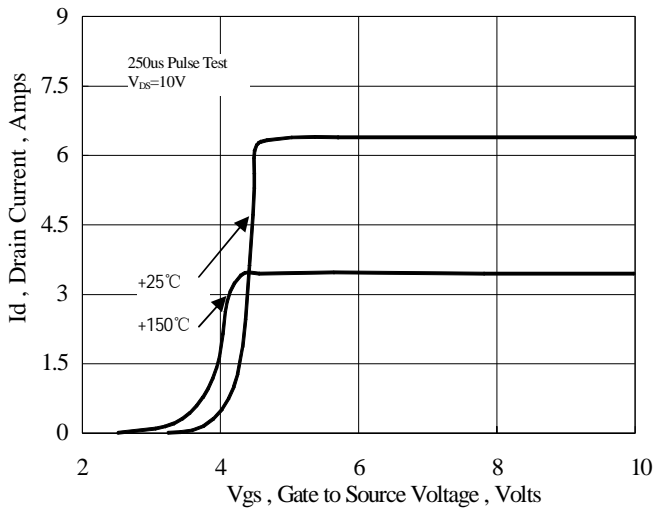

Figure 6 Typical Transfer Characteristics

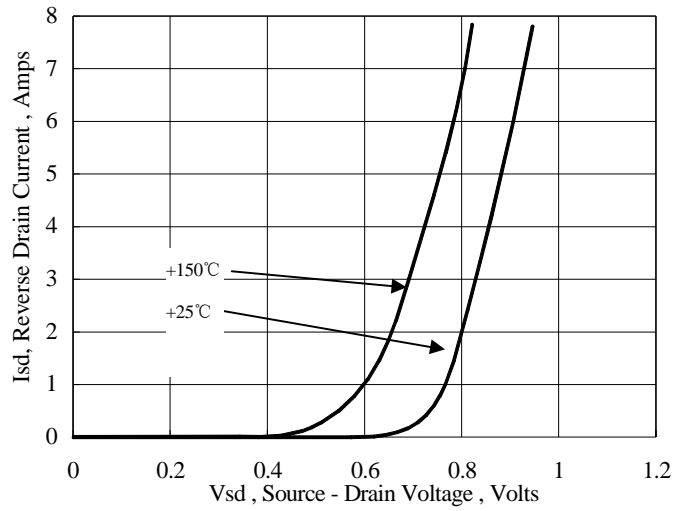

Figure 7 Typical Body Diode Transfer Characteristics

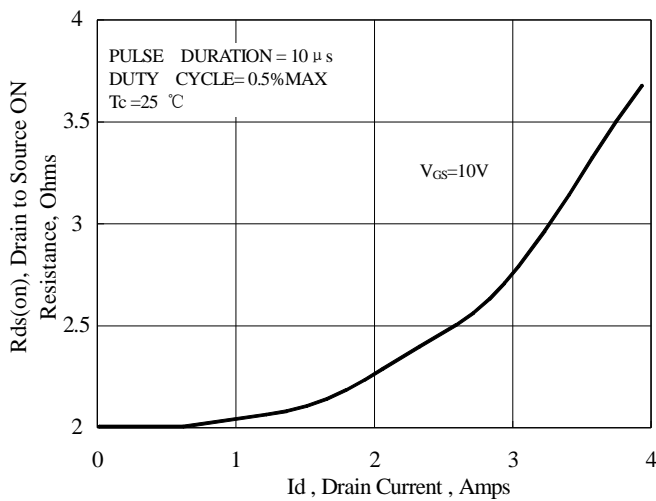

Figure 8 Typical Drain to Source ON Resistance vs Drain Current

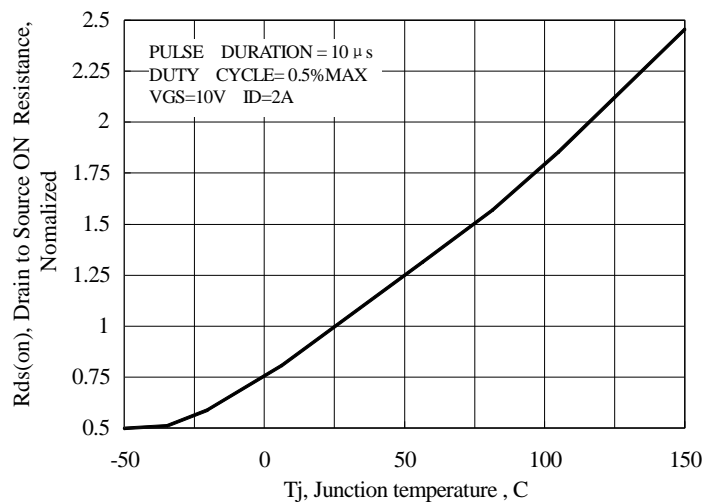

Figure 9 Typical Drain to Source on Resistance vs Junction Temperature

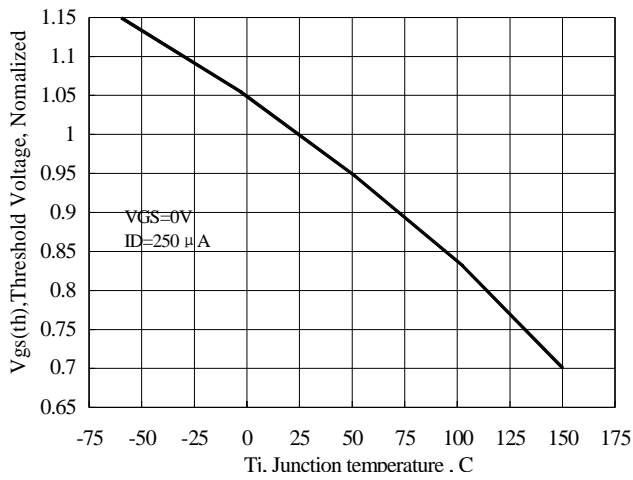

Figure 10 Typical Theshold Voltage vs Junction Temperature

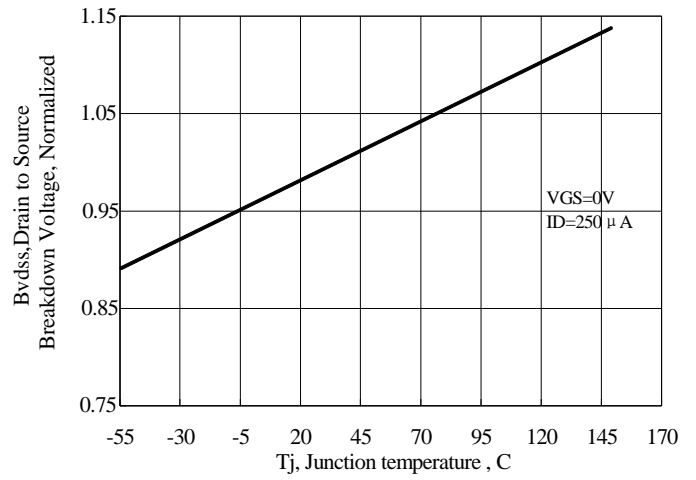

Figure 11 Typical Breakdown Voltage vs Junction Temperature

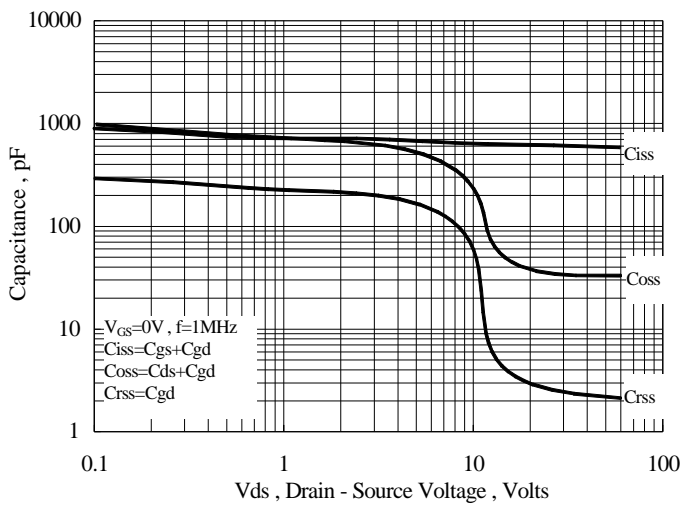

Figure 12 Typical Capacitance vs Drain to Source Voltage

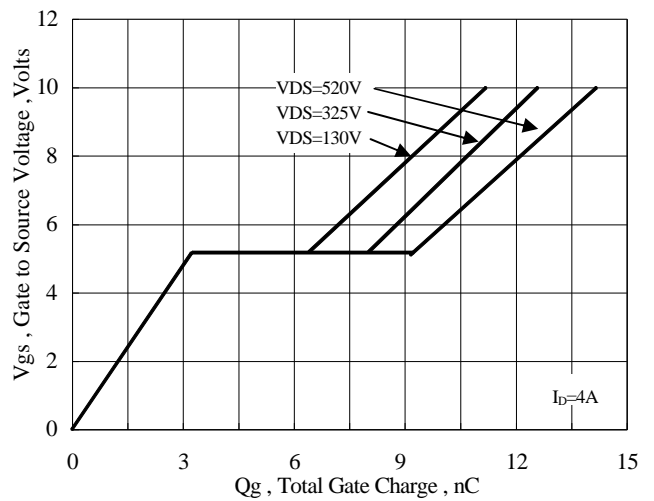

Figure 13 Typical Gate Charge vs Gate to Source Voltage



Test Circuit and Waveform

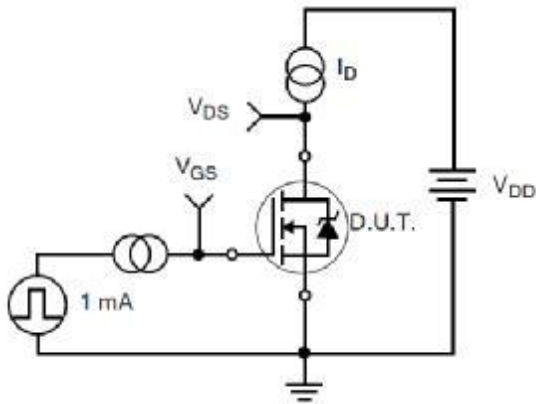

Figure 17. Gate Charge Test Circuit

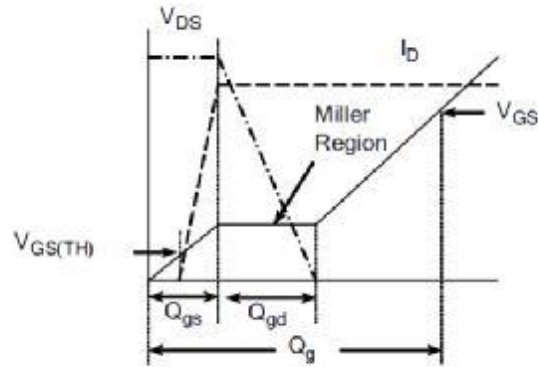

Figure 18. Gate Charge Waveform

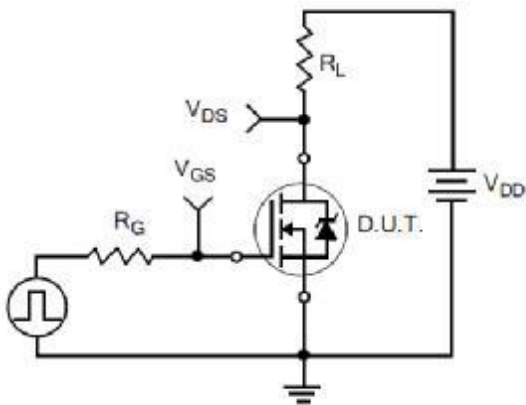

Figure 19. Resistive Switching Test Circuit

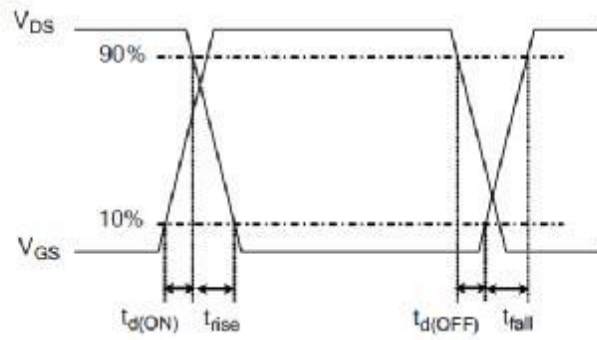

Figure 20. Resistive Switching Waveforms

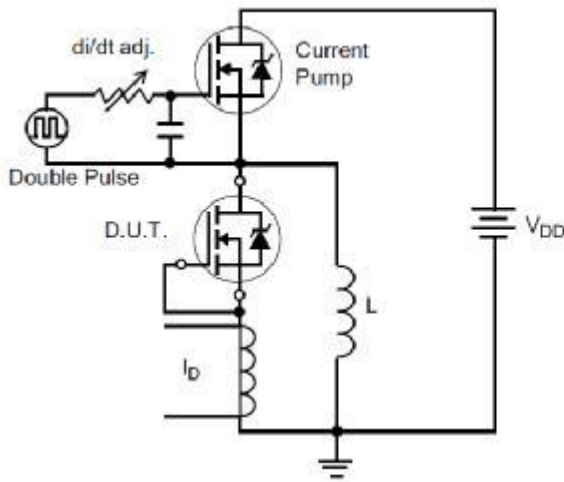

Figure 21. Diode Reverse Recovery Test Circuit

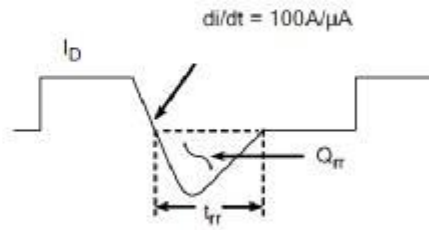

Figure 22. Diode Reverse Recovery Waveform

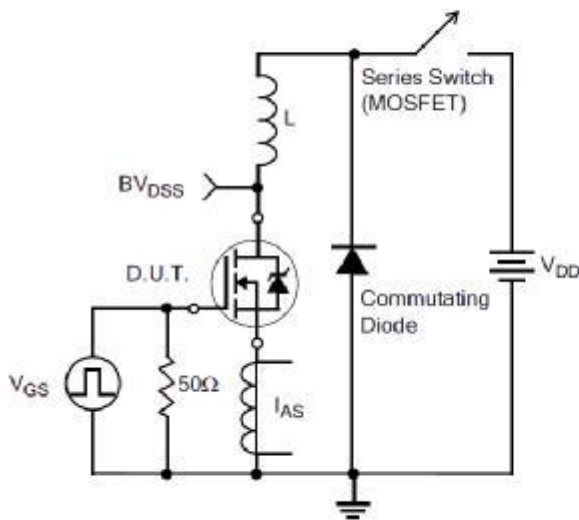

Figure 23. Unclamped Inductive Switching Test Circuit

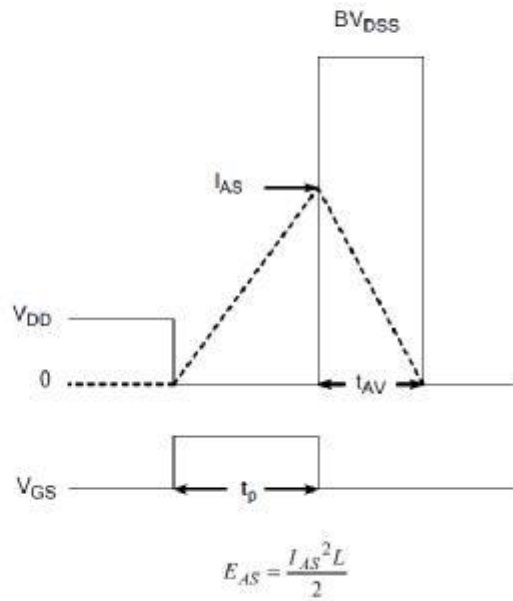
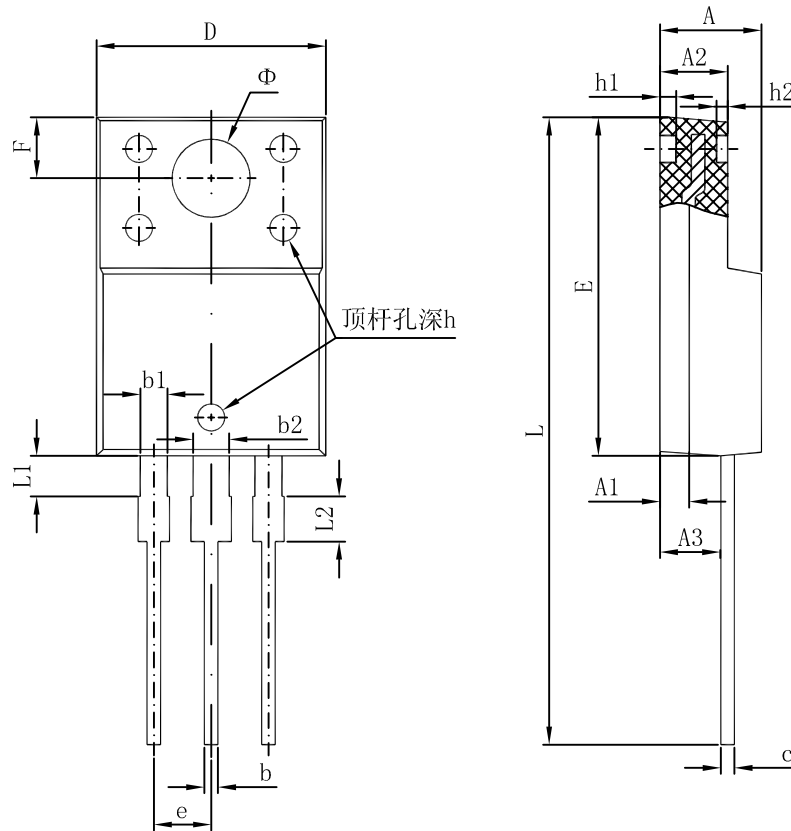

Figure 24. Unclamped Inductive Switching Waveforms



Package Information
TO-220F



| Symbol | Dimensions In Millimeters | | Dimensions In Inches | |
|--------|---------------------------|--------|----------------------|-------|
| | Min. | Max. | Min. | Max. |
| A | 4.300 | 4.700 | 0.169 | 0.185 |
| A1 | 1.300 REF. | | 0.051 REF. | |
| A2 | 2.800 | 3.200 | 0.110 | 0.126 |
| A3 | 2.500 | 2.900 | 0.098 | 0.114 |
| b | 0.500 | 0.750 | 0.020 | 0.030 |
| b1 | 1.100 | 1.350 | 0.043 | 0.053 |
| b2 | 1.500 | 1.750 | 0.059 | 0.069 |
| c | 0.500 | 0.750 | 0.020 | 0.030 |
| D | 9.960 | 10.360 | 0.392 | 0.408 |
| E | 14.800 | 15.200 | 0.583 | 0.598 |
| e | 2.540 TYP. | | 0.100 TYP. | |
| F | 2.700 REF. | | 0.106 REF. | |
| Φ | 3.500 REF. | | 0.138 REF. | |
| h | 0.000 | 0.300 | 0.000 | 0.012 |
| h1 | 0.800 REF. | | 0.031 REF. | |
| h2 | 0.500 REF. | | 0.020 REF. | |
| L | 28.000 | 28.400 | 1.102 | 1.118 |
| L1 | 1.700 | 1.900 | 0.067 | 0.075 |
| L2 | 1.900 | 2.100 | 0.075 | 0.083 |



Attention

- Any and all HUA XUAN YANG ELECTRONICS products described or contained herein do not have specifications that can handle applications that require extremely high levels of reliability, such as life-support systems, aircraft's control systems, or other applications whose failure can be reasonably expected to result in serious physical and/or material damage. Consult with your HUA XUAN YANG ELECTRONICS representative nearest you before using any HUA XUAN YANG ELECTRONICS products described or contained herein in such applications.
- HUA XUAN YANG ELECTRONICS assumes no responsibility for equipment failures that result from using products at values that exceed, even momentarily, rated values (such as maximum ratings, operating condition ranges, or other parameters) listed in products specifications of any and all HUA XUAN YANG ELECTRONICS products described or contained herein.
- Specifications of any and all HUA XUAN YANG ELECTRONICS products described or contained herein stipulate the performance, characteristics, and functions of the described products in the independent state, and are not guarantees of the performance, characteristics, and functions of the described products as mounted in the customer's products or equipment. To verify symptoms and states that cannot be evaluated in an independent device, the customer should always evaluate and test devices mounted in the customer's products or equipment.
- HUA XUAN YANG ELECTRONICS CO.,LTD. strives to supply high-quality high-reliability products. However, any and all semiconductor products fail with some probability. It is possible that these probabilistic failures could give rise to accidents or events that could endanger human lives, that could give rise to smoke or fire, or that could cause damage to other property. When designing equipment, adopt safety measures so that these kinds of accidents or events cannot occur. Such measures include but are not limited to protective circuits and error prevention circuits for safe design, redundant design, and structural design.
- In the event that any or all HUA XUAN YANG ELECTRONICS products(including technical data, services) described or contained herein are controlled under any of applicable local export control laws and regulations, such products must not be exported without obtaining the export license from the authorities concerned in accordance with the above law.
- No part of this publication may be reproduced or transmitted in any form or by any means, electronic or mechanical, including photocopying and recording, or any information storage or retrieval system, or otherwise, without the prior written permission of HUA XUAN YANG ELECTRONICS CO.,LTD.
- Information (including circuit diagrams and circuit parameters) herein is for example only ; it is not guaranteed for volume production. HUA XUAN YANG ELECTRONICS believes information herein is accurate and reliable, but no guarantees are made or implied regarding its use or any infringements of intellectual property rights or other rights of third parties.
- Any and all information described or contained herein are subject to change without notice due to product/technology improvement, etc. When designing equipment, refer to the "Delivery Specification" for the HUA XUAN YANG ELECTRONICS product that you intend to use.