

WITH PICK UP COVER
SCALE 1:2

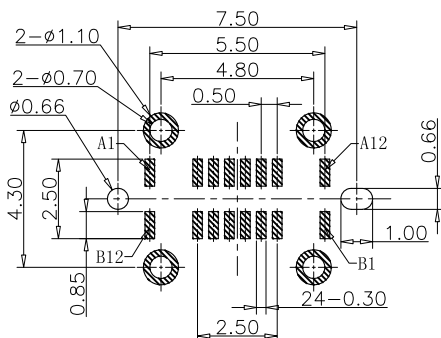

RECOMMEND P.C.B LAYOUT (COMPONENT SIDE)
TOLERANCE FOR PCB LAYOUT IS ±0.05

REV. (版本号)	DESCRIPTION (变更说明)	DATE (日期)	APPD (核准)
A0	新订图面	2022.02.14	Yuxiang

- NOTES:
SPECIFICATION:
1. CURRENT RATING: 5.0 A
2. VOLTAGE RATING: 5.0 V
3. VBUS & GND PINS AND OTHER PINS: 40mΩ/PIN MAX
SHIELD: 50mΩ/MAX
LLCR MAX. CHANGE OF ALL PINS: 10Ωm
4. INSULATION RESISTANCE: 100MΩ MIN
5. DIELECTRIC WITHSTAND VOLTAGE, AC 100V FOR 1MINUTE
6. INSERTION FORCE: 0.5~2.0kgf
7. UNMATING FORCE: 0.8~2.0kgf
8. DURABILITY: 10000 CYCLES
9. OPERATING TEMPERATURE: -25°C~+85°C
10. THE PEAK TEMPERATURE ON THE BOARD SHALL BE MAINTAINED FOR 10 SECONDS AT 260°C

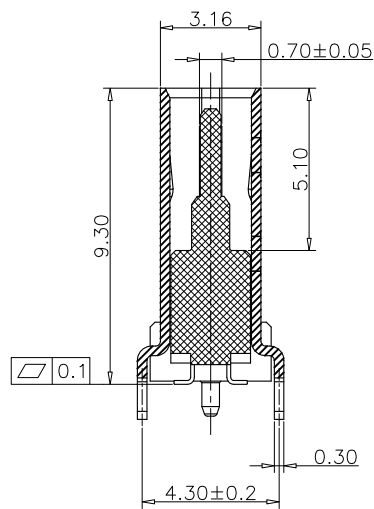
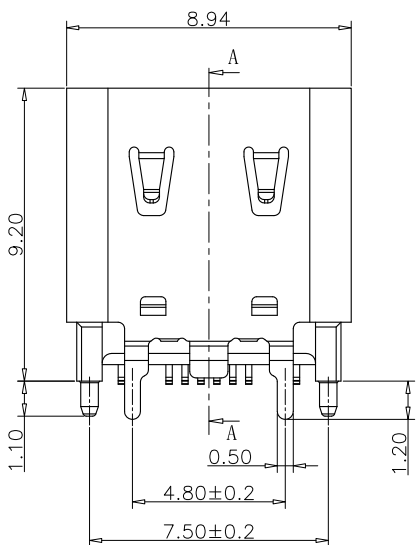

SECTION A-A
SCALE 1:1

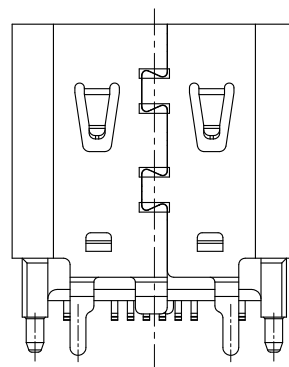

USB TYPE C PIN ASSIGNMENTS

PIN NUMBER	SIGNAL NAME	PIN NUMBER	SIGNAL NAME
A1	GND	B12	GND
A4	VBUS	B9	VBUS
A5	CC1	B8	SBU2
A6	DP1	B7	DN2
A7	DN1	B6	DP2
A8	SBU1	B5	CC2
A9	VBUS	B4	VBUS
A12	GND	B1	GND

TABLE:

NO	PART	Q'TY	Material
1	SHELL	1	STAINLESS STEEL, NI PLATED
2	CONTACT	16	COPPER ALLOY, TIN/AU/NI PLATED
3	MID PLATE	1	STAINLESS STEEL, NO PLATING
4	HOUSING	1	HIGH TEMPERATURE RESISTANT PLASTIC BLACK UL94 V-0

外壳 (1A-1)

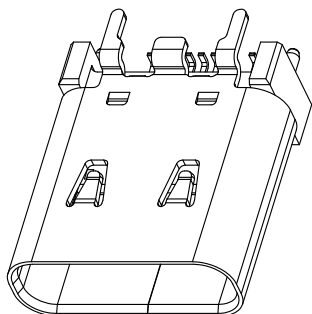
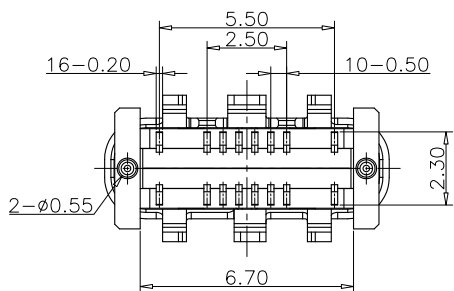

深圳市宇文发电子科技有限公司 Shen Zhen Yu Wen Fa Electronics Technology Co., Ltd TEL: 0755-27711235 FAX: 0755-27712683		页码 (SHEET)	1/1	单位 (UNIT): MM
品名 (ITEM NO)		TYPE C 16P 立式母座 9.3	版本 (REV)	A0
料号 (PART NO)		PTCFW-R12E-006	日期 (DATE)	2022.02.15
图号 (DWG NO)		P-TCF-075	设计 (DESIGN)	Yuxiang
			审核 (CHECKED)	
			核准 (APPROVED)	

TOLERANCE UNSPECIFIED	
X.X	±0.30
X.XX	±0.20
X.XXX	±0.10
X°	±5°
X.X°	±2°

REV.	ECN NO	DESCRIPTION	REVISER	DATE
A/0				
A/1				

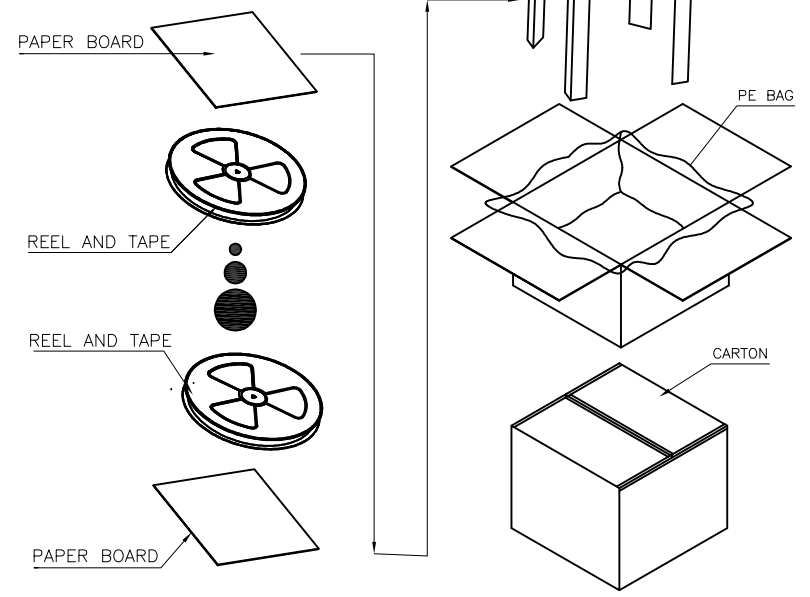
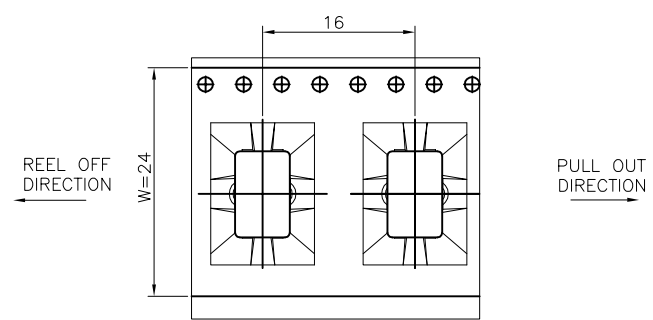
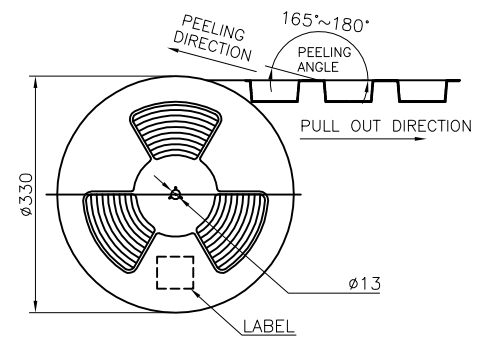
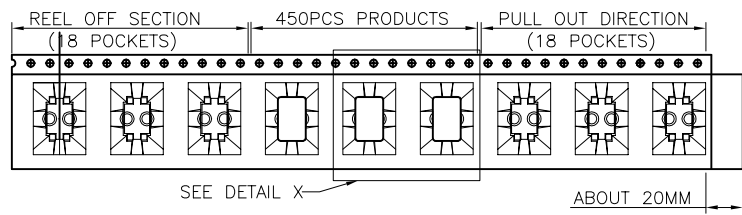

备注:

- 包材规格:
蓝色卷盘: $\varnothing 380 \times W24\text{mm}$
卷带: (486PCS空格/卷).
三角纸板: $100 \times 140 \times 100\text{mm}$, $H=315\text{mm}$, $K=K$
自粘上带: $W=21.3\text{mm}$, $T=0.08\text{mm}$
PE袋: $T0.007 \times W65 \times H65\text{CM}$
外箱: $400 \times 400 \times 32\text{cm}$
- 将产品依上图所示装入载带中. 前留18PCS空格. 后留18个空格.
再将自粘上带与载带粘好, 注意不可封孔, 上带需比载带长至少300mm,
然后用80-150mm美纹胶固定; 450pcs/卷盘, 每卷盘都需贴卷盘物料标签.
- 将10个卷盘放入1个大PE防水袋, 装入外箱时需装入护角纸板.
- 每个外箱装10卷盘, 共计4.5Kpcs/箱.
- 将装好产品外箱用透明胶带封成“工”形, 并在外箱左上角贴HF标签,
物料标识区分用的“外箱标签”.

	REEL	CARTON
CONNECTOR (PCS)	450	4500

图号 (DWG NO)	单位 (UNIT): MM	深圳市宇文发电子科技有限公司 Shen Zhen Yu Wen Fa Electronics Technology Co., Ltd TEL: 0755-27711235 FAX: 0755-27712683		
日期 (DATE)	2021. 07. 24			
版次 (REV): A/0	页/次(PAGE): 1/1			
设计 (DESIGN)	ZHUANG	包装规范	品名 (ITEM NO)	TYPE C 24P立式母座-包装规范
审核 (CHECKED)			料号 (PART NO)	A-004R-087
核准 (APPROVED)				