

1. DESCRIPTION

The XL285-1.2,XT285-1.2,XL385-1.2,XT385-1.2,XB385M3-1.2 are micropower 2-terminal band-gap voltage regulator diodes. Operating over a 10 μ A to 20mA current range, they feature exceptionally low dynamic impedance and good temperature stability. On-chip trimming is used to provide tight voltage tolerance.

2. FEATURES

- $\pm 1\%$ and 2% Initial Tolerance
- Operating Current of 10 μ A to 20mA
- 1 Ω Dynamic Impedance
- Low Temperature Coefficient
- Low Voltage Reference—1.235V

3. CONNECTION DIAGRAM

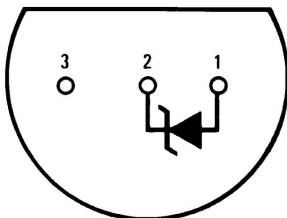

Figure 1. T0-92

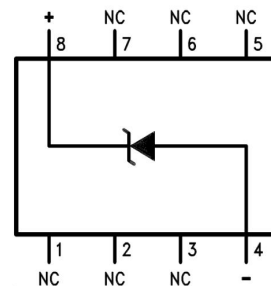
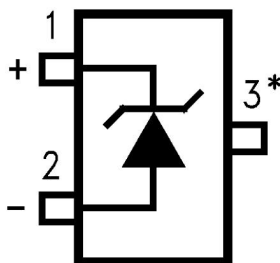

Figure 3. SOP8



* Pin 3 is attached to the Die Attach Pad (DAP) and should be connected to Pin 2 or left floating.

Figure 2. SOT23-3

4. ELECTRICAL CHARACTERISTICS

Parameter	Conditions	Typ	XL385-1.2		XL385-1.2		XL385-1.2		Units (Limit)
			Tested Limit ⁽²⁾ ⁽³⁾	Design Limit ⁽⁴⁾	Tested Limit ⁽²⁾	Design Limit ⁽⁴⁾	Tested Limit ⁽²⁾	Design Limit ⁽⁴⁾	
Reverse Breakdown Voltage	T _A = 25°C, 10μA ≤ I _R ≤ 20mA	1.23 5	1.223		1.223		1.205		V(Min)
			1.247		1.247		1.260		V(Max)
Minimum Operating Current		8	10	20	15	20	15	20	μA
	XL385-1.2						10	15	(Max)
Reverse Breakdown Voltage Change with Current	10μA ≤ I _R ≤ 1mA		1	1.5	1	1.5	1	1.5	mV (Max)
	1mA ≤ I _R ≤ 20mA		10	20	20	25	20	25	mV (Max)
Reverse Dynamic Impedance	I _R = 100μA, f = 20Hz	1							Ω
Wideband Noise (rms)	I _R = 100μA, 10Hz ≤ f ≤ 10kHz	60							μV
Long Term Stability	I _R = 100μA, T = 1000 Hr, T _A = 25°C ±0.1°C	20							ppm
Average Temperature Coefficient ⁽⁵⁾	I _R = 100μA								
	X Suffix		30		30				ppm/°C
	Y Suffix		50		50				ppm/°C
	All Others			150		150		150	ppm/°C (Max)

- (1) Parameters identified with boldface type apply at temperature extremes. All other numbers apply at T_A = T_J = 25°C.
(2) Production tested.
(3) Specified by design. Not production tested. These limits are not used to calculate average outgoing quality levels.
(4) The average temperature coefficient is defined as the maximum deviation of reference voltage at all measured temperatures between the operating T_{MAX} and T_{MIN}, divided by T_{MAX} - T_{MIN}. The measured temperatures are -55°C, -40°C, 0°C, 25°C, 70°C, 85°C, 125°C.

5. THERMAL CHARACTERISTICS

Thermal Resistance	TO-92	SOP	SOT-23
θ _{JA} (junction to ambient)	180°C/W (0.4" leads) 170°C/W (0.125" leads)	165°C/W	283°C/W
θ _{JC} (junction to case)	N/A	N/A	N/A

6. TYPICAL PERFORMANCE CHARACTERISTICS

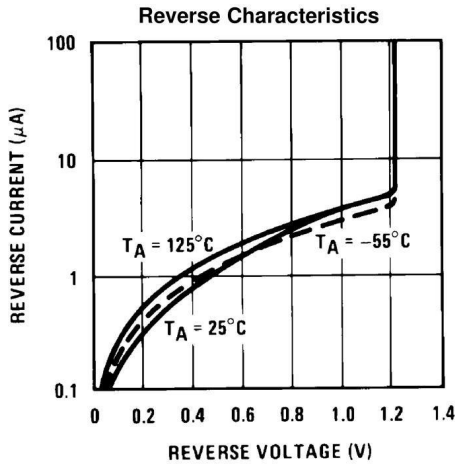

Figure 4.

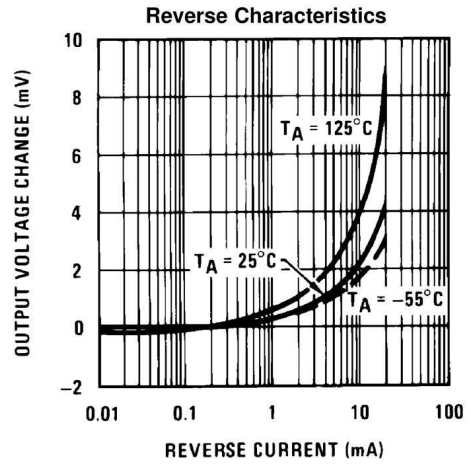

Figure 5.

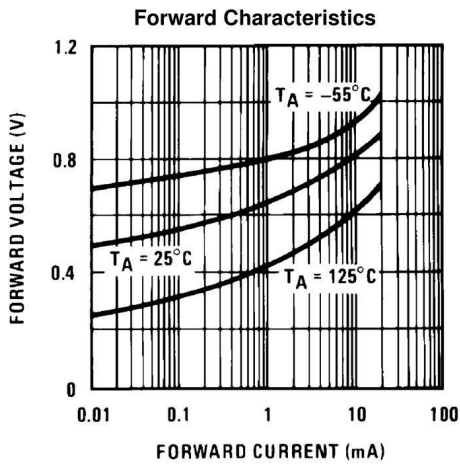

Figure 6.

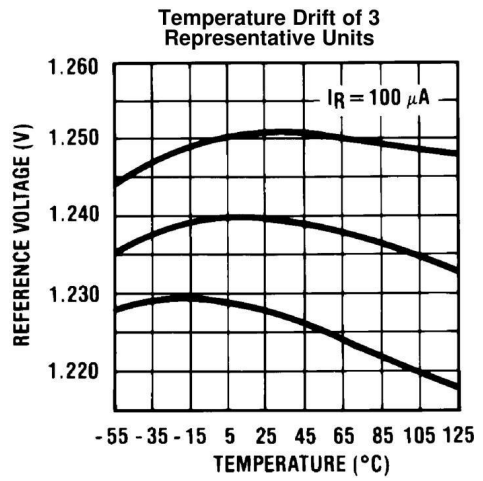

Figure 7.

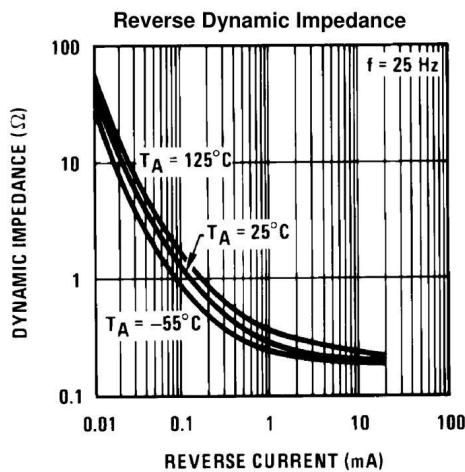

Figure 8.

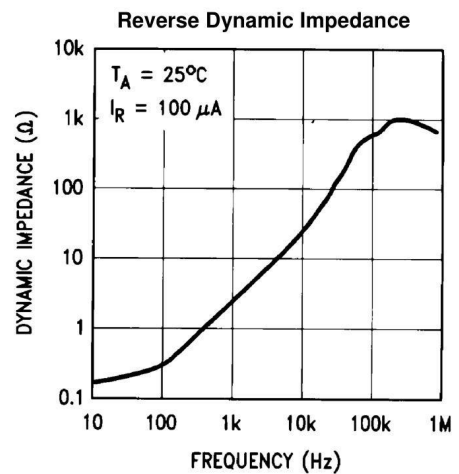

Figure 9.

TYPICAL PERFORMANCE CHARACTERISTICS(continued)

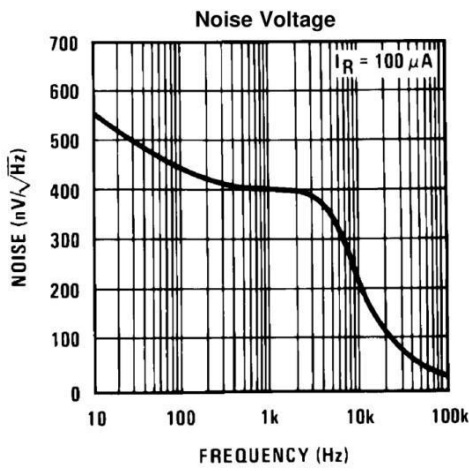

Figure 10.

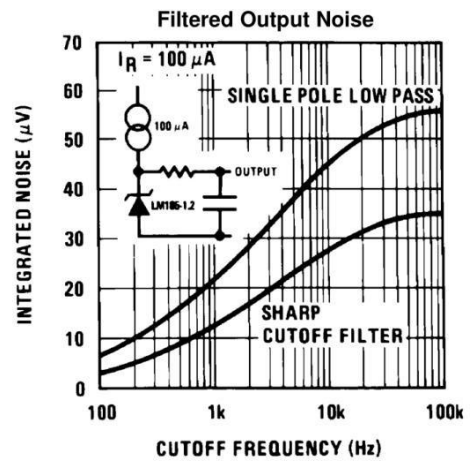

Figure 11.

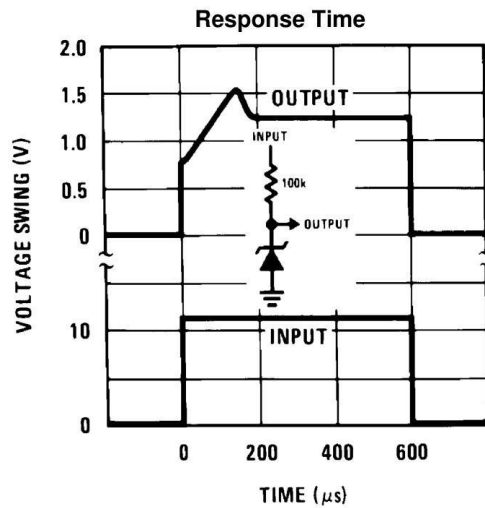

Figure 12.

7. TYPICAL PERFORMANCE CHARACTERISTICS

$V_{IN} = 2.3V \text{ TO } 30V$

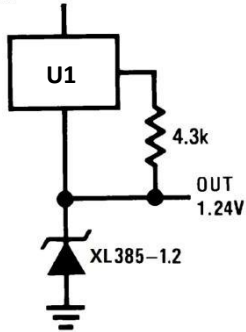

Figure 13. Wide Input Range Reference

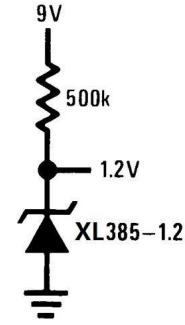

Figure 14. Micropower Reference from 9V Battery

Note 1: U1 uses a constant current source IC, such as an LM334 or equivalent.

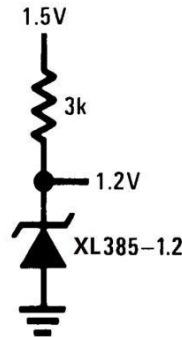
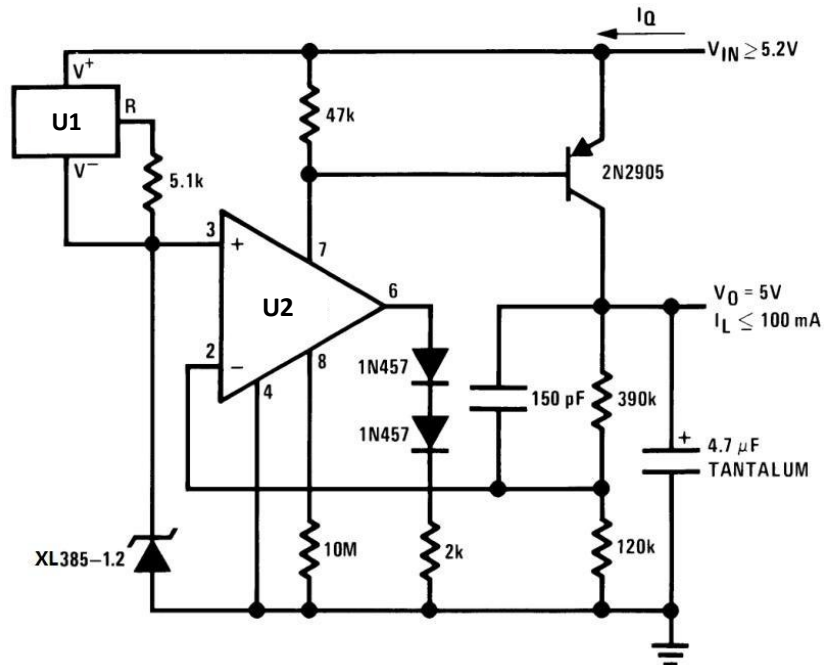

Figure 15. Reference from 1.5V Battery



* $I_Q = 30\mu A$

Note 2: U2 uses a constant current source IC, such as an LM4250C or equivalent.

Figure 16. Micropower*5V Regulator

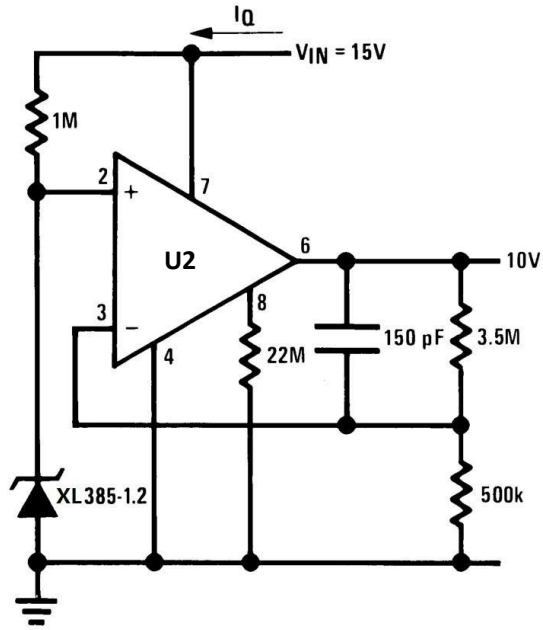

* $I_Q \approx 20\mu A$ standby current

Figure 17. Micropower* 10V Reference

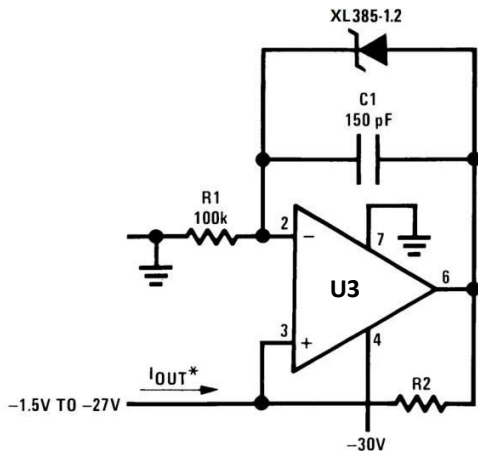

Figure 18.

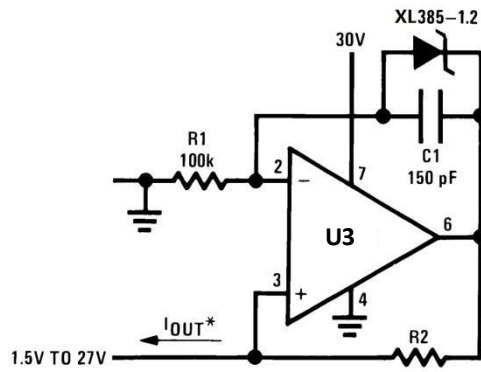

Figure 19. Precision $1\mu A$ to 1mA Current Sources

Note 3: U3 uses a constant current source IC, such as an LM312 or equivalent.

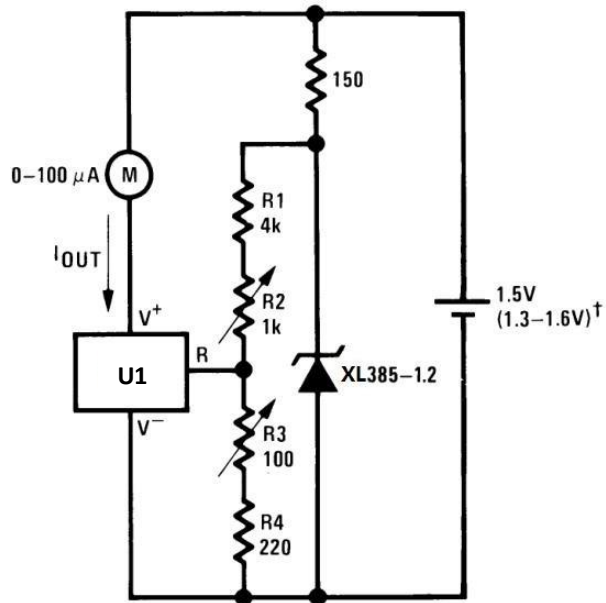

Figure 20. 20.0°C-100°C Thermometer

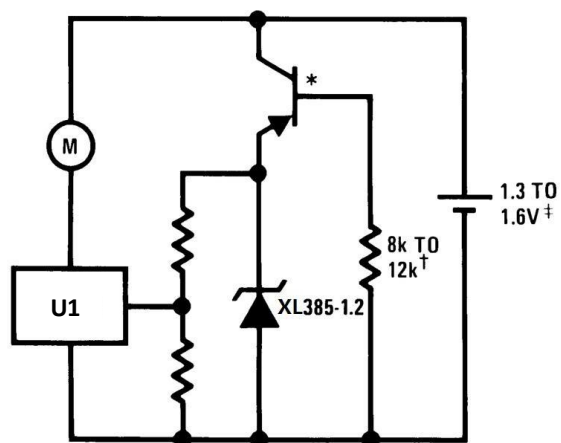

Figure 21. Lower Power Thermometer

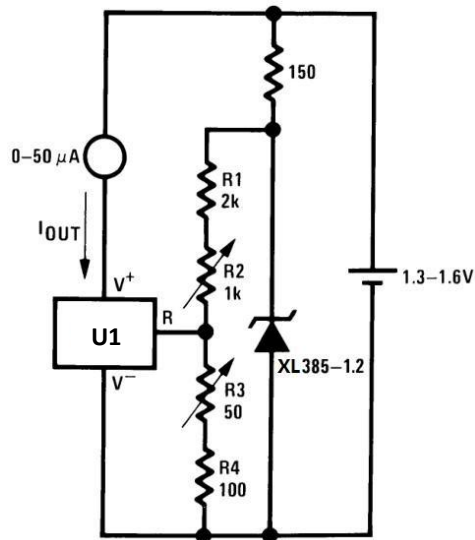

Figure 22. 0°F-50°F Thermometer

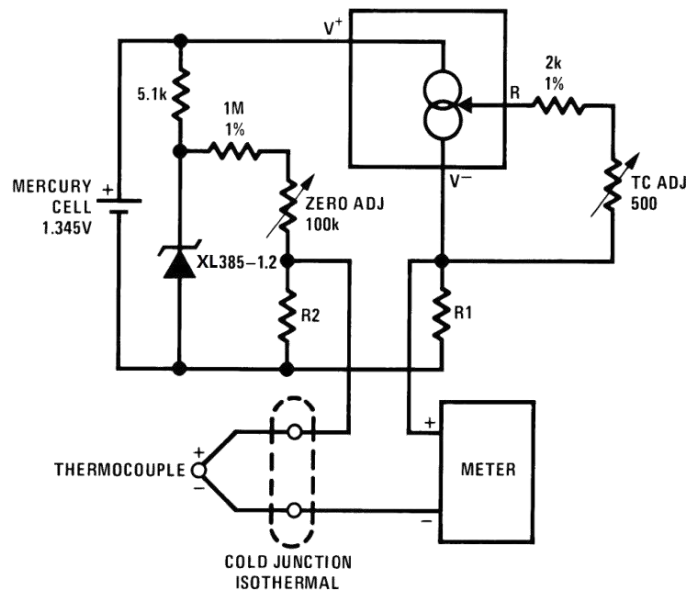

Figure 23. Micropower Thermocouple Cold Junction Compensator

Thermocouple Type	Seebeck Coefficient ($\mu\text{V}/^\circ\text{C}$)	R1 (Ω)	R2 (Ω)	Voltage Across R1 @ 25°C (mV)	Voltage Across R2 (mV)
J	52.3	523	1.24k	15.60	14.32
T	42.8	432	1k	12.77	11.78
K	40.8	412	953 Ω	12.17	11.17
S	6.4	63.4	150 Ω	1.908	1.766

Typical supply current 50 μA

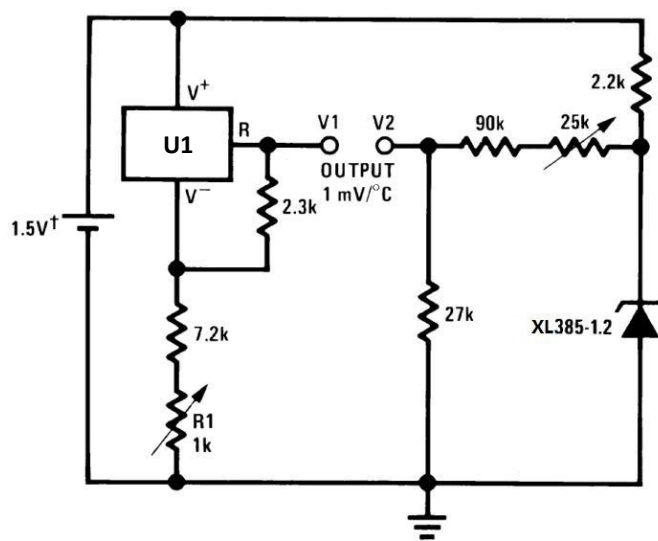
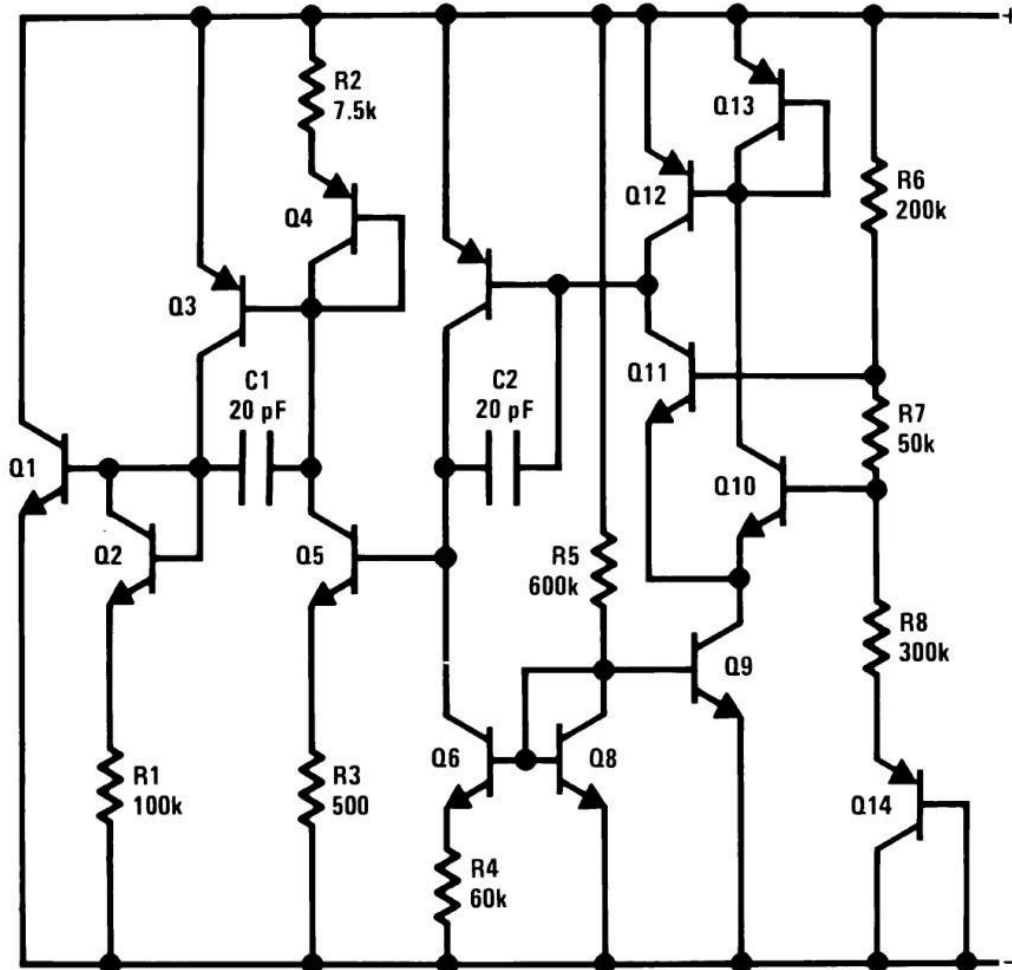

Figure 24. Centigrade Thermometer

8. SCHEMATIC DIAGRAM



9. ORDERING INFORMATION

Ordering Information

Part Number	Device Marking	Package Type	Body size (mm)	Temperature (°C)	MSL	Transport Media	Package Quantity
XL285-1.2	XL285-1.2	SOP8	4.90 * 3.90	- 40 to 85	MSL3	T&R	2500
XT285-1.2	XT285-1.2	TO-92	4.58 * 4.58	- 40 to 85	MSL3	T&R	1000
XL385-1.2	XL385-1.2	SOP8	4.90 * 3.90	- 40 to 85	MSL3	T&R	2500
XT385-1.2	XT385-1.2	TO-92	4.58 * 4.58	- 40 to 85	MSL3	T&R	1000
XB385M3-1.2	R11	SOT23-3	2.90 * 1.30	- 40 to 85	MSL3	T&R	3000

10. DIMENSIONAL DRAWINGS

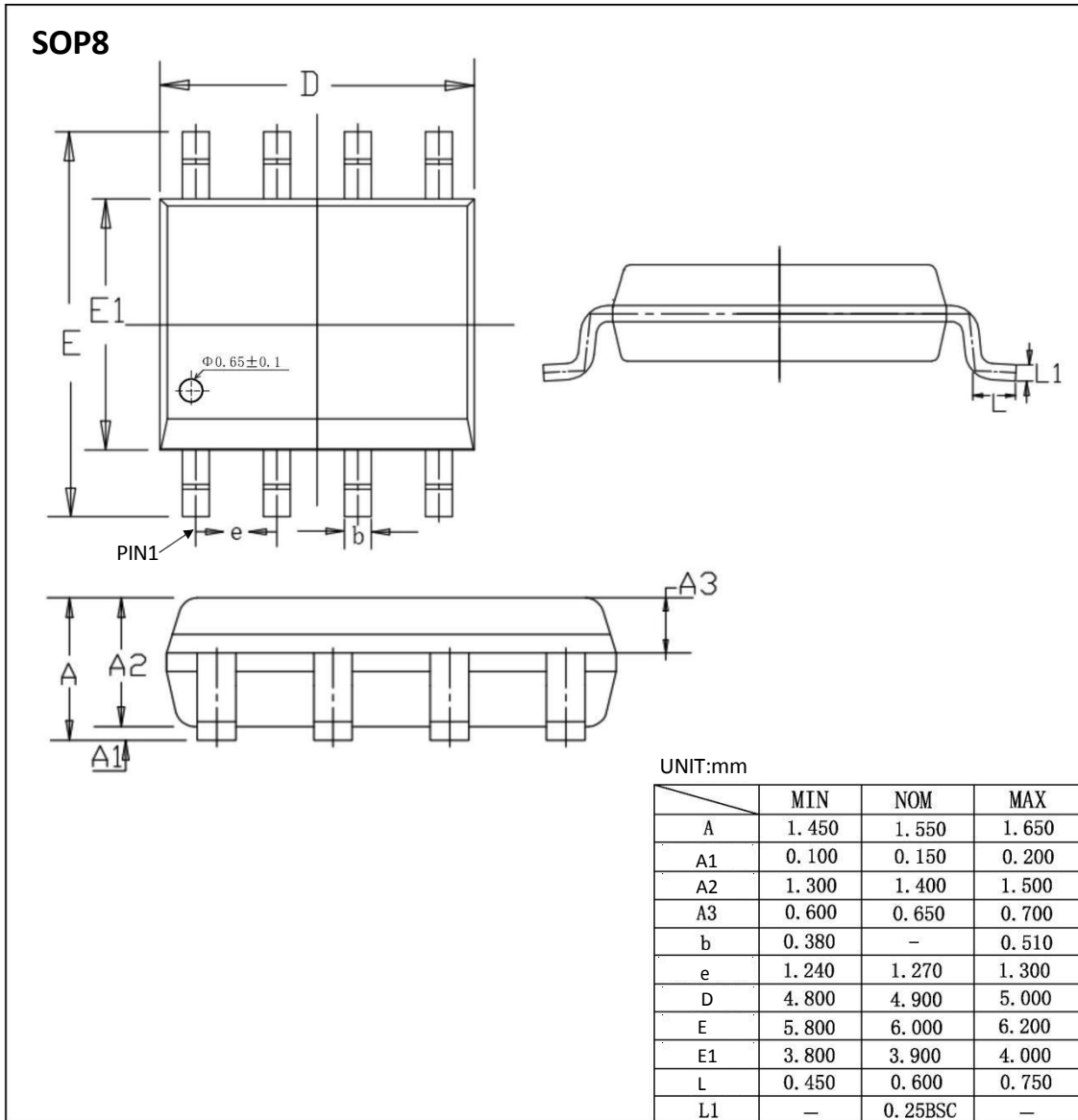

TO-92

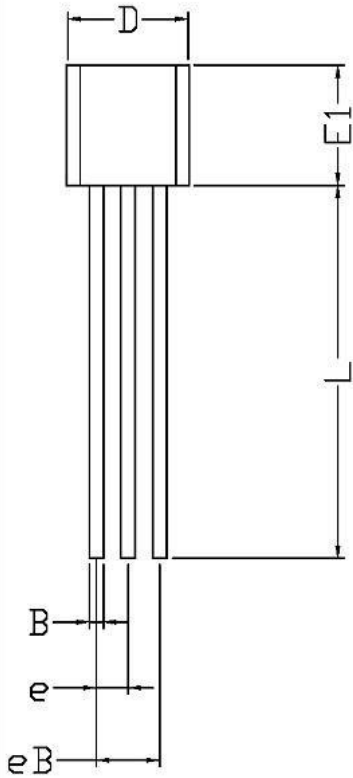

SYMBOL	MIN	MAX
A	3.46	3.96
A1	1.02 TYP	
B	0.36	0.56
C	1.80 TYP	
D	4.33	4.83
E1	4.33	4.83
E	3.35	3.85
eB	2.54 TYP	
e	1.27 TYP	
L	13.97	14.97

UNIT: mm

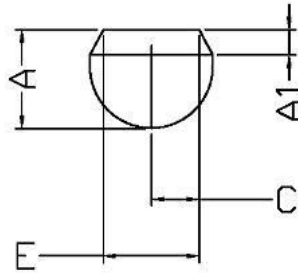

SOT-233

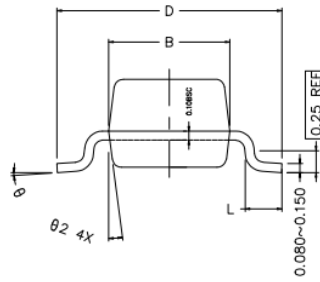
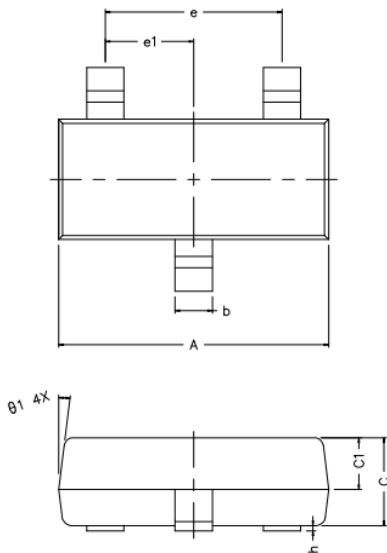

COMMON DIMENSIONS (UNITS OF MEASURE IS mm)			
	MIN	NORMAL	MAX
Δ A	2.800	2.900	3.100
B	1.200	1.300	1.400
Δ C	0.800	0.900	1.000
C1	0.500	0.550	0.600
Δ D	2.250	2.400	2.550
L	0.300	0.400	0.500
h	0.005	0.050	0.100
b	0.300	0.400	0.500
e	1.90 TYPE		
e1	0.95 TYPE		
θ_1	7° TYPE		
θ_2	7° TYPE		
θ	0° ~ 7°		

[if you need help contact us. Xinluda reserves the right to change the above information without prior notice]