



RS3A THRU RS3M

GLASS PASSIVATED FAST RECOVERY RECTIFIER

Reverse Voltage: 50 to 1000 Volts

Forward Current:3.0Ampere

SMB(DO-214AA)

FEATURES

- Glass passivated junction
- For Surface Mount Applications, Easy to pick and place
- Plastic package has Underwriters Laboratory Flammability Classification 94V-0
- High temperature soldering guaranteed:260°C/10 seconds at terminals,
- Component in accordance to RoHS 2002/95/EC and WEEE 2002/96/EC

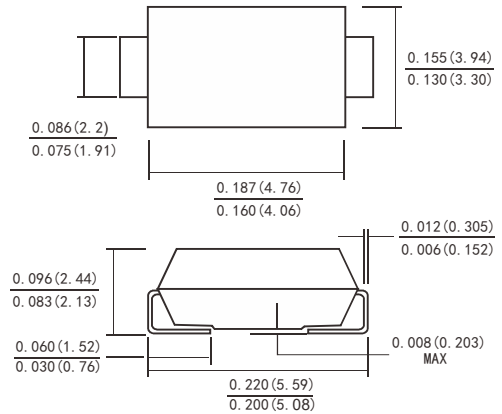

MECHANICAL DATA

- Case: JEDEC DO-214AA molded plastic over glass passivated chip
- Terminals: Solder plated
- Polarity: Color band denotes cathode end
- Weight: 0.002 ounce, 0.064 g

MAXIMUM RATINGS AND ELECTRICAL CHARACTERISTICS

(Rating at 25°C ambient temperature unless otherwise specified.Single phase ,half wave ,60Hz,resistive or inductive load. For capacitive load,derate current by 20%.)

	Symbols	RS3A	RS3B	RS3D	RS3G	RS3J	RS3K	RS3M	Units
Maximum Recurrent Peak Reverse Voltage	V_{RRM}	50	100	200	400	600	800	1000	Volts
Maximum RMS Voltage	V_{RMS}	35	70	140	280	420	560	700	Volts
Maximum DC Blocking Voltage	V_{DC}	50	100	200	400	600	800	1000	Volts
Maximum Average Forward Rectified Current at $T_L=100^\circ\text{C}$	$I_{(AV)}$	3.0							Amps
Peak Forward Surge Current 8.3ms single half sine-wave superimposed on rated load (JEDEC method)	I_{FSM}	80.0							Amps
Maximum Instantaneous Forward Voltage at 3.0 A	V_F	1.3							Volts
Maximum DC Reverse Current at rated DC blocking voltage	$T_A=25^\circ\text{C}$	5.0							μA
	$T_A=125^\circ\text{C}$	30							
	$T_A=150^\circ\text{C}$	50							
Maximum reverse recovery time(Note1)	t_{rr}	150				250	500		ns
Typical junction capacitance(Note2)	C_J	15.0							pF
Operating junction and storage temperature range	T_J T_{STG}	-55 to+175							$^\circ\text{C}$

Note: 1. Test conditions: $I_F=0.5\text{A}$, $I_R=1.0\text{A}$, $I_{RR}=0.25\text{A}$.

2. Measured at 1MHz and applied reverse voltage of 4.0 Volts D.C.

RATINGS AND CHARACTERISTIC CURVES

RS3A THRU RS3M

FIG.1-TYPICAL FORWARD CURRENT DERATING CURVE

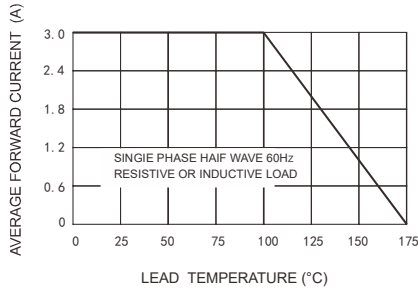

FIG.2-MAXIMUM NON-REPETITIVE FORWARD SURGE CURRENT

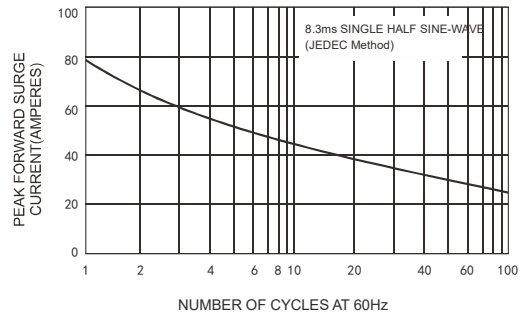

FIG.3-TYPICAL INSTANTANEOUS FORWARD CHARACTERISTICS

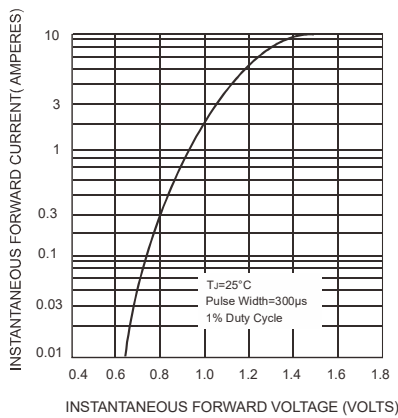

FIG.4-TYPICAL REVERSE CHARACTERISTICS

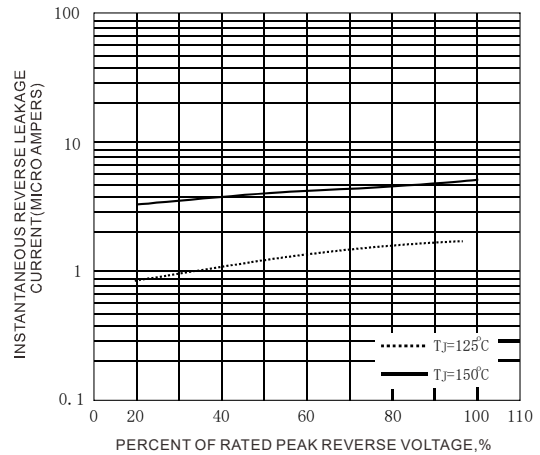

FIG.5-TYPICAL JUNCTION CAPACITANCE

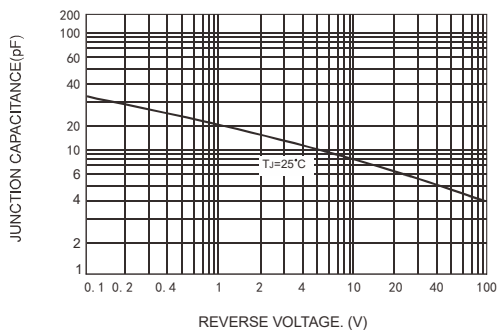

FIG.6-TEST CIRCUIT DIAGRAM AND REVERSE RECOVERY TIME CHARACTERISTIC

