

PDFN5060 Plastic-Encapsulate MOSFETS

● Features

- $V_{DS}=30V$
- $I_D=50A$
- $R_{DS(on)}@V_{GS}=10V < 8m\Omega$
- $R_{DS(on)}@V_{GS}=4.5V < 11.5m\Omega$
- Trench Power LV MOSFET technology
- Voltage controlled small signal switch
- Fast Switching Speedze

● Applications

- Battery protection
- Load switch
- Power management

● Mechanical Data

- Case: PDFN5060
Molding compound meets UL 94V-0 flammability rating, RoHS-compliant,halogen-free
- Terminals: Solder plated, solderable per MIL-STD-750,Method 2026

● Function Diagram

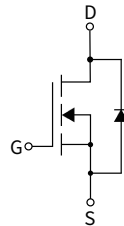
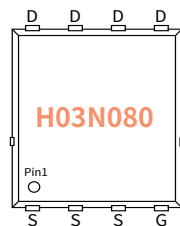

Drain-source Voltage

30 V

Drain Current

50 Ampere

PDFN5060

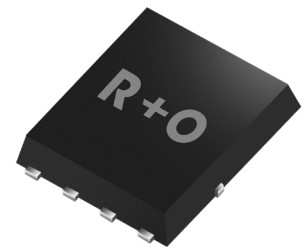

● Ordering Information

PACKAGE	PACKAGE CODE	UNIT WEIGHT(g)	REEL(pcs)	BOX(pcs)	CARTON(pcs)	DELIVERY MODE
PDFN5060	R3	0.09	5000	10000	50000	13"

● Maximum Ratings (Ta=25°C Unless otherwise specified)

PARAMETER	SYMBOL	UNIT	VALUE
Drain-source Voltage	V_{DS}	V	30
Gate-source Voltage	V_{GS}	V	± 20
Drain Current	I_D	A	50
Pulsed Drain Current ⁽¹⁾	I_{DM}	A	140
Total Power Dissipation	P_D	W	41.6
Single pulse avalanche energy ⁽²⁾	EAS	mJ	49
Junction temperature	T_J	°C	-55 ~+150
Storage temperature	T_{stg}	°C	-55 ~+150
Thermal Resistance Junction-to-Case	$R_{\theta JC}$	°C / W	3

● Static Parameter Characteristics (T_j=25°C Unless otherwise specified)

PARAMETER	SYMBOL	Condition	UNIT	Min	Typ	Max
Drain-Source Breakdown Voltage	BV _{DSS}	V _{GS} = 0V, I _D =250μA	V	30	—	—
Zero Gate Voltage Drain Current	I _{DSS}	V _{DS} =30V, V _{GS} =0V	μA	—	—	1.0
Gate-Body Leakage Current	I _{GSS}	V _{GS} = ±20V, V _{DS} =0V	nA	—	—	±100
Gate Threshold Voltage	V _{GS(th)}	V _{DS} = V _{GS} , I _D =250μA	V	1.0	1.6	2.5
Static Drain-Source On-Resistance ⁽³⁾	R _{DS(on)}	V _{GS} = 10V, I _D =12A	mΩ	—	6.1	8
		V _{GS} = 4.5V, I _D =10A		—	8.5	11.5
Forward Transconductance	g _{FS}	V _{DS} =5.0V, I _D =20A	S	—	18	—

● Dynamic Parameters

PARAMETER	SYMBOL	Condition	UNIT	Min	Typ	Max
Input Capacitance	C _{iss}	V _{DS} =15V, V _{GS} =0V, f=1MHZ	pF	—	1014	—
Output Capacitance	C _{oss}			—	163	—
Reverse Transfer Capacitance	C _{rss}			—	93	—

● Switching Parameters

PARAMETER	SYMBOL	Condition	UNIT	Min	Typ	Max
Turn-on Delay Time	t _{D(on)}	V _{GS} =10V, V _{DD} =15V, I _D =20A, R _{GEN} =2.7Ω	nS	—	10	—
Turn-on Rise Time	t _r		nS	—	10	—
Turn-off Delay Time	t _{D(off)}		nS	—	20	—
Turn-off fall Time	t _f		nS	—	15	—
Total Gate Charge	Q _g	V _{DS} =15V, I _D =25A V _{GS} =10V	nC	—	15	—
Gate-Source Charge	Q _{gs}		nC	—	3.3	—
Gate-Drain Charge	Q _{gd}		nC	—	3.5	—

● Driian-Source Diode Characteristics

PARAMETER	SYMBOL	Condition	UNIT	Min	Typ	Max
Diode Forward Voltage	V _{SD}	I _S =50A, V _{GS} =0V	V	—	—	1.3
Maximum Body-Diode Continuous Current	I _S	—	A	—	—	50
Reverse Recovery time	t _{rr}	I _{SD} =50A di/dt=100A/us	nS	—	20	—
Reverse Recovery Charge	Q _{rr}		nC	—	11	—

Note :

(1)Repetitive Rating: Pulse width limited by maximum junction temperature.

(2)EAS condition : T_j=25°C ,V_{DD}=15V,V_G=10V,L=0.5mH,I_{AS}=14A,R_G=25Ω.

(3)Pulse Test: Pulse Width ≤ 300μs, Duty Cycle ≤ 2%.

● Ratings And Characteristics Curves (Ta=25°C Unless otherwise specified)

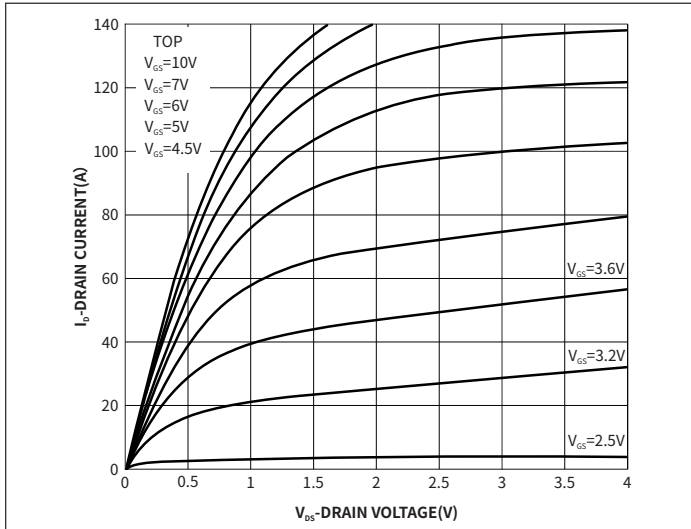

Fig.1 Output Characteristics

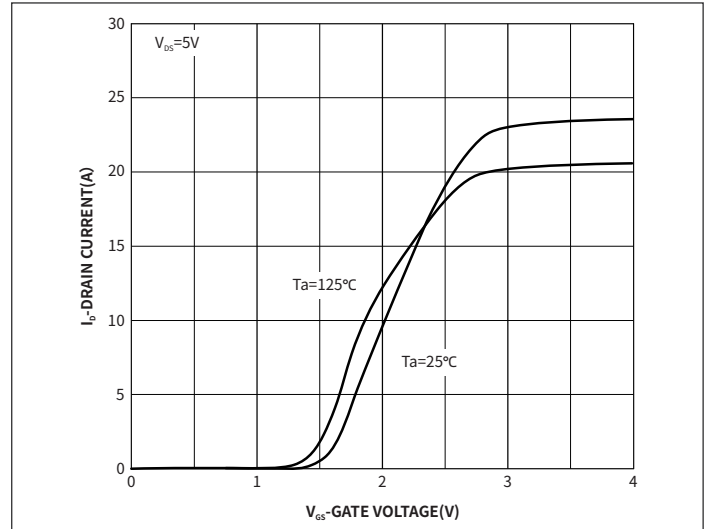

Fig.2 Transfer Characteristics

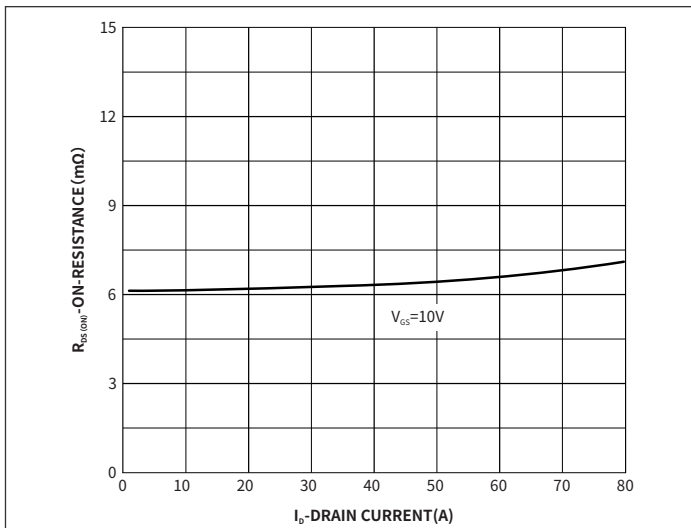

Fig.3 On-Resistance vs. Drain Current and Gate Voltage

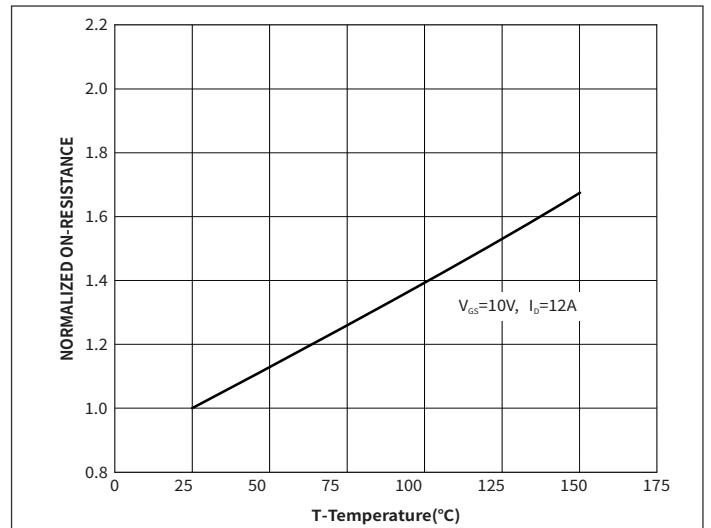

Fig.4 On-Resistance vs. Junction Temperature

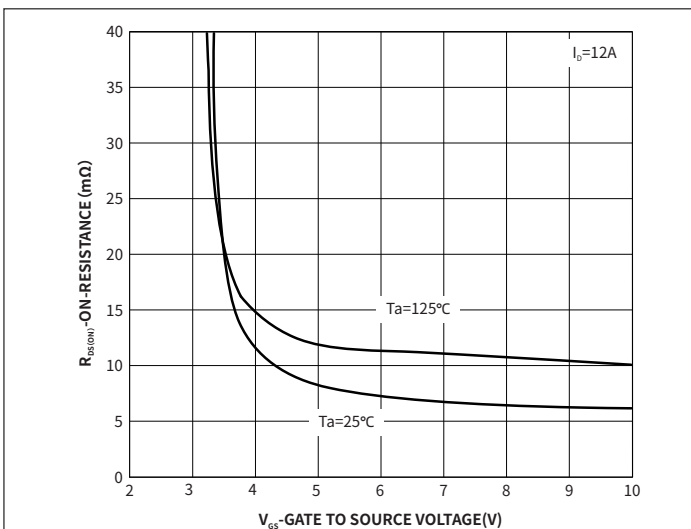

Fig.5 On-Resistance vs. Gate to Source Voltage

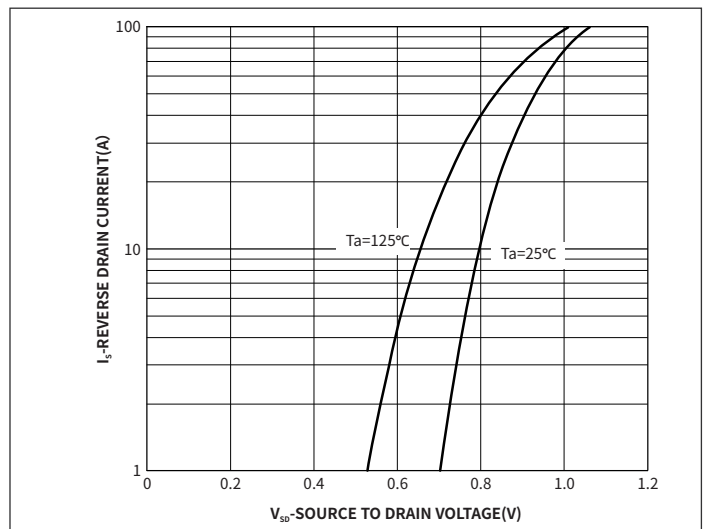
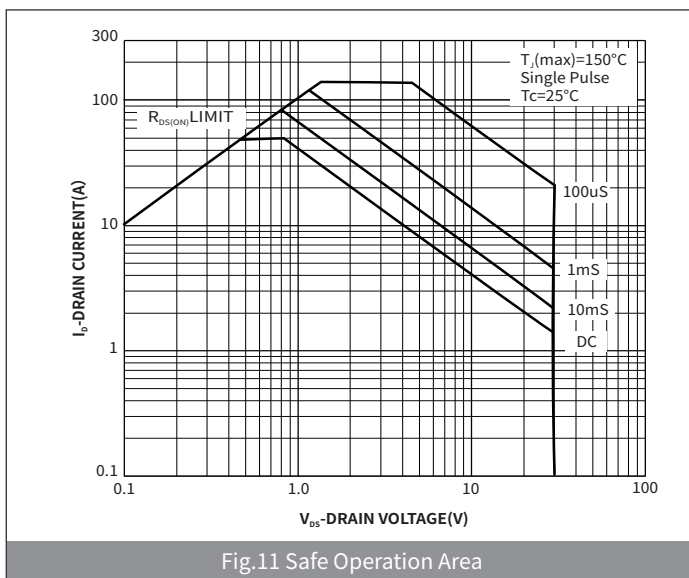
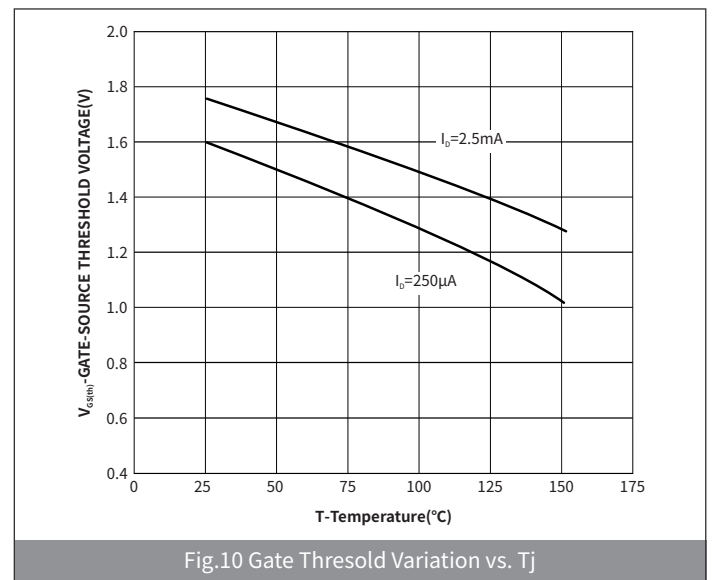
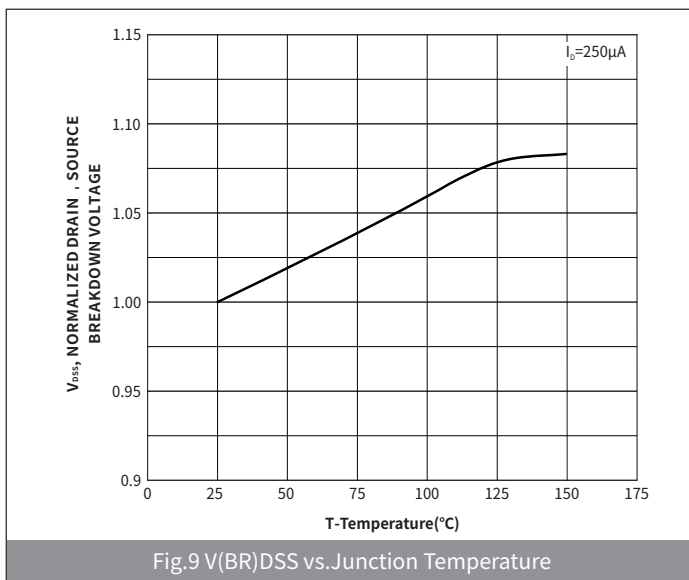
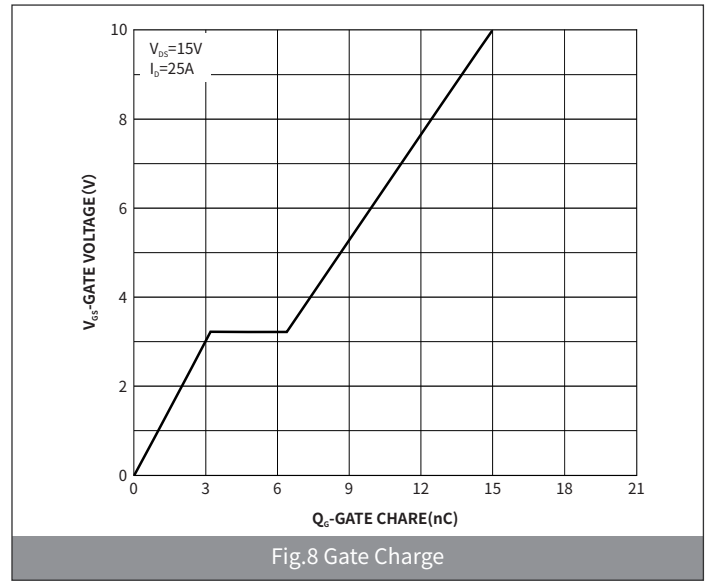
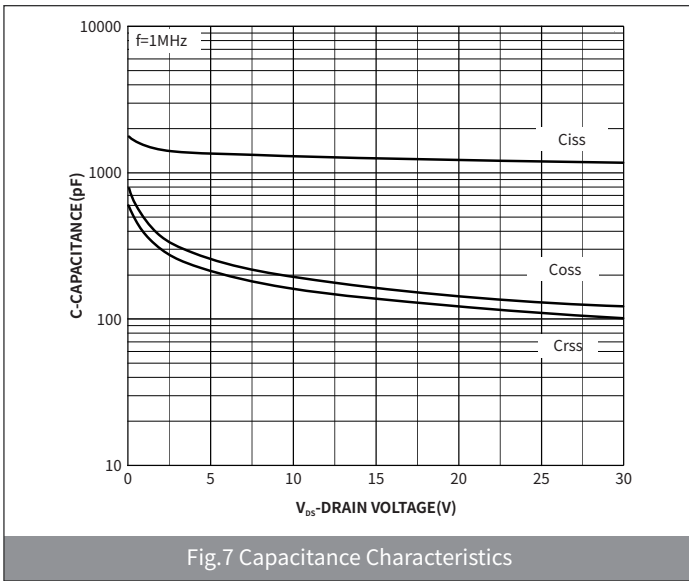

Fig.6 Typical Body-Diode Forward Characteristics

● Ratings And Characteristics Curves (Ta=25°C Unless otherwise specified)



● Ratings And Characteristics Curves (Ta=25°C Unless otherwise specified)

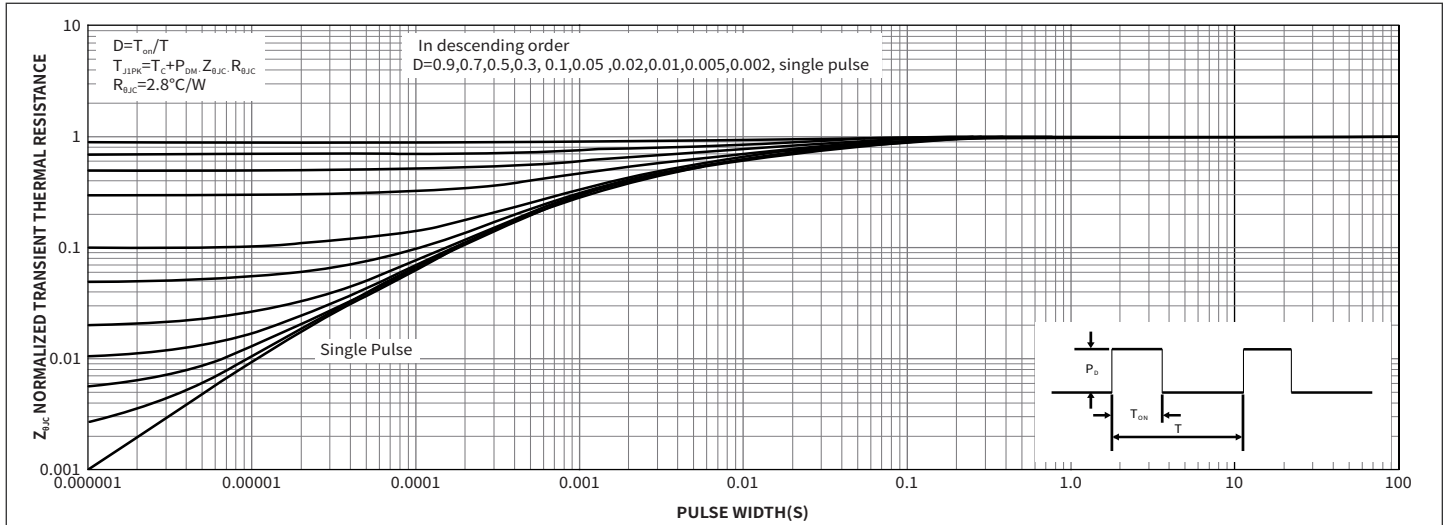
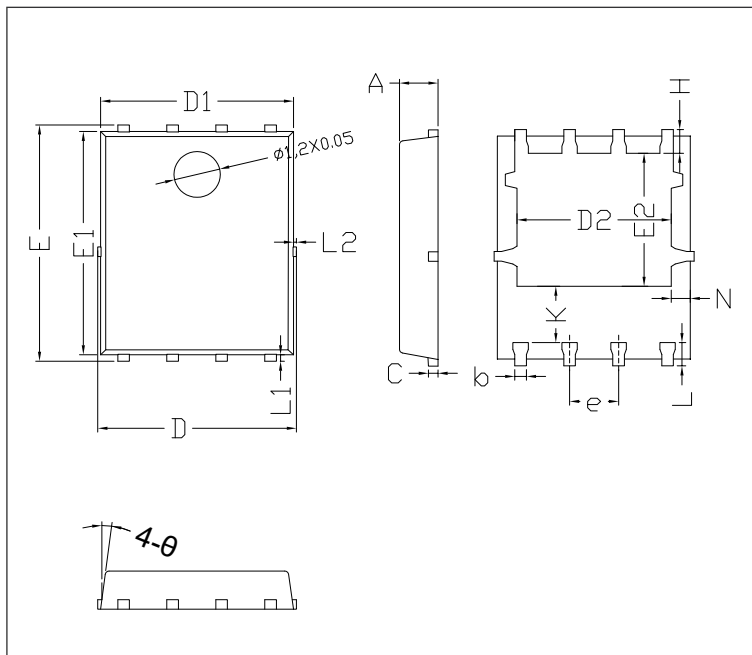

Fig.12 Normalized Maximum Transient Thermal Impedance

● Package Outline Dimensions (PDFN5060)



Symbol	Dimensions			
	Millimeters		Inches	
	Min.	Max.	Min.	Max.
A	0.90	1.12	0.035	0.044
b	0.25	0.35	0.010	0.014
C	0.11	0.34	0.004	0.0123
D	4.70	5.26	0.185	0.207
D1	4.70	5.10	0.185	0.201
D2	3.56	4.50	0.140	0.177
e	1.17	1.37	0.046	0.054
E	5.75	6.25	0.226	0.246
E1	5.60	6.00	0.220	0.236
E2	3.18	3.66	0.125	0.144
H	0.51	0.71	0.020	0.028
K	1.10	1.50	0.043	0.059
L	0.35	0.71	0.014	0.028
L1	0.06	0.20	0.002	0.008
L2	-	0.12	-	0.005
N	0.40	0.60	0.016	0.024
θ	9°	13°	9°	13°

● Suggested Pad Layout

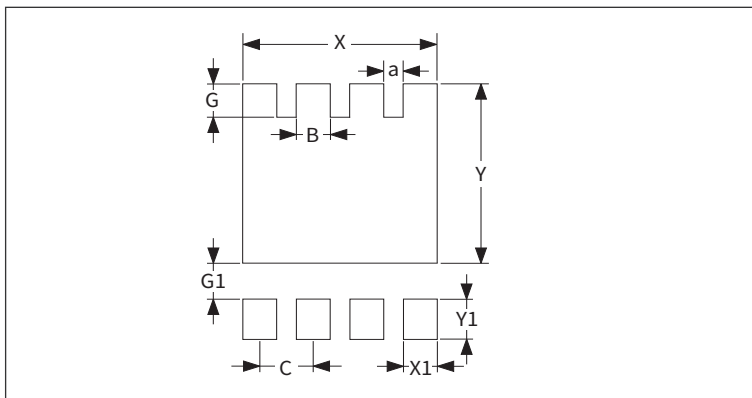

Symbol	Dimensions			
	Millimeters		Inches	
	Min.	Max.	Min.	Max.
a	0.46	0.48	0.0184	0.0192
B	0.70	0.90	0.028	0.036
C	1.17	1.37	0.0468	0.0548
G	0.75	0.95	0.03	0.038
G1	0.80	1.00	0.032	0.04
X	4.50	4.70	0.180	0.188
X1	0.70	0.90	0.028	0.036
Y	4.40	4.60	0.176	0.184
Y1	0.90	1.10	0.036	0.044

1. Gate Charge Test Circuit & Waveforms

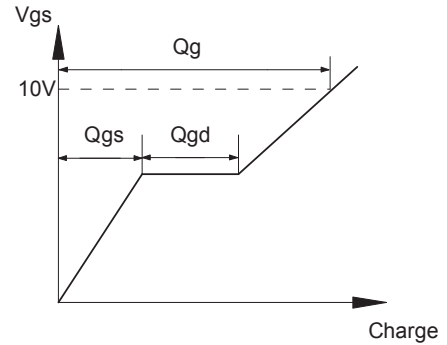
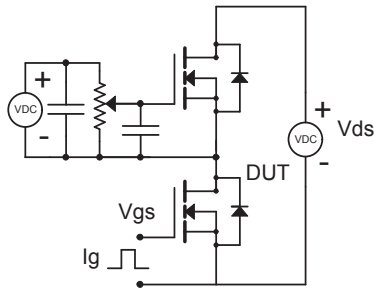

2. Resistive Switching Test Circuit & Waveforms

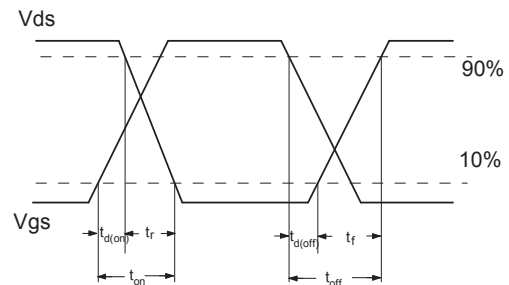
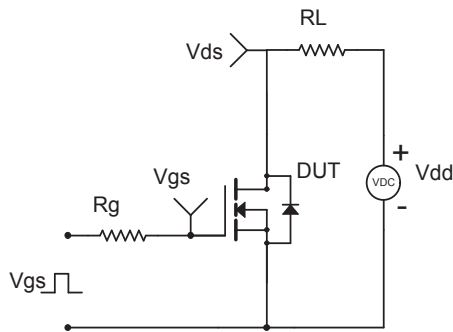

3. Unclamped Inductive Switching (UIS) Test Circuit & Waveforms

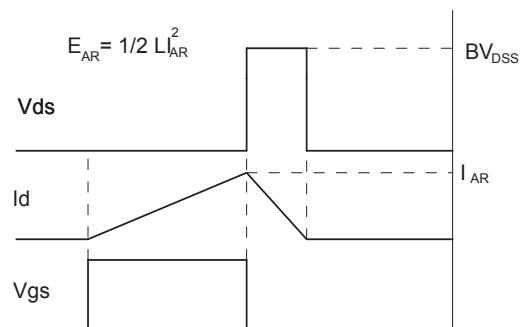
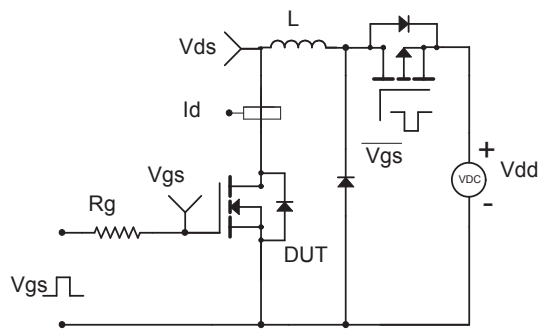

4. Diode Recovery Test Circuit & Waveforms

