

TDS:EMIC

拓電半導體

自主封測 品質把控 售後保障

WEB | WWW.TDSEMIC.COM 



電源管理



顯示驅動

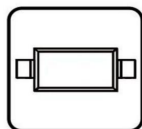

二三極管

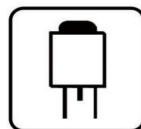

LDO穩壓器

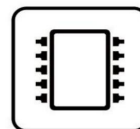

觸摸芯片

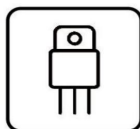

MOS管



運算放大器

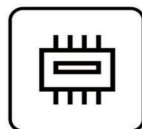

存儲芯片



MCU

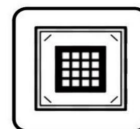

串口通信

LM337-TD

產品規格說明書

1 Features

- 1.5-A Output Current
- Line Regulation 0.01%/V (Typical)
- Load Regulation 0.3% (Typical)
- 77-dB Ripple Rejection
- 50 ppm/°C Temperature Coefficient
- Thermal Overload Protection
- Internal Short-Circuit Current Limiting Protections

2 Applications

- Industrial Power Supplies
- Factory Automation Systems
- Building Automation Systems
- PLC Systems
- Instrumentation
- IGBT Drive Negative Gate Supplies
- Networking
- Set-Top Boxes

3 Description

The LM337-TD is adjustable 3-terminal negative voltage regulators capable of supplying -1.5 A or more currents over an output voltage range of -1.2 V to -37 V. It requires only two external resistors to set the output voltage and one output capacitor for frequency compensation. The circuit design has been optimized for excellent regulation and low thermal transients. Further, the LM337-TD feature internal current limiting, thermal shutdown and safe-area compensation, making it virtually blowout-proof against overloads.

Device Information⁽¹⁾

PART NUMBER	PACKAGE	BODY SIZE (NOM)
LM337-TD	SOT-223 (4)	3.50 mm × 6.50 mm
	TO (3)	8.255 mm × 8.255 mm
	TO-220 (3)	10.16 mm × 14.986 mm

(1) For all available packages, see the orderable addendum at the end of the data sheet. The LF01 is a lead formed (bent) version of the TO-220 package.

Adjustable Negative Voltage Regulator

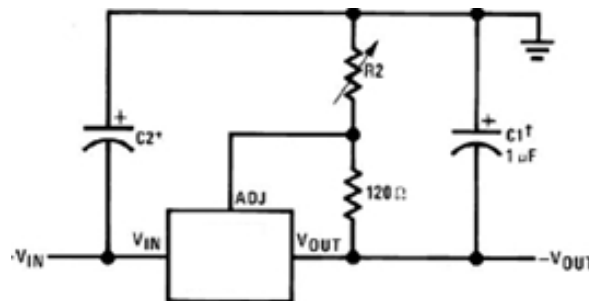

Full output current not available at high input-output voltages

$$-V_{OUT} = -1.25V \left(1 + \frac{R2}{120} \right) + (-I_{ADJ} \times R2)$$

†C1 = 1-μF solid tantalum or 10-μF aluminum electrolytic required for stability

*C2 = 1-μF solid tantalum is required only if regulator is more than 4" from power-supply filter capacitor

Output capacitors in the range of 1-μF to 1000-μF of aluminum or tantalum electrolytic are commonly used to provide improved output impedance and rejection of transients

4 Pin Configuration and Functions

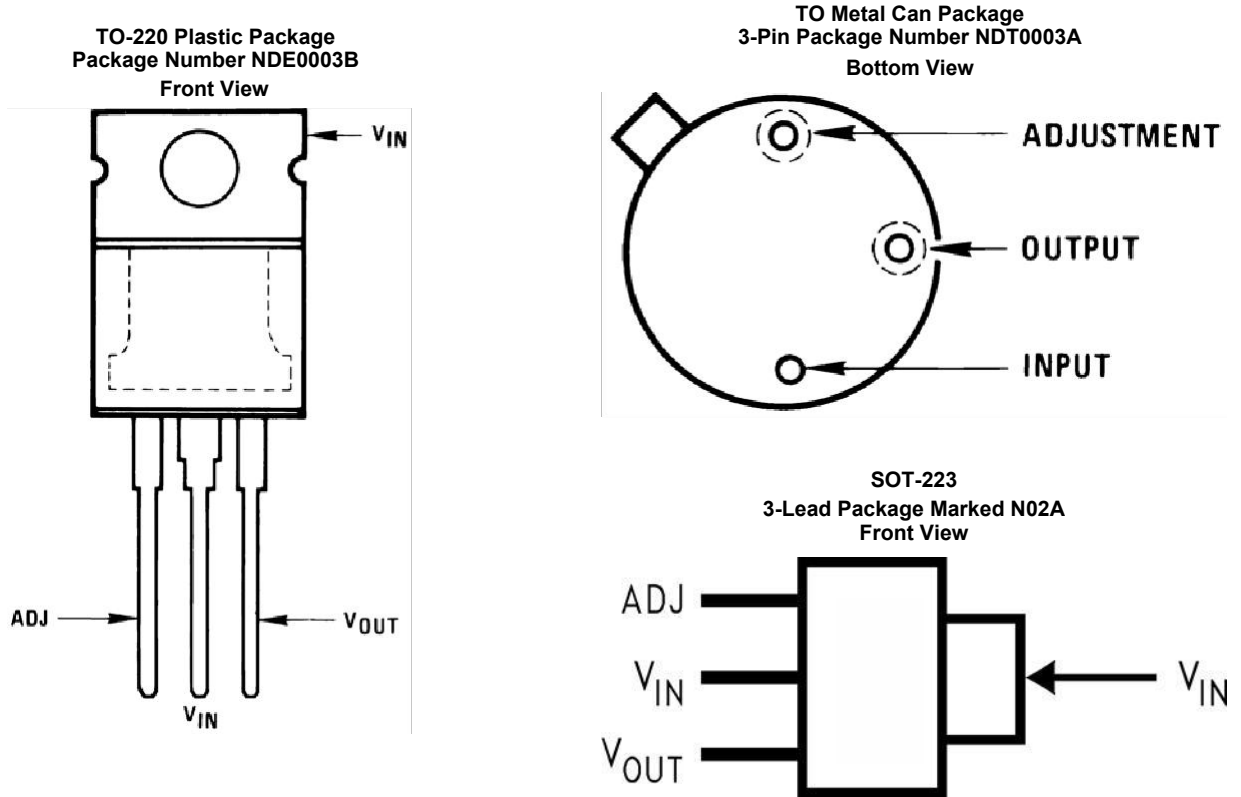

Pin Functions

NAME	PIN			I/O	DESCRIPTION
	TO-220	TO	SOT-223		
ADJ	1	1	1	—	Adjust pin
V_{IN}	2, TAB	3, CASE	2, 4	I	Input voltage pin for the regulator
V_{OUT}	3	2	3	O	Output voltage pin for the regulator

5 Specifications

5.1 Absolute Maximum Ratings

	MIN	MAX	UNIT
Power dissipation	Internally Limited		
Input-output voltage differential	-0.3	40	V
Operating junction temperature	0	125	°C
Storage temperature, T_{stg}	-65	150	°C

5.2 Recommended Operating Conditions

over operating free-air temperature range (unless otherwise noted)

	MIN	MAX	UNIT
Operating junction temperature	LM337-TD		
	0	125	°C

5.3 Electrical Characteristics

Unless otherwise specified, these specifications apply $0^{\circ}\text{C} \leq T_j \leq 125^{\circ}\text{C}$ for the LM337-TD; $V_{\text{IN}} - V_{\text{OUT}} = 5\text{ V}$; and $I_{\text{OUT}} = 0.1\text{ A}$ for the TO package and $I_{\text{OUT}} = 0.5\text{ A}$ for the SOT-223 and TO-220 packages. Although power dissipation is internally limited, these specifications are applicable for power dissipations of 2 W for the TO and SOT-223, and 20 W for the TO-220. I_{MAX} is 1.5 A for the SOT-223 and TO-220 packages, and 0.2 A for the TO package.

PARAMETER	TEST CONDITIONS	LM137			LM337-N			UNIT	
		MIN	TYP	MAX	MIN	TYP	MAX		
Line regulation	$T_J = 25^{\circ}\text{C}$, $3\text{ V} \leq V_{\text{IN}} - V_{\text{OUT}} \leq 40\text{ V}^{(1)}$ $I_L = 10\text{ mA}$		0.01	0.02		0.01	0.04	%/V	
Load regulation	$T_J = 25^{\circ}\text{C}$, $10\text{ mA} \leq I_{\text{OUT}} \leq I_{\text{MAX}}$		0.3%	0.5%		0.3%	1%		
Thermal regulation	$T_J = 25^{\circ}\text{C}$, 10-ms Pulse		0.002	0.02		0.003	0.04	%/W	
Adjustment pin current			65	100		65	100	μA	
Adjustment pin current charge	$10\text{ mA} \leq I_L \leq I_{\text{MAX}}$ $3\text{ V} \leq V_{\text{IN}} - V_{\text{OUT}} \leq 40\text{ V}$, $T_A = 25^{\circ}\text{C}$		2	5		2	5	μA	
Reference voltage	$3\text{ V} \leq V_{\text{IN}} - V_{\text{OUT}} \leq 40\text{ V}$, ⁽²⁾ $10\text{ mA} \leq I_{\text{OUT}} \leq I_{\text{MAX}}$, $P \leq P_{\text{MAX}}$	$T_J = 25^{\circ}\text{C}$ ⁽²⁾	-1.225	-1.25	-1.275	-1.213	-1.25	-1.287	V
		$-55^{\circ}\text{C} \leq T_J \leq 150^{\circ}\text{C}$	-1.2	-1.25	-1.3	-1.2	-1.25	-1.3	V
Line regulation	$3\text{ V} \leq V_{\text{IN}} - V_{\text{OUT}} \leq 40\text{ V}$, ⁽¹⁾		0.02	0.05		0.02	0.07	%/V	
Load regulation	$10\text{ mA} \leq I_{\text{OUT}} \leq I_{\text{MAX}}$, ⁽¹⁾		0.3%	1%		0.3%	1.5%		
Temperature stability	$I_{\text{MIN}} \leq I_j \leq I_{\text{MAX}}$		0.6%			0.6%			
Minimum load current	$ V_{\text{IN}} - V_{\text{OUT}} \leq 40\text{ V}$		2.5	5		2.5	10	mA	
	$ V_{\text{IN}} - V_{\text{OUT}} \leq 10\text{ V}$		1.2	3		1.5	6	mA	
Current limit	$ V_{\text{IN}} - V_{\text{OUT}} \leq 15\text{ V}$	K, DCY and NDE package	1.5	2.2	3.5	1.5	2.2	3.7	A
		NDT package	0.5	0.8	1.8	0.5	0.8	1.9	A
	$ V_{\text{IN}} - V_{\text{OUT}} = 40\text{ V}$, $T_J = 25^{\circ}\text{C}$	K, DCY and NDE package	0.24	0.4		0.15	0.4		A
		NDT package	0.15	0.17		0.1	0.17		A
RMS output noise, % of V_{OUT}	$T_j = 25^{\circ}\text{C}$, $10\text{ Hz} \leq f \leq 10\text{ kHz}$		0.003%			0.003%			
Ripple rejection ratio	$V_{\text{OUT}} = -10\text{ V}$, $f = 120\text{ Hz}$		60			60		dB	
	$C_{\text{ADJ}} = 10\text{ }\mu\text{F}$		66	77		66	77	dB	
Long-term stability	$T_J = 125^{\circ}\text{C}$, 1000 Hours		0.3%	1%		0.3%	1%		

- (1) Regulation is measured at constant junction temperature, using pulse testing with a low duty cycle. Changes in output voltage due to heating effects are covered under the specification for thermal regulation. Load regulation is measured on the output pin at a point $\frac{1}{2}$ in. below the base of the TO packages.
- (2) Selected devices with tightened tolerance reference voltage available.

5.4 Typical Characteristics

(NDE Package)

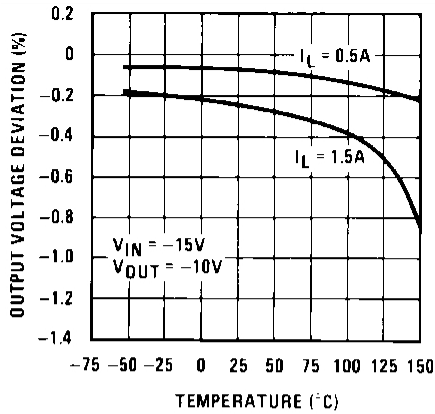

Figure 1. Load Regulation

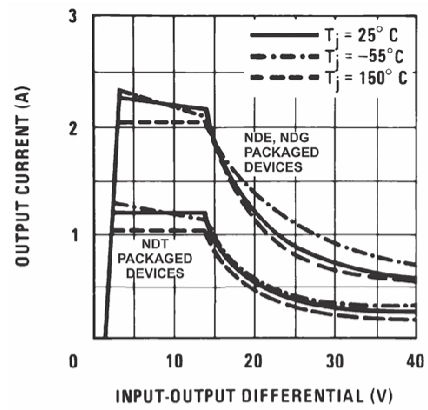

Figure 2. Current Limit

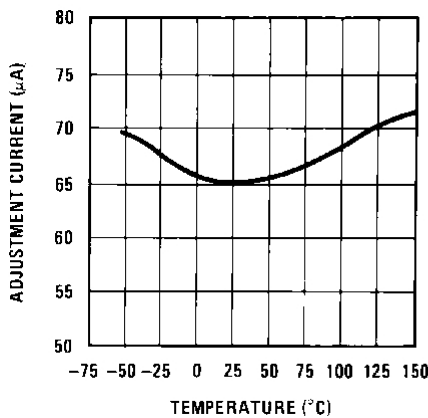

Figure 3. Adjustment Current

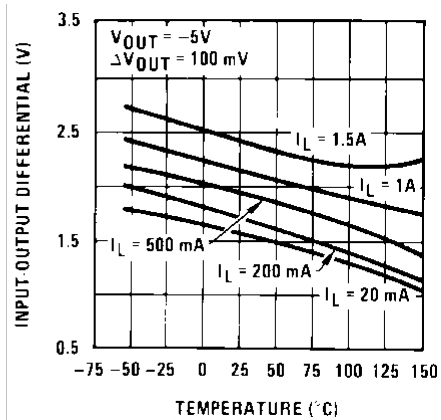

Figure 4. Dropout Voltage

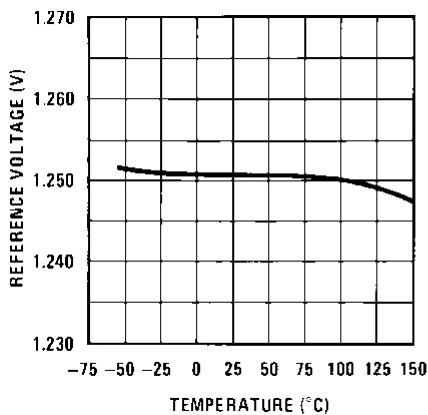

Figure 5. Temperature Stability

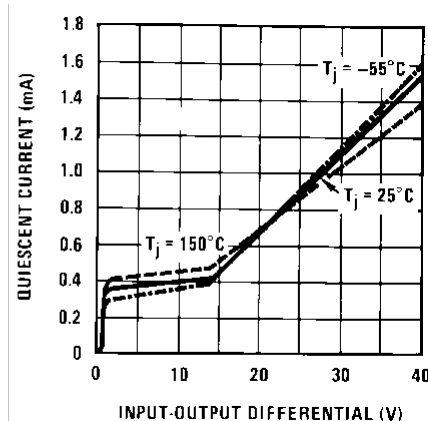

Figure 6. Minimum Operating Current

Typical Characteristics (continued)

(NDE Package)

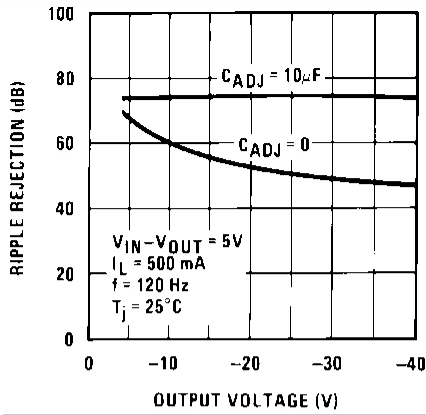

Figure 7. Ripple Rejection

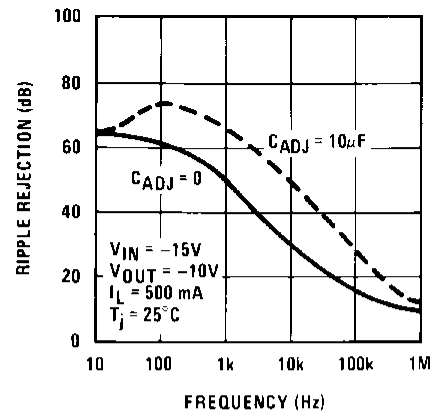

Figure 8. Ripple Rejection

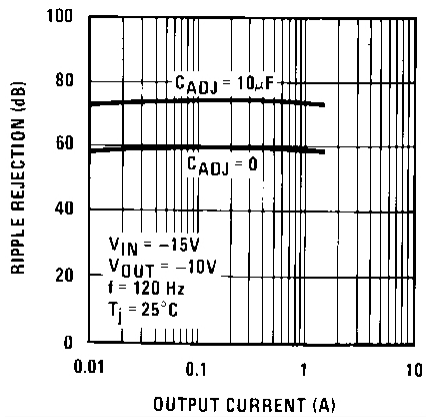

Figure 9. Ripple Rejection

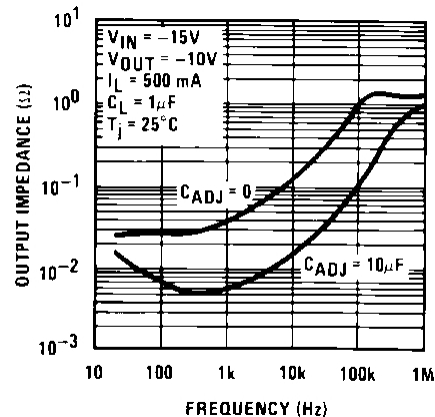

Figure 10. Output Impedance

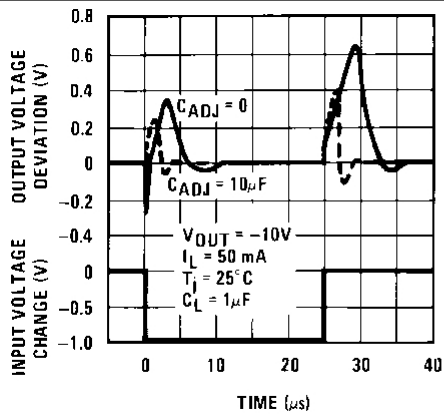

Figure 11. Line Transient Response

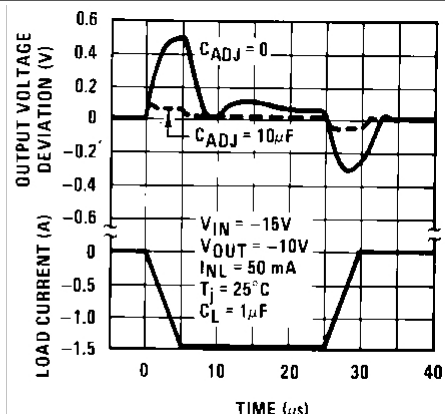
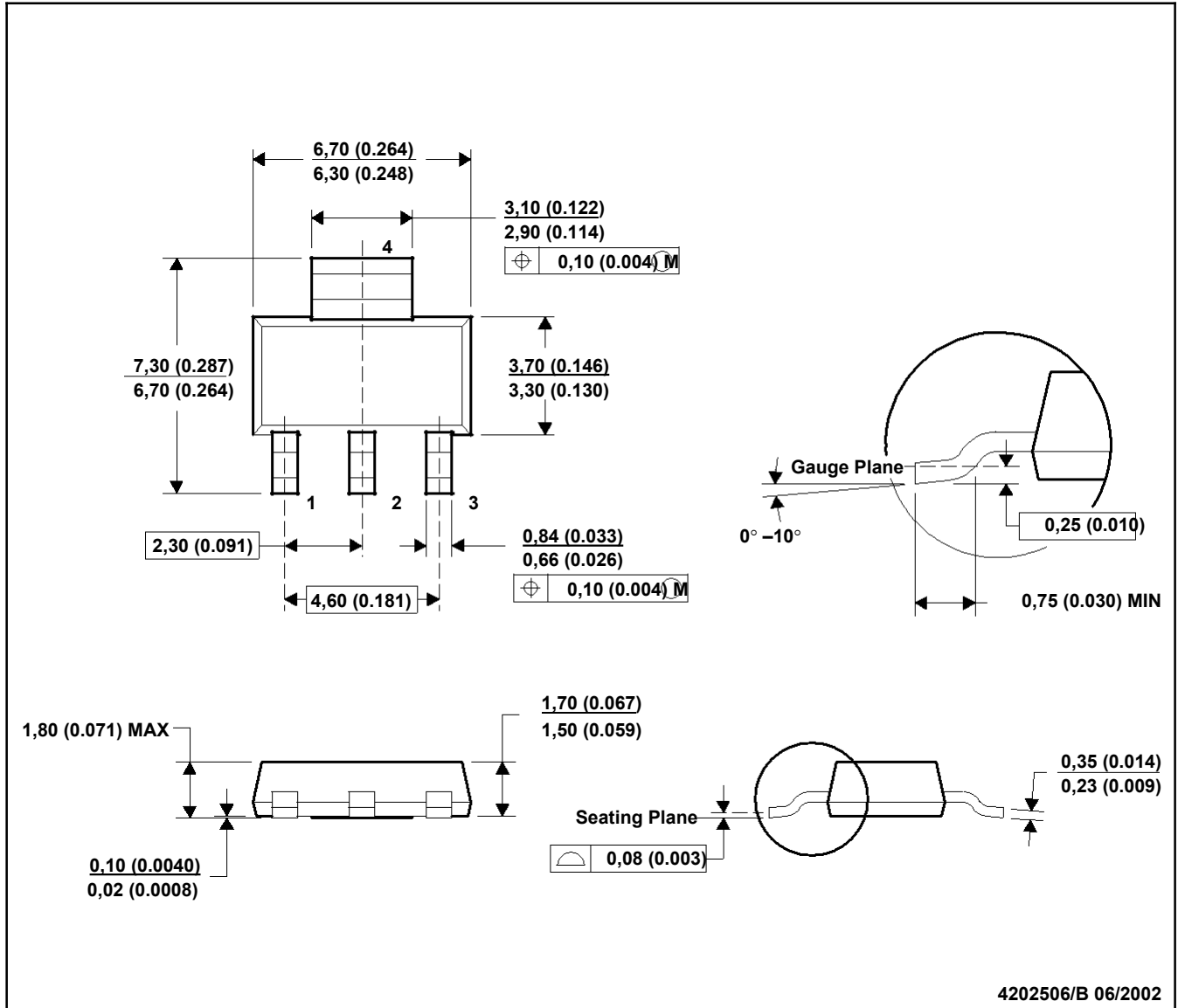

Figure 12. Load Transient Response

DCY (R-PDSO-G4)

PLASTIC SMALL-OUTLINE



- NOTES: A. All linear dimensions are in millimeters (inches).
 B. This drawing is subject to change without notice.
 C. Body dimensions do not include mold flash or protrusion.
 D. Falls within JEDEC TO-261 Variation AA.

NDG0003F

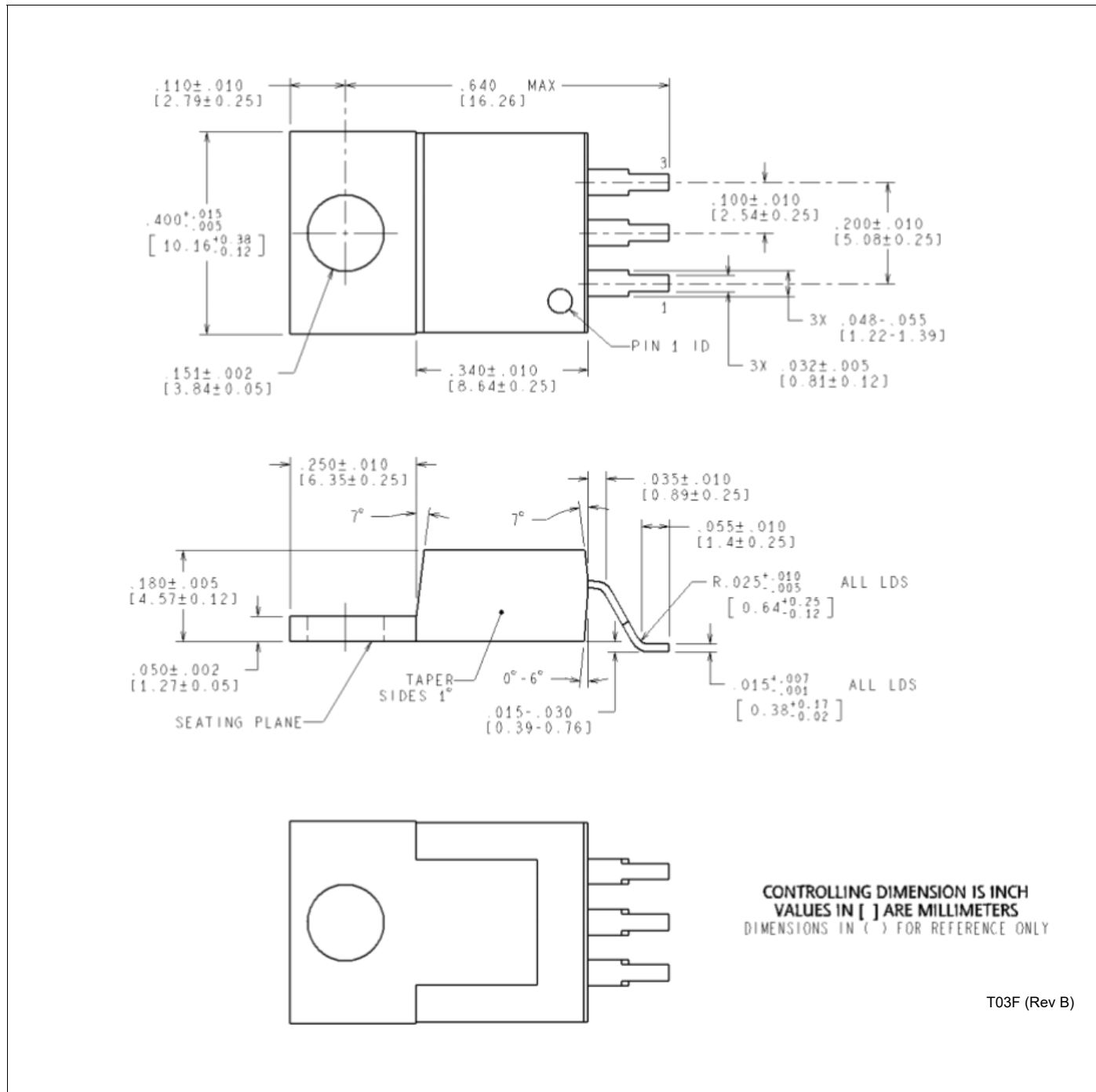

NDT0003A

