

General Purpose 1.2MHz, RRIO, 1.8V CMOS Amplifiers

Features

- General Purpose Amplifiers for Cost-Sensitive Systems
- 1.2 MHz GBW for Unity-Gain Stable
- Micro-Power: 85 μ A Supply Current Per Amplifier
- Low Input Offset Voltage: ± 3.0 mV Maximum
- Low Noise: 30 nV/ $\sqrt{\text{Hz}}$ at 1 kHz
- Single 1.8 V to 5.5 V Supply Voltage Range
- Rail-to-Rail Input and Output
- Internal RF/EMI Filter
- Extended Temperature Range: -40°C to $+125^{\circ}\text{C}$



Ordering Information

DEVICE	Package Type	MARKING	Packing	Packing Qty
LMV321AIM7/TR	SC70-5(SOT-353)	1C2,V321A	REEL	3000pcs/reel
LMV321AIM5/TR	SOT-23-5	1OIF,V321A	REEL	3000pcs/reel
LMV358AIN	DIP-8	LMV358A	TUBE	2000pcs/box
LMV358AIM/TR	SOP-8	V358A	REEL	2500pcs/reel
LMV358AIM-4K/TR	SOP-8	V358A	REEL	4000pcs/reel
LMV358AIMM/TR	MSOP-8	1MAX,V358A	REEL	3000pcs/reel
LMV358AIM8/TR	SOT-23-8	V358A	REEL	3000pcs/reel
LMV358AIMT/TR	TSSOP-8	V358A	REEL	5000pcs/reel
LMV358AIDQ2/TR	DFN-8 2*2	V358A	REEL	5000pcs/reel
LMV358AIDQ3/TR	DFN-8 3*3	V358A	REEL	5000pcs/reel
LMV324AIM/TR	SOP-14	LMV324A	REEL	2500pcs/reel
LMV324AIMS/TR	QSOP-16	V324A	REEL	2500pcs/reel
LMV324AIMT/TR	TSSOP-14	V324A	REEL	2500pcs/reel
LMV324AIN	DIP-14	LMV324A	TUBE	1000pcs/box
LMV324AILQ/TR	QFN-16 3*3	V324A	REEL	5000pcs/reel

General Description

The LMV321AI /LMV358AI /LMV324AI family of single-, dual-, and quad- channel operational amplifiers is specifically designed for general-purpose cost-sensitive systems and applications. Featuring rail-to-rail input and output (RRIO) swings, and low quiescent current (typical 85 μ A) combined with a wide bandwidth (1.2 MHz) and low noise (30 nV/ $\sqrt{\text{Hz}}$ at 1 kHz) makes this family very attractive for a variety of battery-powered applications that require a good balance between cost and performance, such as audio outputs, consumer electronics, smoke detectors, portable medical devices and white goods. The low input bias current supports these amplifiers to be used in applications with mega-ohm source impedances.

The robust design of the LMV321AI /LMV358AI /LMV324AI family provides ease-of-use to the circuit designer: unity-gain stability with capacitive loads of up to 500 pF, integrated RF/EMI rejection filter, no phase reversal in overdrive conditions, and high electro-static discharge (ESD) protection (5kV HBM). The LMV321AI /LMV358AI /LMV324AI amplifiers are optimized for operation at voltages as low as +1.8 V (± 0.9 V) and up to +5.5 V (± 2.75 V), and over the extended temperature range of -40 $^{\circ}\text{C}$ to $+125$ $^{\circ}\text{C}$.

The LMV321AI (single) is available in both SOT23-5 and SC70-5 packages. The LMV358AI (dual) is offered in SOP-8, DIP-8, TSSOP-8, DFN-8, SOT23-8 and MSOP-8 packages. The quad-channel LMV324AI is offered in DIP-14, SOP-14, TSSOP-14 QSOP-16 and QFN-16 packages.

Applications

- Battery-Powered Instruments:
 - Consumer, Industrial, Medical, Notebooks
- Audio Outputs
- Wireless Sensors:
 - Home Security, Remote Sensing, Wireless Metering
- Sensor Signal Conditioning:
 - Sensor Interfaces, Loop-Powered, Active Filters

Pin Configurations (Top View)

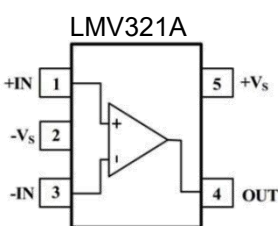

SOT-23-5/SC70-5

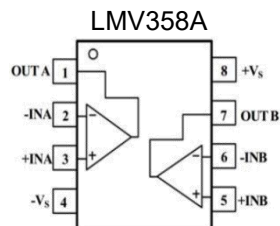

SOT-23-8

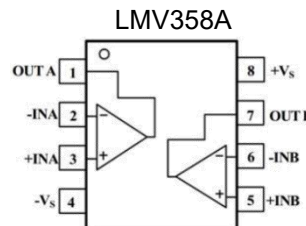

SOP-8/MSOP-8/DIP-8/TSSOP-8

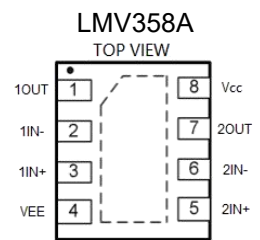

DFN-8 2*2/DFN-8 3*3

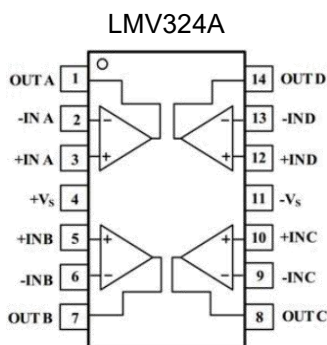

DIP-14/SOP-14/TSSOP-14

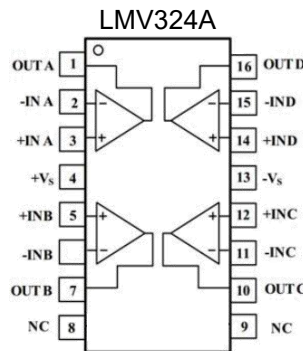

QSOP-16

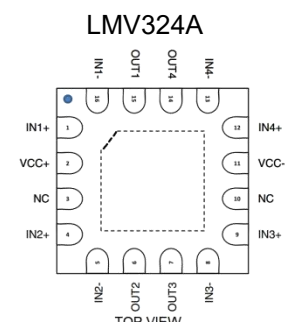

QFN-16 3*3

Limiting Value

In accordance with the Absolute Maximum Rating System (IEC 60134).

Parameter	Absolute Maximum Rating
Supply Voltage, V_{S+} to V_{S-}	10.0 V
Signal Input Terminals: Voltage, Current	$V_{S-} - 0.5$ V to $V_{S+} + 0.5$ V, ± 10 mA
Output Short-Circuit	Continuous
Storage Temperature Range, T_{stg}	-65 °C to $+150$ °C
Junction Temperature, T_J	150 °C
Lead Temperature Range (Soldering 10 sec)	260 °C

Note: Stress greater than those listed under Absolute Maximum Ratings may cause permanent damage to the device. This is a stress rating only and functional operation of the device at these or any other conditions outside those indicated in the operational sections of this specification are not implied. Exposure to absolute maximum rating conditions for extended periods may affect reliability.

ESD Rating

Parameter	Item	Value	Unit
Electrostatic Discharge Voltage	Human body model (HBM), per MIL-STD-883J / Method 3015.9 ⁽¹⁾	± 5000	V
	Charged device model (CDM), per ESDA/JEDEC JS-002-2014 ⁽²⁾	± 2000	
	Machine model (MM), per JESD22-A115C	± 250	

(1) JEDEC document JEP155 states that 500-V HBM allows safe manufacturing with a standard ESD control process. Manufacturing with less than 500-V HBM is possible if necessary precautions are taken.

(2) JEDEC document JEP157 states that 250-V CDM allows safe manufacturing with a standard ESD control process. Manufacturing with less than 250-V CDM is possible if necessary precautions are taken.

Electrical Characteristics

$V_S = 5.0V$, $T_A = +25^\circ C$, $V_{CM} = V_S / 2$, $V_O = V_S / 2$, and $R_L = 10k\Omega$ connected to $V_S / 2$, unless otherwise noted.

Boldface limits apply over the specified temperature range, $T_A = -40$ to $+125^\circ C$.

Symbol	Parameter	Conditions	Min.	Typ.	Max.	Unit
OFFSET VOLTAGE						
V_{OS}	Input offset voltage			± 0.7	± 3.0	mV
$V_{OS\ TC}$	Offset voltage drift	$T_A = -40$ to $+125^\circ C$		± 1	3.5	$\mu V/^\circ C$
PSRR	Power supply rejection ratio	$V_S = 2.0$ to 5.5 V, $V_{CM} < V_{S+} - 2V$	80	110		dB
		$T_A = -40$ to $+125^\circ C$	75			
INPUT BIAS CURRENT						
I_B	Input bias current			5	50	pA
		$T_A = -40$ to $+85^\circ C$			200	
		$T_A = -40$ to $+125^\circ C$			2000	
I_{OS}	Input offset current			10	50	pA
NOISE						
V_n	Input voltage noise	$f = 0.1$ to 10 Hz		6		μV_{P-P}
e_n	Input voltage noise density	$f = 10$ kHz		27		nV/\sqrt{Hz}
		$f = 1$ kHz		30		
I_n	Input current Noise density	$f = 1$ kHz		5		fA/\sqrt{Hz}
INPUT VOLTAGE						
V_{CM}	Common-mode voltage range		$V_{S-} - 0.1$		$V_{S+} + 0.1$	V
CMRR	Common-mode rejection ratio	$V_S = 5.5$ V, $V_{CM} = -0.1$ to 5.6 V	70	83		dB
		$V_{CM} = 0$ to 5.3 V, $T_A = -40$ to $+125^\circ C$	65			
		$V_S = 2.0$ V, $V_{CM} = -0.1$ to 2.1 V	65	77		
		$V_{CM} = 0$ to 1.8 V, $T_A = -40$ to $+125^\circ C$	60			
INPUT IMPEDANCE						
C_{IN}	Input capacitance	Differential		2.0		pF
		Common mode		3.5		
OPEN-LOOP GAIN						
A_{VOL}	Open-loop voltage gain	$R_L = 50$ k Ω , $V_O = 0.05$ to 3.5 V	90	105		dB
		$T_A = -40$ to $+125^\circ C$	85			
		$R_L = 2$ k Ω , $V_O = 0.15$ to 3.5 V	85	100		
		$T_A = -40$ to $+125^\circ C$	80			

Electrical Characteristics (continued)

$V_S = 5.0V$, $T_A = +25^\circ C$, $V_{CM} = V_S / 2$, $V_O = V_S / 2$, and $R_L = 10k\Omega$ connected to $V_S / 2$, unless otherwise noted.

Boldface limits apply over the specified temperature range, $T_A = -40$ to $+125^\circ C$.

Symbol	Parameter	Conditions	Min.	Typ.	Max.	Unit
FREQUENCY RESPONSE						
GBW	Gain bandwidth product			1.2		MHz
SR	Slew rate	$G = +1$, $C_L = 100$ pF, $V_O = 1.5$ to $3.5V$		1		V/ μ s
THD+N	Total harmonic distortion + noise	$G = +1$, $f = 1$ kHz, $V_O = 1$ VRMS		0.003		%
t_s	Settling time	To 0.1%, $G = +1$, 1V step		1.5		μ s
		To 0.01%, $G = +1$, 1V step		1.8		
t_{OR}	Overload Recovery time	To 0.1%, $V_{IN} * Gain > V_S$		2.5		μ s
OUTPUT						
V_{OH}	High output voltage swing	$R_L = 50$ k Ω	$V_{S+}-6$	$V_{S+}-3$		mV
		$R_L = 2$ k Ω	$V_{S+}-100$	$V_{S+}-65$		
V_{OL}	Low output Voltage swing	$R_L = 50$ k Ω		$V_{S-}+2$	$V_{S-}+4$	mV
		$R_L = 2$ k Ω		$V_{S-}+42$	$V_{S-}+65$	
I_{SC}	Short-circuit current	Source current through 10 Ω		40		mA
		Sink current through 10 Ω		50		
POWER SUPPLY						
V_S	Operating supply voltage		1.8		5.5	V
I_Q	Quiescent current (per amplifier)	$T_A = -40$ to $+125^\circ C$		85	125	μ A
					150	
THERMAL CHARACTERISTICS						
T_A	Operating temperature range ⁽¹⁾		-40		+125	$^\circ C$
θ_{JA}	Package Thermal Resistance	SC70-5L		333		$^\circ C/W$
		SOT23-5L		190		
		DFN2x2-8L		94		
		MSOP-8L		201		
		SOIC-8L		125		
		QFN3x3-16L		65		
		TSSOP-14L		112		
		SOIC-14L		115		

(1) Operating temperature range: $-40^\circ C$ to $+125^\circ C$. This product is designed for industrial grade applications. For automotive grade versions compliant with AEC-Q100, please conduct internal screening per the standard or contact our sales team for availability.

Typical Performance Characteristics

At $T_A = +25^\circ\text{C}$, $V_{CM} = V_S / 2$, and $R_L = 10\text{k}\Omega$ connected to $V_S / 2$, unless otherwise noted.

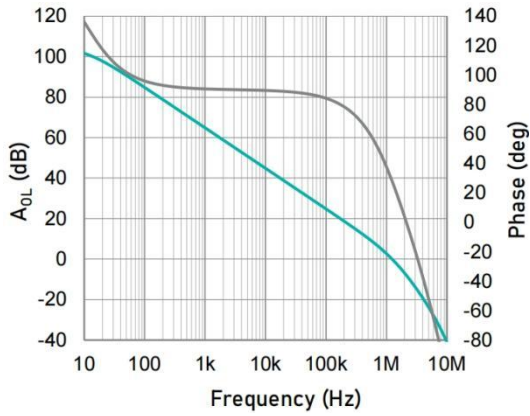

Open-loop Gain and Phase as a function of Frequency.

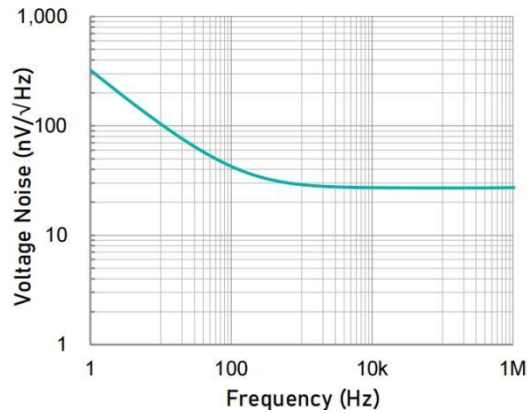

Input Voltage Noise Spectral Density as a function of Frequency.

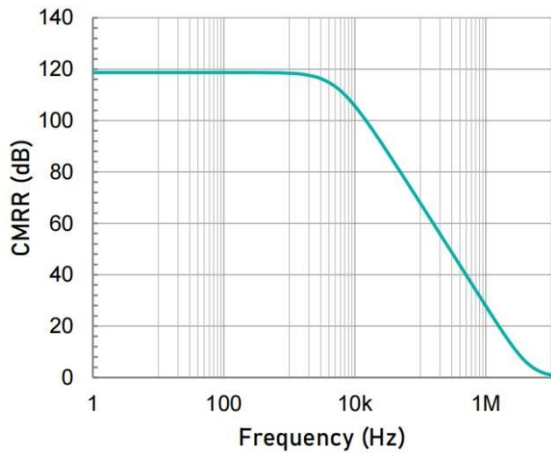

Common-mode Rejection Ratio as a function of Frequency.

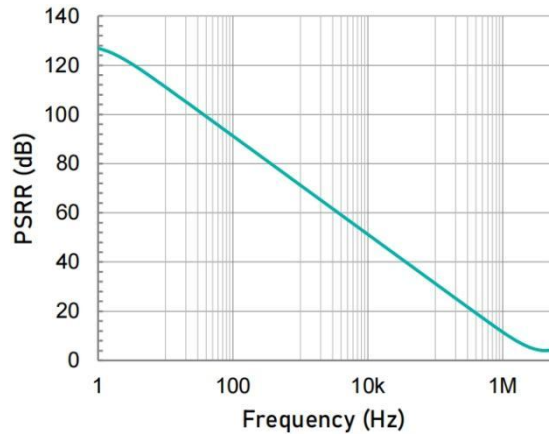

Power Supply Rejection Ratio as a function of Frequency.

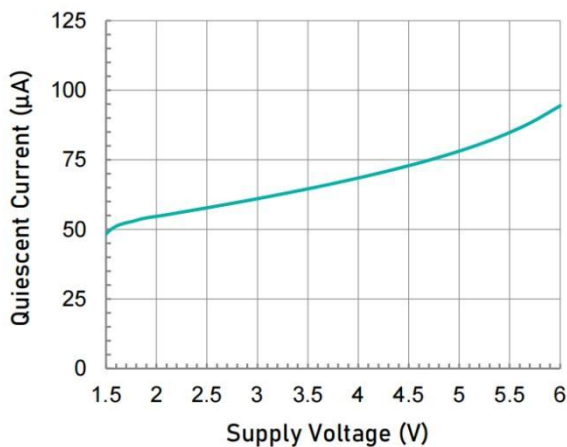

Quiescent Current as a function of Supply Voltage.

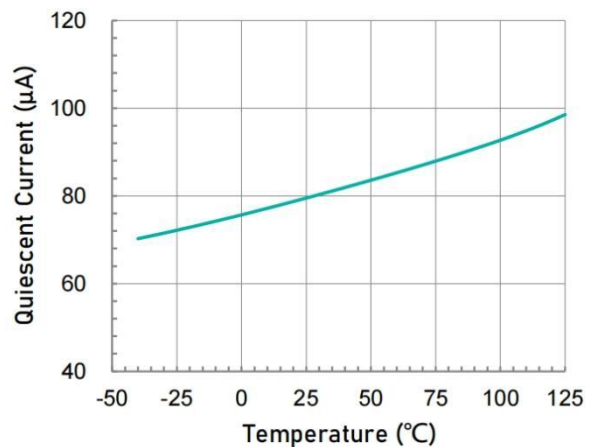

Quiescent Current as a function of Temperature.

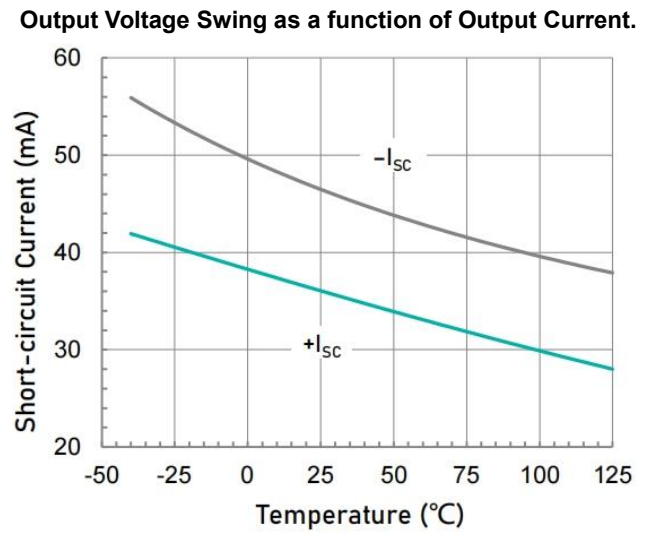
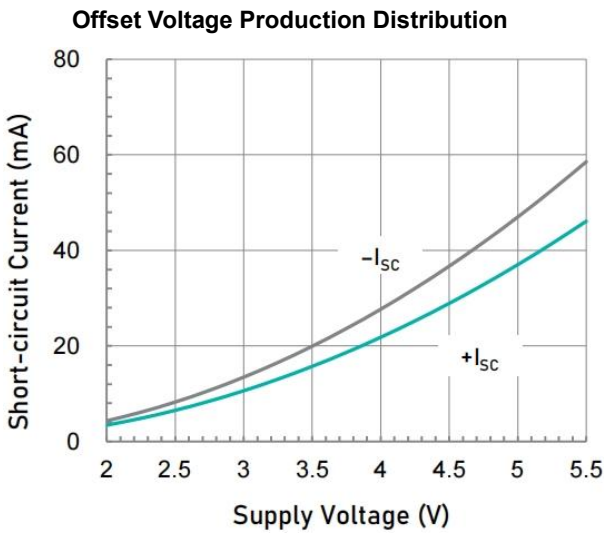
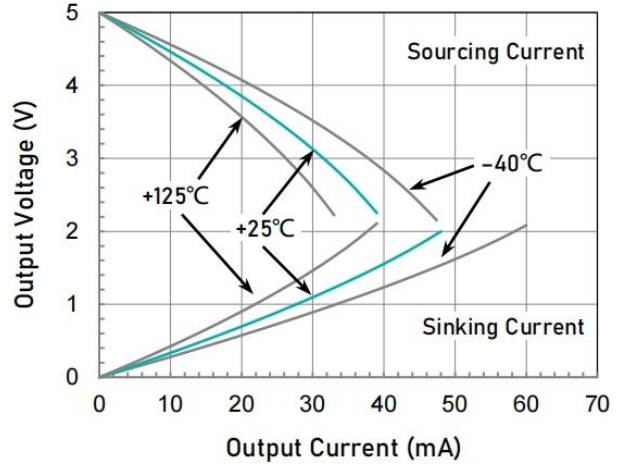
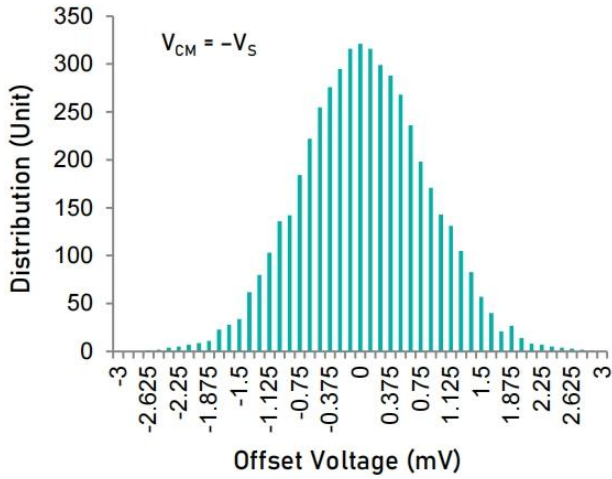

Short-circuit Current as a function of Supply Voltage.

Short-circuit Current as a function of Temperature.

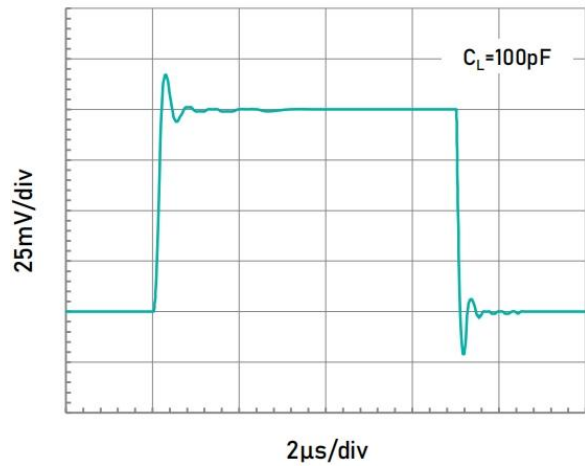
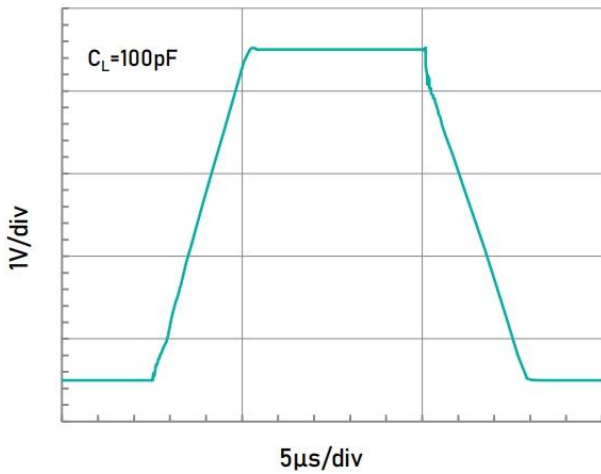

Application Notes

The LMV321AI/LMV358AI/LMV324AI is a family of low-power, rail-to-rail input and output operational amplifiers specifically designed for portable applications. These devices operate from 1.8 V to 5.5 V, are unity-gain stable, and suitable for a wide range of generalpurpose applications. The class AB output stage is capable of driving $\leq 10\text{k}\Omega$ loads connected to any point between V_{S+} and ground. The input commonmode voltage range includes both rails, and allows the LMV321AI/LMV358AI/LMV324AI family to be used in virtually any single-supply application. Rail-to-rail input and output swing significantly increases dynamic range, especially in low-supply applications, and makes them ideal for driving sampling analog to-digital converters (ADCs).

The LMV321AI/LMV358AI/LMV324AI features 1.2MHz bandwidth and $1\text{V}/\mu\text{s}$ slew rate with only $85\mu\text{A}$ supply current per amplifier, providing good ac performance at very low power consumption. DC applications are also well served with a low input noise voltage of $30\text{nV}/\sqrt{\text{Hz}}$ at 1kHz, low input bias current, and an input offset voltage of $\pm 3.0\text{mV}$ maximum. The typical offset voltage drift is $1\mu\text{V}/^\circ\text{C}$, over the full temperature range the input offset voltage changes only $100\mu\text{V}$ (0.7mV to 0.8mV)

OPERATING VOLTAGE

The LMV321AI/LMV358AI/LMV324AI family is optimized for operation at voltages as low as $+1.8\text{V}$ ($\pm 0.9\text{V}$) and up to $+5.5\text{V}$ ($\pm 2.75\text{V}$). In addition, many specifications apply from -40°C to $+125^\circ\text{C}$. Parameters that vary significantly with operating voltages or temperature are illustrated in the Typical Characteristics graphs.

NOTE: Supply voltages (V_{S+} to V_{S-}) higher than $+10\text{V}$ can permanently damage the device.

RAIL-TO-RAIL INPUT

The input common-mode voltage range of the LMV321AI/LMV358AI/LMV324AI extends 100mV beyond the negative and positive supply rails. This performance is achieved with a complementary input stage: an Nchannel input differential pair in parallel with a Pchannel differential pair. The N-channel pair is active for input voltages close to the positive rail, typically $V_{S+} - 1.4\text{V}$ to the positive supply, whereas the Pchannel pair is active for inputs from 100mV below the negative supply to approximately $V_{S+} - 1.4\text{V}$. There is a small transition region, typically $V_{S+} - 1.2\text{V}$ to $V_{S+} - 1\text{V}$, in which both pairs are on. This 200mV transition region can vary up to 200mV with process variation. Thus, the transition region (both stages on) can range from $V_{S+} - 1.4\text{V}$ to $V_{S+} - 1.2\text{V}$ on the low end, up to $V_{S+} - 1\text{V}$ to $V_{S+} - 0.8\text{V}$ on the high end. Within this transition region, PSRR, CMRR, offset voltage, offset drift, and THD can be degraded compared to device operation outside this region.

The typical input bias current of the LMV321AI/LMV358AI /LMV324AI during normal operation is approximately 5pA . In overdriven conditions, the bias current can increase significantly. The most common cause of an overdriven condition occurs when the operational amplifier is outside of the linear range of operation. When the output of the operational amplifier is driven to one of the supply rails, the feedback loop requirements cannot be satisfied and a differential input voltage develops across the input pins. This differential input voltage results in activation of parasitic diodes inside the front-end input chopping switches that combine with electromagnetic interference (EMI) filter resistors to create the equivalent circuit. Notice that the input bias current remains within specification in the linear region.

INPUT EMI FILTER AND CLAMP CIRCUIT

Figure 1 shows the input EMI filter and clamp circuit. The LMV321AI/LMV358AI/LMV324AI op-amps have internal ESD protection diodes (D1, D2, D3, and D4) that are connected between the inputs and each supply rail. These diodes protect the input transistors in the event of electrostatic discharge and are reverse biased during normal operation. This protection scheme allows voltages as high as approximately 500mV beyond the rails to be applied at the input of either terminal without causing permanent damage. These ESD protection current-steering diodes also provide in-circuit, input overdrive protection, as long as the current is limited to 20mA as stated in the Absolute Maximum Ratings.

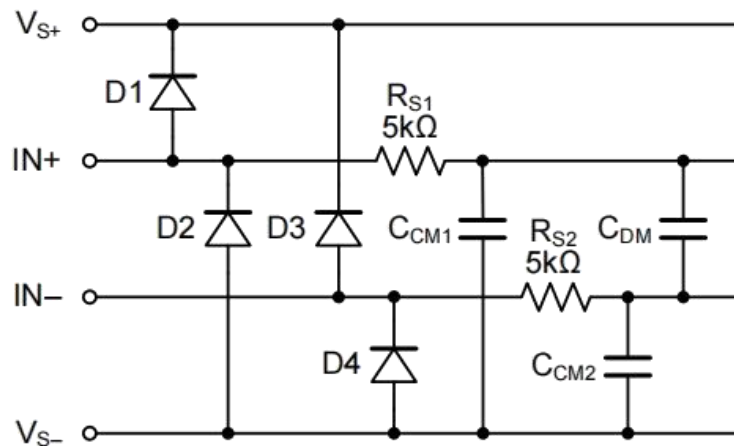

Figure 1. Input EMI Filter and Clamp Circuit

Operational amplifiers vary in susceptibility to EMI. If conducted EMI enters the operational amplifier, the dc offset at the amplifier output can shift from its nominal value when EMI is present. This shift is a result of signal rectification associated with the internal semiconductor junctions. Although all operational amplifier pin functions can be affected by EMI, the input pins are likely to be the most susceptible. The EMI filter of the LMV321AI/358AI/324AI is composed of two 5kΩ input series resistors (R_{S1} and R_{S2}), two common-mode capacitors (C_{CM1} and C_{CM2}), and a differential capacitor (C_{DM}). These RC networks set the -3 dB low-pass cutoff frequencies at 35MHz for common-mode signals, and at 22MHz for differential signals.

RAIL-TO-RAIL OUTPUT

Designed as a micro-power, low-noise op-amp, the LMV321AI/358/324 delivers a robust output drive capability. A class AB output stage with common - source transistors is used to achieve full rail-to-rail output swing capability. For resistive loads up to 50kΩ, the output swings typically to within 3mV of either supply rail regardless of the power-supply voltage applied. Different load conditions change the ability of the amplifier to swing close to the rails. For resistive loads up to 2-kΩ, the output swings typically to within 65mV of the positive supply rail and within 42mV of the negative supply rail.

CAPACITIVE LOAD AND STABILITY

The LMV321AI/LMV358AI/LMV324AI family can safely drive capacitive loads of up to 500pF in any configuration. As with most amplifiers, driving larger capacitive loads than specified may cause excessive overshoot and ringing, or even oscillation. A heavy capacitive load reduces the phase margin and causes the amplifier frequency response to peak. Peaking corresponds to over-shooting or ringing in the time domain. Therefore, it is recommended that external compensation be used if these op-amps must drive a load exceeding 500pF. This compensation is particularly important in the unity-gain configuration, which is the worst case for stability.

A quick and easy way to stabilize the op-amp for capacitive load drive is by adding a series resistor, R_{ISO} , between the amplifier output terminal and the load capacitance, as shown in Figure 2. R_{ISO} isolates the amplifier output and feedback network from the capacitive load. The bigger the R_{ISO} resistor value, the more stable V_{OUT} will be. Note that this method results in a loss of gain accuracy because R_{ISO} forms a voltage divider with the R_L .

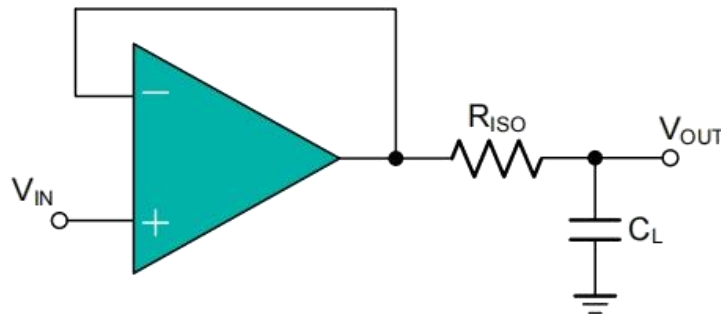

Figure 2. Indirectly Driving Heavy Capacitive Load

An improvement circuit is shown in Figure 3. It provides DC accuracy as well as AC stability. The R_F provides the DC accuracy by connecting the inverting signal with the output.

The C_F and R_{ISO} serve to counteract the loss of phase margin by feeding the high frequency component of the output signal back to the amplifier's inverting input, thereby preserving phase margin in the overall feedback loop.

For no-buffer configuration, there are two others ways to increase the phase margin: (a) by increasing the amplifier's gain, or (b) by placing a capacitor in parallel with the feedback resistor to counteract the parasitic capacitance associated with inverting node.

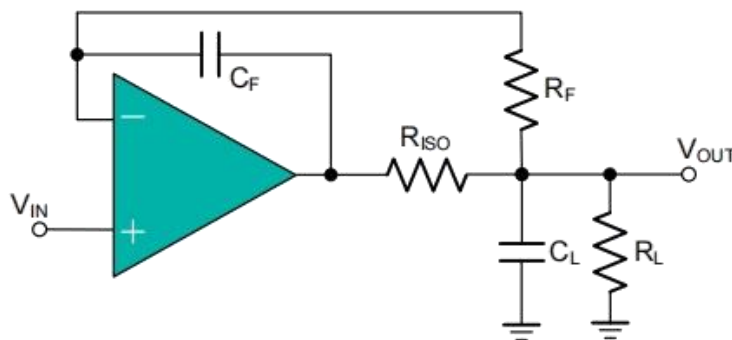

Figure 3. Indirectly Driving Heavy Capacitive Load with DC Accuracy

OVERLOAD RECOVERY

Overload recovery is defined as the time required for the operational amplifier output to recover from a saturated state to a linear state. The output devices of the operational amplifier enter a saturation region when the output voltage exceeds the rated operating voltage, either because of the high input voltage or the high gain. After the device enters the saturation region, the charge carriers in the output devices require time to return back to the linear state. After the charge carriers return back to the linear state, the device begins to slew at the specified slew rate. Thus, the propagation delay in case of an overload condition is the sum of the overload recovery time and the slew time. The overload recovery time for the LMV321AI/LMV358AI/LMV324AI is approximately 2.5 μ s.

EMI REJECTION RATIO

Circuit performance is often adversely affected by high frequency EMI. When the signal strength is low and transmission lines are long, an op-amp must accurately amplify the input signals. However, all opamp pins — the non-inverting input, inverting input, positive supply, negative supply, and output pins — are susceptible to EMI signals. These high frequency signals are coupled into an op-amp by various means, such as conduction, near field radiation, or far field radiation. For example, wires and printed circuit board (PCB) traces can act as antennas and pick up high frequency EMI signals.

Amplifiers do not amplify EMI or RF signals due to their relatively low bandwidth. However, due to the nonlinearities of the input devices, op-amps can rectify these out of band signals. When these high frequency signals are rectified, they appear as a dc offset at the output.

The LMV321AI/LMV358AI/LMV324AI have integrated EMI filters at their input stage. A mathematical method of measuring EMIRR is defined as follows:

$$\text{EMIRR} = 20 \log (V_{\text{IN_PEAK}} / \Delta V_{\text{OS}})$$

INPUT-TO-OUTPUT COUPLING

To minimize capacitive coupling, the input and output signal traces should not be parallel. This helps reduce unwanted positive feedback.

MAXIMIZING PERFORMANCE THROUGH PROPER LAYOUT

To achieve the maximum performance of the extremely high input impedance and low offset voltage of the LMV321AI/LMV358AI/LMV324AI, care is needed in laying out the circuit board. The PCB surface must remain clean and free of moisture to avoid leakage currents between adjacent traces. Surface coating of the circuit board reduces surface moisture and provides a humidity barrier, reducing parasitic resistance on the board. The use of guard rings around the amplifier inputs further reduces leakage currents. Figure 4 shows proper guard ring configuration and the top view of a surface-mount layout. The guard ring does not need to be a specific width, but it should form a continuous loop around both inputs. By setting the guard ring voltage equal to the voltage at the non-inverting input, parasitic capacitance is minimized as well. For further reduction of leakage currents, components can be mounted to the PCB using Teflon standoff insulators.

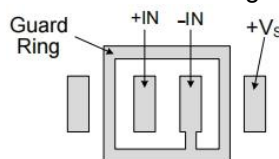

Figure 4. Use a guard ring around sensitive pins

Other potential sources of offset error are thermoelectric voltages on the circuit board. This voltage, also called Seebeck voltage, occurs at the junction of two dissimilar metals and is proportional to the temperature of the junction. The most common metallic junctions on a circuit board are solder-to-board trace and solder-to-component lead. If the temperature of the PCB at one end of the component is different from the temperature at the other end, the resulting Seebeck voltages are not equal, resulting in a thermal voltage error.

This thermocouple error can be reduced by using dummy components to match the thermoelectric error source. Placing the dummy component as close as possible to its partner ensures both Seebeck voltages are equal, thus canceling the thermocouple error. Maintaining a constant ambient temperature on the circuit board further reduces this error. The use of a ground plane helps distribute heat throughout the board and reduces EMI noise pickup.

Physical Dimensions

SOT-23-5

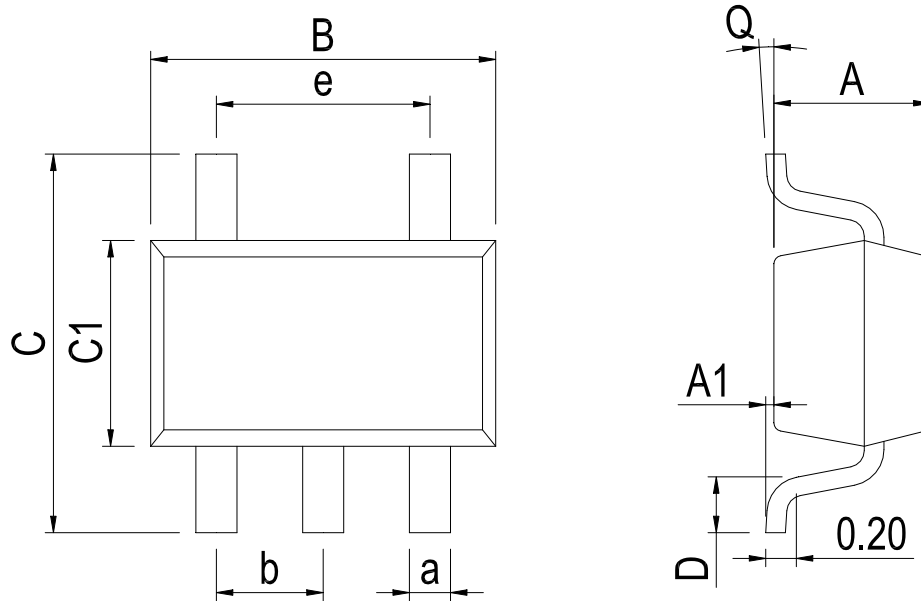

Dimensions In Millimeters(SOT-23-5)

Symbol:	A	A1	B	C	C1	D	Q	a	b	e
Min:	1.05	0.00	2.82	2.65	1.50	0.30	0°	0.30	0.95 BSC	1.90 BSC
Max:	1.15	0.15	3.02	2.95	1.70	0.60	8°	0.40		

SC70-5

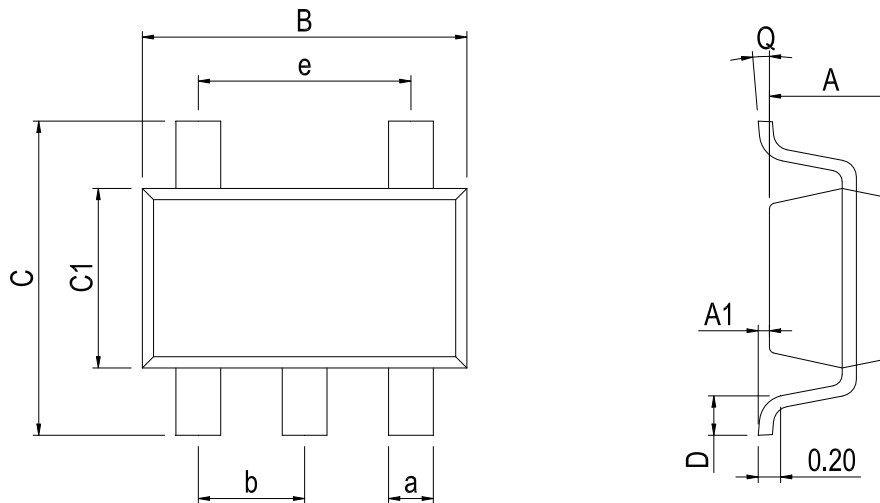

Dimensions In Millimeters(SC70-5)

Symbol:	A	A1	B	C	C1	D	Q	a	b	e
Min:	0.90	0.00	2.00	2.15	1.15	0.26	0°	0.15	0.65 BSC	1.30 BSC
Max:	1.00	0.15	2.20	2.45	1.35	0.46	8°	0.35		

Physical Dimensions

MSOP-8

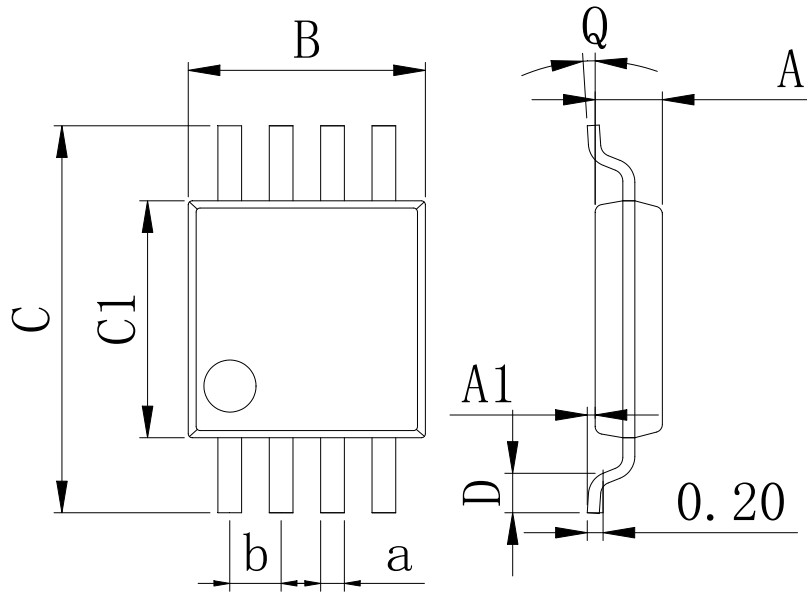

Dimensions In Millimeters(MSOP-8)

Symbol:	A	A1	B	C	C1	D	Q	a	b
Min:	0.80	0.05	2.90	4.75	2.90	0.35	0°	0.25	0.65 BSC
Max:	0.90	0.20	3.10	5.05	3.10	0.75	8°	0.35	

SOP-8

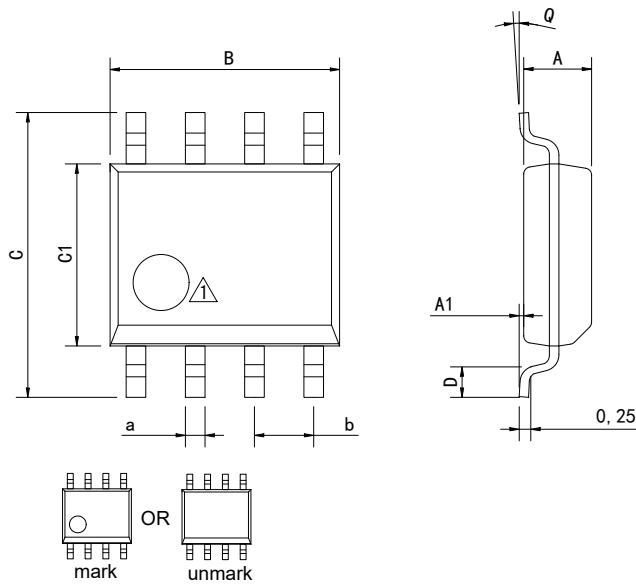

△ Package top mark may be in lower left corner or unmark

Dimensions In Millimeters(SOP-8)

Symbol:	A	A1	B	C	C1	D	Q	a	b
Min:	1.35	0.05	4.90	5.80	3.80	0.40	0°	0.35	1.27 BSC
Max:	1.55	0.20	5.10	6.20	4.00	0.80	8°	0.45	

Physical Dimensions

DIP-8

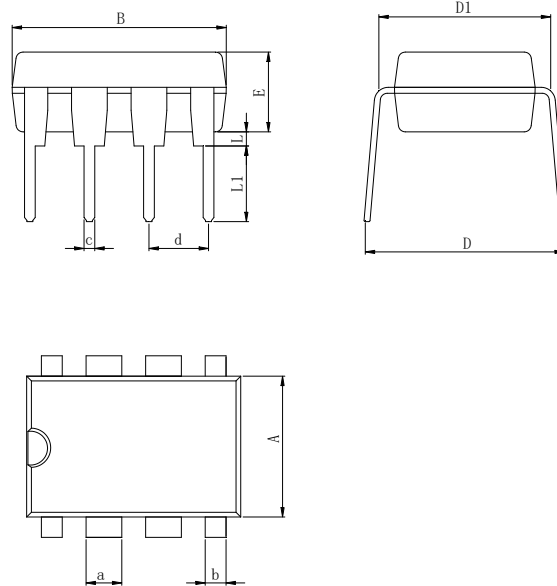
Dimensions In Millimeters(DIP-8)

Symbol:	A	B	D	D1	E	L	L1	a	b	c	d
Min:	6.10	9.00	8.10	7.42	3.10	0.50	3.00	1.50	0.85	0.40	2.54 BSC
Max:	6.68	9.50	10.9	7.82	3.55	0.70	3.60	1.55	0.90	0.50	

SOP-14

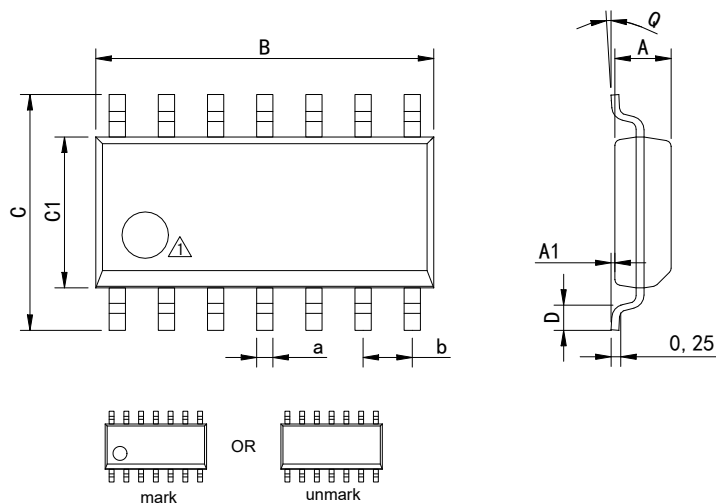

△ Package top mark may be in lower left corner or unmark

Dimensions In Millimeters(SOP-14)

Symbol:	A	A1	B	C	C1	D	Q	a	b
Min:	1.35	0.05	8.55	5.80	3.80	0.40	0°	0.35	1.27 BSC
Max:	1.55	0.20	8.75	6.20	4.00	0.80	8°	0.45	

Physical Dimensions

TSSOP-14

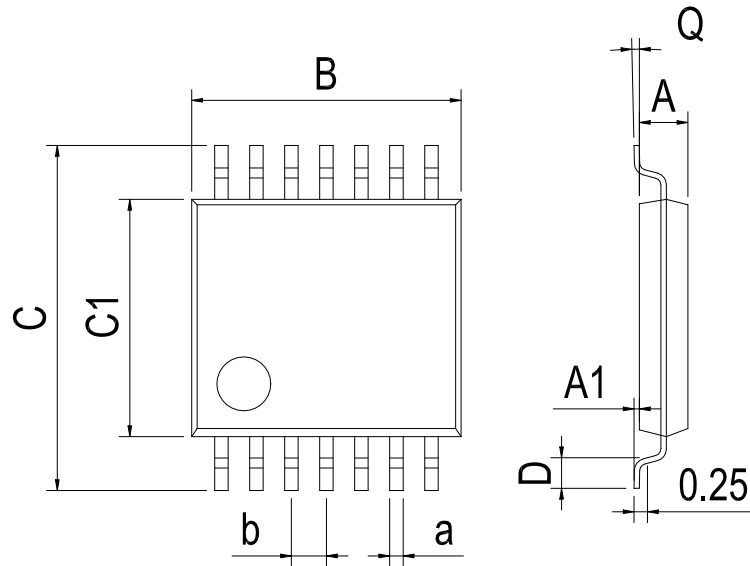

Dimensions In Millimeters(TSSOP-14)

Symbol:	A	A1	B	C	C1	D	Q	a	b
Min:	0.85	0.05	4.90	6.20	4.30	0.40	0°	0.20	0.65 BSC
Max:	0.95	0.20	5.10	6.60	4.50	0.80	8°	0.25	

DFN-8 2*2

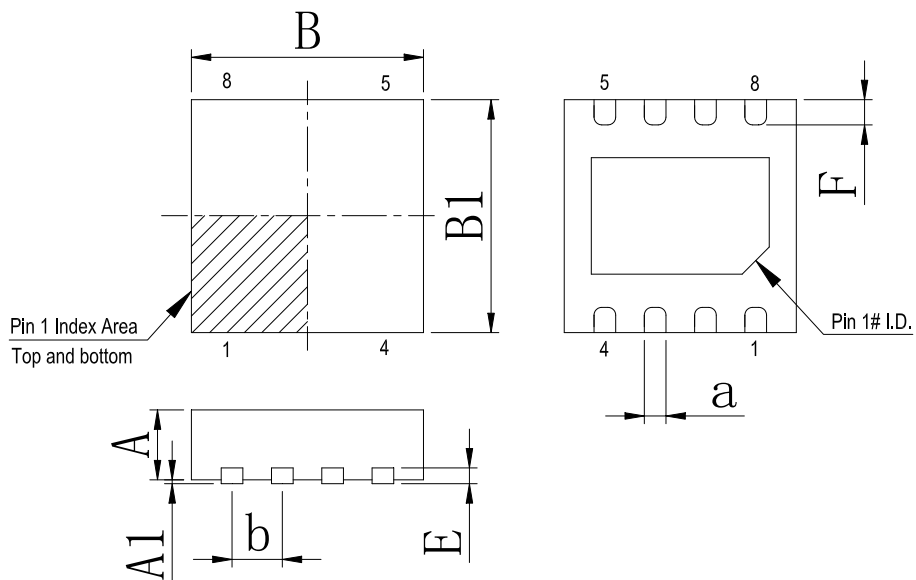

Dimensions In Millimeters(DFN-8 2*2)

Symbol:	A	A1	B	B1	E	F	a	b
Min:	0.85	0	1.90	1.90	0.15	0.25	0.18	0.50TYP
Max:	0.95	0.05	2.10	2.10	0.25	0.45	0.30	

Physical Dimensions

TSSOP-8 (4.4*3.0)

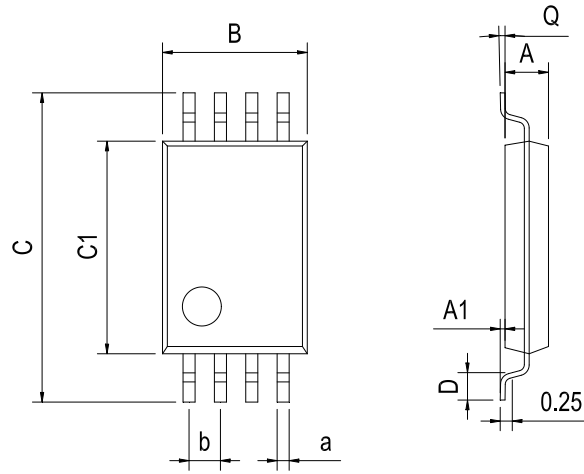

Dimensions In Millimeters(TSSOP-8)									
Symbol:	A	A1	B	C	C1	D	Q	a	b
Min:	0.85	0.05	2.90	6.20	4.30	0.40	0°	0.20	0.65 BSC
Max:	0.95	0.20	3.10	6.60	4.50	0.80	8°	0.25	

SOT-23-8

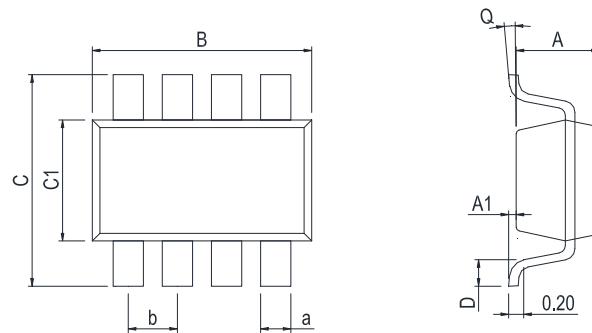

Dimensions In Millimeters(SOT-23-8)									
Symbol:	A	A1	B	C	C1	D	Q	a	b
Min:	1.00	0.00	2.82	2.65	1.50	0.30	0°	0.30	0.65 BSC
Max:	1.15	0.15	3.02	2.95	1.70	0.60	8°	0.50	

Physical Dimensions

QFN-16 3*3

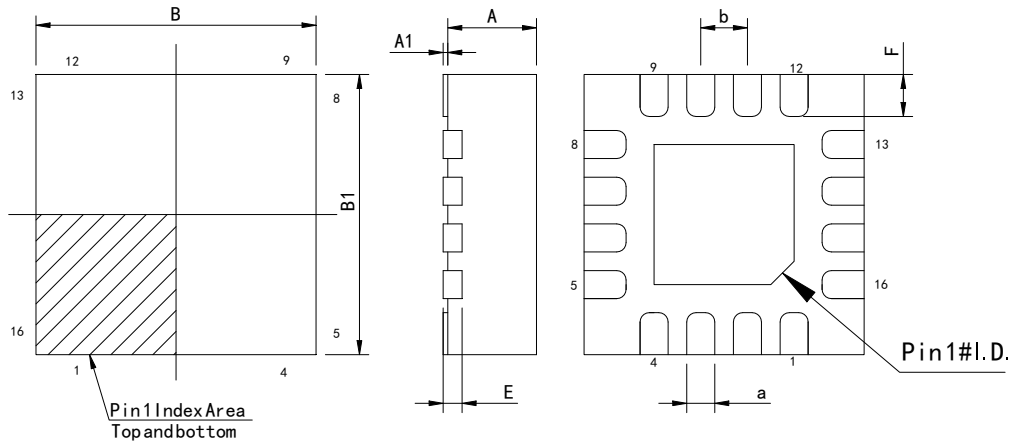

Dimensions In Millimeters(QFN-16 3*3)

Symbol:	A	A1	B	B1	E	F	a	b
Min:	0.85	0	2.90	2.90	0.15	0.25	0.18	0.50TYP
Max:	0.95	0.05	3.10	3.10	0.25	0.45	0.30	

QSOP16

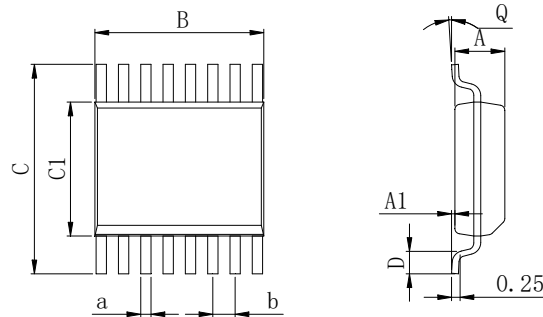

Dimensions In Millimeters(QSOP16)

Symbol:	A	A1	B	C	C1	D	Q	a	b
Min:	1.35	0.05	4.80	5.80	3.80	0.40	0°	0.20	0.635 BSC
Max:	1.55	0.20	5.10	6.20	4.00	0.80	8°	0.25	

Physical Dimensions

DIP14

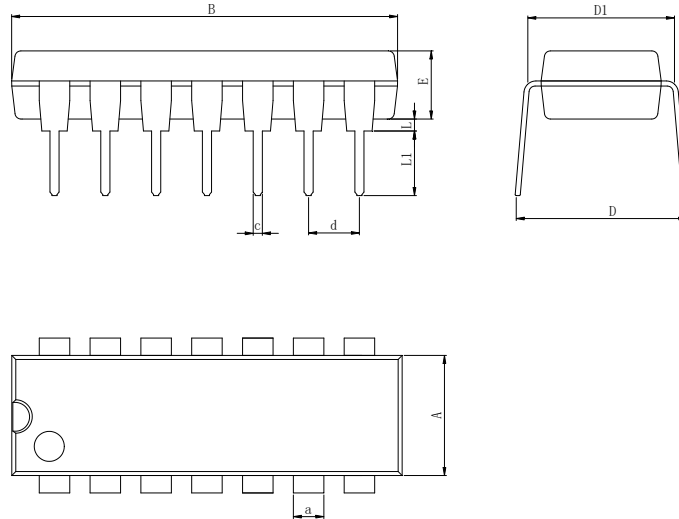

Dimensions In Millimeters(DIP14)										
Symbol:	A	B	D	D1	E	L	L1	a	c	d
Min:	6.10	18.94	8.10	7.42	3.10	0.50	3.00	1.50	0.40	2.54 BSC
Max:	6.68	19.56	10.9	7.82	3.55	0.70	3.60	1.55	0.50	

DFN-8 3*3

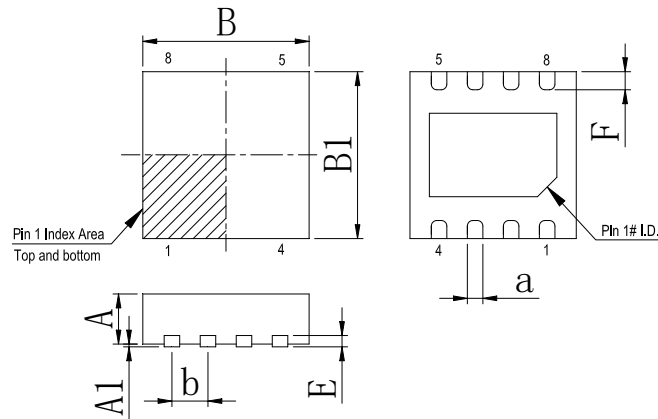

Dimensions In Millimeters(DFN-8 3*3)								
Symbol:	A	A1	B	B1	E	F	a	b
Min:	0.85	0.00	2.90	2.90	0.20	0.30	0.20	0.65 BSC
Max:	0.95	0.05	3.10	3.10	0.25	0.50	0.34	

Revision History

REVISION NUMBER	DATE	REVISION	PAGE
V1.0	2015-11	New	1-20
V1.1	2025-3	Document Reformatting	1-20
V1.2	2025-10	Update important statements	20
V1.3	2026-3	Update SOT-23-8 Pin Configurations	2

IMPORTANT STATEMENT:

Huaguan Semiconductor reserves the right to change products and services offered without prior notice. Customers should obtain the latest relevant information before placing orders and verify that such information is current and complete. Huaguan Semiconductor assumes no responsibility or liability for altered documents.

Customers are responsible for complying with safety standards and implementing safety measures when using Huaguan Semiconductor products in system design and end-product manufacturing. You assume full responsibility for: selecting the appropriate Huaguan Semiconductor products for your application; designing, validating, and testing your application; and ensuring that your application complies with applicable standards and all other safety, security, or other requirements. This is to prevent potential risks that may lead to personal injury or property damage.

Huaguan Semiconductor products are not approved for use in life support, military, aerospace, or other high-risk applications. Huaguan products are neither intended nor warranted for use in such systems or equipment. Any failure or malfunction may lead to personal injury or severe property damage. Such applications are deemed "Unsafe Use." Unsafe Use includes, but is not limited to: surgical and medical equipment, nuclear energy control equipment, aircraft or spacecraft instruments, control or operation of vehicle power, braking, or safety systems, traffic signal instruments, all types of safety devices, and any other applications intended to support or sustain life. Huaguan Semiconductor shall not be liable for consequences resulting from Unsafe Use in these fields. Users must independently evaluate and assume all risks. Any issues, liabilities, or losses arising from the use of products beyond their approved applications shall be solely borne by the user. Users may not claim any compensation from Huaguan Semiconductor based on these terms. If any third party claims against Huaguan Semiconductor due to such Unsafe Use, the user shall compensate Huaguan Semiconductor for all resulting damages and liabilities.

Huaguan Semiconductor provides technical and reliability data (including datasheets), design resources (including reference designs), application or other design advice, web tools, safety information, and other resources for its semiconductor products. However, no guarantee is made that these resources are free from defects, and no express or implied warranties are provided. The use of testing and other quality control techniques is limited to Huaguan Semiconductor's quality assurance scope. Not all parameters of each device are tested.

Huaguan Semiconductor's documentation authorizes you to use these resources only for developing applications related to the products described herein. You are not granted rights to any other intellectual property of Huaguan Semiconductor or any third party. Any other reproduction or display of these resources is strictly prohibited. You shall fully indemnify Huaguan Semiconductor and its agents against any claims, damages, costs, losses, and liabilities arising from your use of these resources. Huaguan Semiconductor shall not be held responsible.