

RoHS

REVISIONS					
REV.	ECN NO.	LOCATION	DESCRIPTION	DATE	DESIGN
A0	N/A		INITIAL RELEASE	2024.09.20	

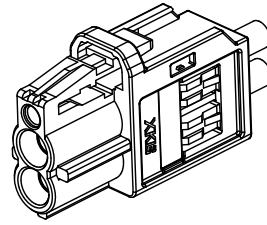

3D View

Specifications (规格):

- Impedance (特性阻抗): 50Ω;
- Frequency (工作频率): DC~6GHz;
- VSWR (电压驻波比): 1.40 @DC~2GHz;
1.50 @2~3GHz;
1.60 @3~6GHz;
- Insulation resistance (绝缘阻抗): ≥100MΩ;
- Dielectric withstand voltage (介质耐电压): 800V AC;
- Mating cycles (耐久性): ≥25 cycles;
- Retention force latch (保持力): ≥110N;
- Temperature range (使用温度): -40°C~+105°C;

9. PART NO.:

XMORLF2S3-NA26-X

Code: A~Z

10. Housing P/N:

XMHF2-PT16-X

Code: A~Z

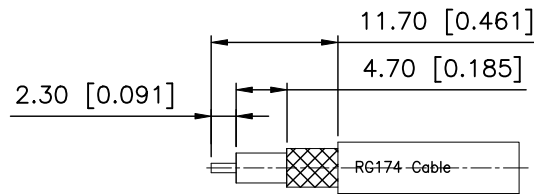
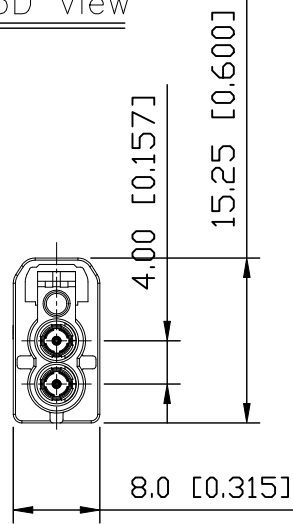
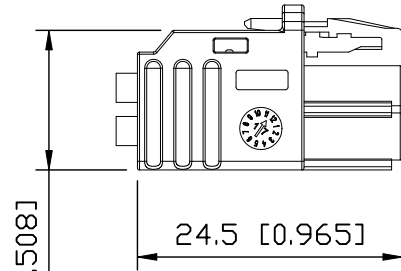
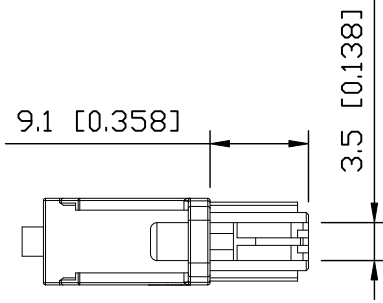

RECOMMENDED CABLE STRIPPING DIM'S

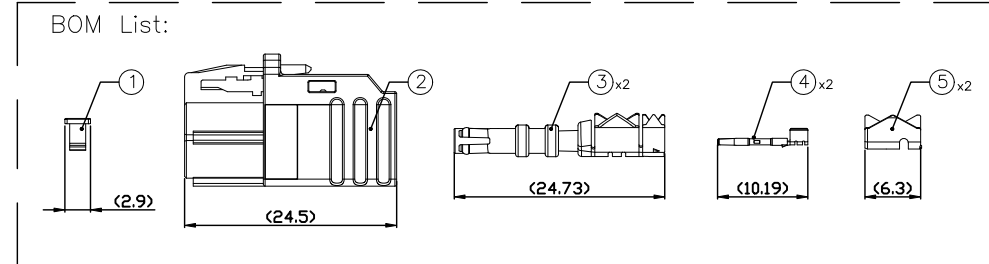

ANGULAR	±5°
X.	±0.50
X.x	±0.30
X.xx	±0.20
X.xxx	±0.10
UNSPECIFIED TOLERANCES	

5	XKS3-PBT03	Outer Ferrule	Copper Alloy	Tin PLATED	2 PCS	5K PCS/R
4	XMTF3-PBGN610	Center Conductor	Copper Alloy	Gold PLATED	2 PCS	5K PCS/R
3	XMBF3-PBT204	Outer Conductor	Copper Alloy	Tin PLATED	2 PCS	
2	XMHF2-PT16-X	Housing	PBT		1 PC	
1	XMC0-PTY04	Secondary Lock	PBT		1 PC	
NO.	P/N	NAME	MATERIAL	FINISH (Contact)	Q'TY	Note

www.helloxkb.com www.helloxkb.cn www.xk-dg.cn



DESIGN	希文	VIEW:	
CHECKED		UNIT:	mm/in
APPROVED		SIZE:	A4

MODEL TYPE:	Vertical, Double MINI FAKRA Female Connector for RG174 Cable
PART NO.:	XMORLF2S3-NA26-X
DWG NO.:	X-XMORLF2S3-NA26-X

XKB INDUSTRIAL PRECISION CO., LIMITED

SCALE	PAGE	REVISION
N/A	1/2	A0

Code List:

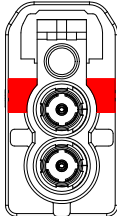
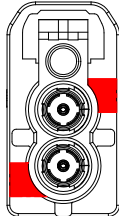
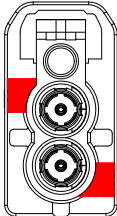
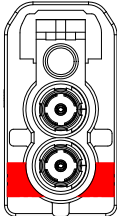
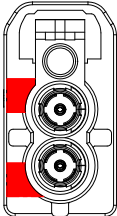
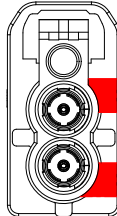
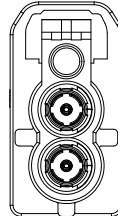
Colde							
	A	B	C	D	E	F	Z
Color/RAL-No.	Black/9005	White/9001	Blue/5005	Bordeaux/4004	Green/6002	Brown/8011	Water Blue/5021
PART NO.	XMORLF2S3-NA26-A	XMORLF2S3-NA26-B	XMORLF2S3-NA26-C	XMORLF2S3-NA26-D	XMORLF2S3-NA26-E	XMORLF2S3-NA26-F	XMORLF2S3-NA26-Z

NOTE: ALL RIGHTS RESERVED,BANNED COPY!

ANGLAR	±5°
X.	±0.40
X.x	±0.30
X.xx	±0.20
X.xxx	±0.15
UNSPECIFIED TOLERANCES	



DESIGN	希文
CHECKED	
APPROVED	

VIEW:	
UNIT:	mm/in
SIZE:	A4

MODEL TYPE:	Vertical Double MINI FAKRA Female Connector for RG174 Cable		
PART NO.:	XMORLF2S3-NA26-X		
DWG NO.:	X-XMORLF2S3-NA26-X		

XKB INDUSTRIAL PRECISION CO.,LIMITED

SCALE	PAGE	REVISION
N/A	2/2	A0