

NCH75R130S



N-Channel Silicon Carbide MOSFET

Voltage: 750 Volts	Current: 19.5 Ampers	Package: TO-252
---------------------------	-----------------------------	------------------------

Features

- NH'S Advanced Silicon Carbide MOSFET Technology
- High Blocking Voltage And Low Capacitances
- High-Speed Switching For Very Low Switching Losses
- Excellent Qg*Rds(on) Product(FOM)

Typical Applications

- High Voltage DC/DC Converters
- Adaptor And Charger
- Battery Chargers And Motor Drives
- LED Drives And LED Lighting

Product Summary

V _{DS} Min.@T _j	750	V
I _D Min.@Ta	19.5	A
RDS(ON)(TYP)@18V,T _j =25°C	130	mΩ

Diagram:

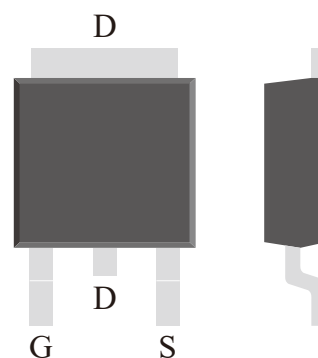

Polarity:

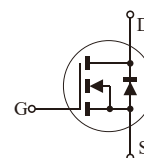

***100% UIS TESTED**
***100% ΔVDS TESTED**

Absolute Maximum Ratings (Ta=25°C Unless Otherwise Specified)

Parameter	Test Conditions	Symbol	Ratings	Unit
Drain-Source Voltage		V _{DS}	750	V
Gate-Source Voltage		V _{GS} MAX.	-10/+22	V
		V _{GS} O.P.	0/+18	
Continuous Drain Current (Note 1)	Ta= 25 °C	I _D	19.5	A
	Ta= 100 °C		15.6	
Drain Current-Pulse (Note 1)	T _j < 175 °C	I _{DM}	34	A
Maximum Power Dissipation Power	Ta= 25 °C	P _D	76	W
Dissipation Derating Factor Above 25°C	Ta= 100 °C		38	
Derating Factor		D _F	0.51	W/°C
Avalanche Current,Single Pulse (Note 1)	L= 0.5 mH	I _{AS}	11.6	A
Single Pulse Avalanche Energy (Note 1) Test Circuit & Waveform See Fig.22	L= 0.5 mH IAS= 11.6 A, RG= 10.0 Ω Starting T _j =25 °C, VG = 18.0 V	E _{AS}	34	mJ

Thermal Characteristics (Ta=25°C Unless Otherwise Specified)

Parameter	Test Conditions	Symbol	Typ.	Unit
Junction Temperature		T _J	-55 to 175	°C
Storage Temperature Range		T _{STD}	-55 to 175	°C
Thermal Resistance Junction To Ambient With Steady-State	Still Air Environment With Ta=25°C	R _{θJA}	50	°C/W
Thermal Resistance Junction-Case With Steady-State	Device Mounted On 1 in2 FR-4 Board With 2oz. Copper	R _{θJC}	1.98	

Notes: 1.Pulse Width Limited By Max. Junction Temperature. (See Fig. 19).

NCH75R130S
N-Channel Silicon Carbide MOSFET

Electrical Characteristics (Ta=25°C Unless Otherwise Specified)

Parameter	Test Conditions	Symbol	Min.	Typ.	Max.	Unit	
Static Off Characteristics							
Drain-Source Breakdown Voltage	VGS=0V, ID=100uA	BV _{DSS}	750	--	--	V	
Zero Gate Voltage Drain Current	VDS= 0 V, VGS=0V, Tj=25°C	I _{DSS}	--	0.1	20	uA	
	VDS= 750 V, VGS=0V, Tj=175°C		--	5	--		
Gate To Source Leakage Current	VGS= 22 V, VDS=0V	I _{GSS}	--	--	250	nA	
Source To Gate Leakage Current	VGS= -10 V, VDS=0V	I _{SGS}	--	--	250	nA	
Forward Transconductance	ID= 11.3 A, VDS= 20 V	g _{fs}	--	4.3	--	S	
Static On Characteristics							
Gate Threshold Voltage	VGS= VDS, ID=10mA, Tj=25°C	V _{GS(TH)}	3	3.8	5	V	
	VGS= VDS, ID=10mA, Tj=175°C		--	2.7	--		
Drain-Source On Resistance	ID= 11.3 A, VGS= 18.0 V, Tj=25°C	R _{DS(ON)}	--	130	145	mΩ	
	ID= 11.3 A, VGS= 18.0 V, Tj=175°C		--	146	162		
	ID= 11.3 A, VGS= 15.0 V, Tj=25°C		--	169	218		
	ID= 11.3 A, VGS= 15.0 V, Tj=175°C		--	154	198		
Dynamic Characteristics							
Input Capacitance	VDS= 50 V	C _{iss}	--	415	--	pF	
Output Capacitance	VGS= 0 V	C _{oss}	--	30	--	pF	
Reverse Transfer Capacitance	F= 1 MHz	C _{rss}	--	4.2	--	pF	
Gate Resistance	VGS=0V, VDS=0V, Freq.=1MHz	R _g	--	31	--	Ω	
Switching Paramters (Test Circuit & Waveform See Fig.20)							
Turn-On Delay Time	VDS= 400 V ID= 11.3 A	Tj=25°C	t _{d(on)}	--	29	--	ns
		Tj=175°C	--	27.6	--		
Turn-On Rise Time	VGS= 0/+18 V RG= 10.0 Ω	Tj=25°C	t _r	--	12	--	ns
		Tj=175°C	--	11.4	--		
Turn-Off Delay Time	L= 600 μH	Tj=25°C	t _{d(off)}	--	22.5	--	ns
		Tj=175°C	--	21.4	--		
Turn-Off Rise Time		Tj=25°C	t _f	--	10.5	--	ns
		Tj=175°C	--	8.9	--		
Turn-On Switching Loss		Tj=25°C	E _{on}	--	92.5	--	μJ
		Tj=175°C	--	87.9	--		
Turn-Off Switching Loss		Tj=25°C	E _{off}	--	74.5	--	μJ
		Tj=175°C	--	68.4	--		
Total Switching Energy		Tj=25°C	E _{tot}	--	167.0	--	μJ
		Tj=175°C	--	156.3	--		

NCH75R130S



N-Channel Silicon Carbide MOSFET

Electrical Characteristics (Ta=25°C Unless Otherwise Specified)

Parameter	Test Conditions	Symbol	Min.	Typ.	Max.	Unit
Gate Charge Paramters (Test Circuit & Waveform See Fig.21)						
Total Gate Charge	VDS= 400 V	Q _g	--	15	--	nC
Gate-Source Charge	VGS= 18 V	Q _{gs}	--	5.5	--	nC
Gate-Drain Charge	ID= 11.3 A	Q _{gd}	--	2.5	--	nC
Drain-Source Diode Characteristics And Maximum Ratings (Test Circuit & Waveform See Fig.23)						
Max. Diode Forward Cuurent	Tj= 25 °C	I _s	--	--	19.5	A
tp Limited by Tj(max)	Tj= 100 °C		--	--	15.6	
Max. Pulsed Forward Cuurent		I _{SM}	--	--	29	A
Diode Forward Voltage	ID= 3.5 A, VGS=-0V	Tj=25°C	--	3.3	--	V
		Tj=175°C	--	2.8	--	
Reverse Recovery Time	IS= 9.7 A di/dt= 1000.0 A/us	Tj=25°C	--	26	--	ns
		Tj=175°C	--	29.4	--	
Reverse Recovery Charge	VGS= 0.0 V VDS= 400 V	Tj=25°C	--	125	--	nC
		Tj=175°C	--	143.8	--	
Reverse Recovery Current		Tj=25°C	--	10.0	--	A
		Tj=175°C	--	9.8	--	
Reverse Recovery Energy		Tj=25°C	--	52.0	--	μJ
		Tj=175°C	--	57.5	--	

NCH75R130S

N-Channel Silicon Carbide MOSFET



Typical Characteristics Curves

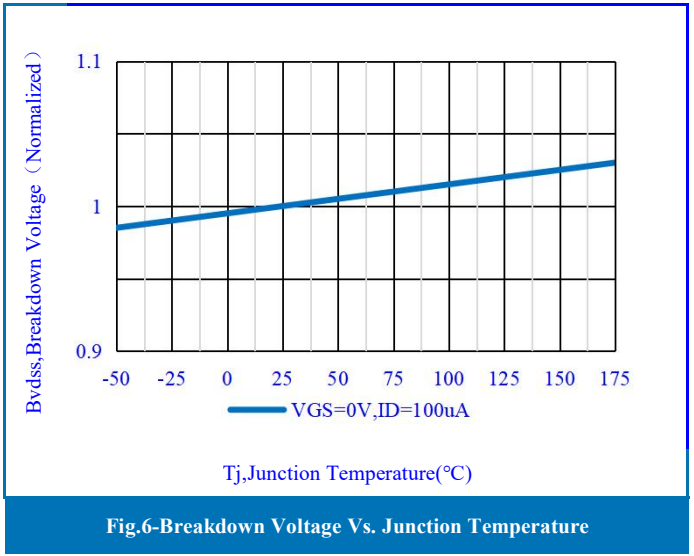
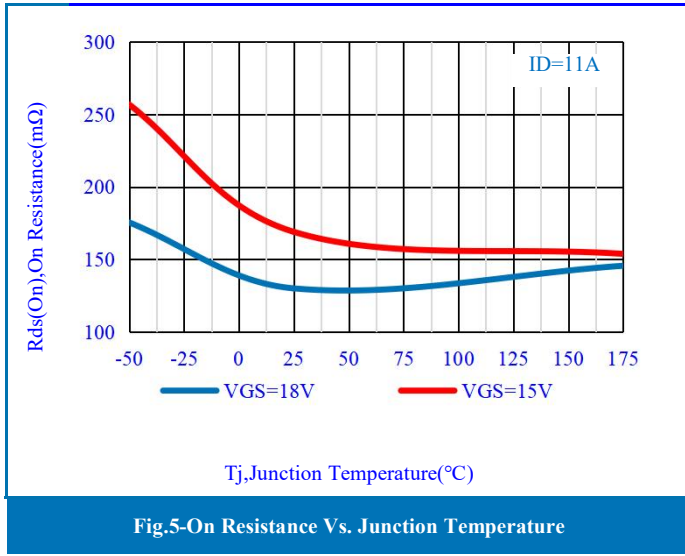
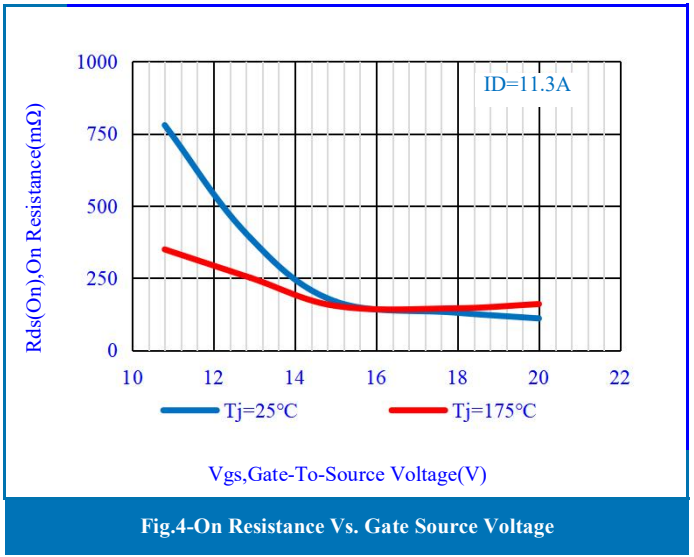
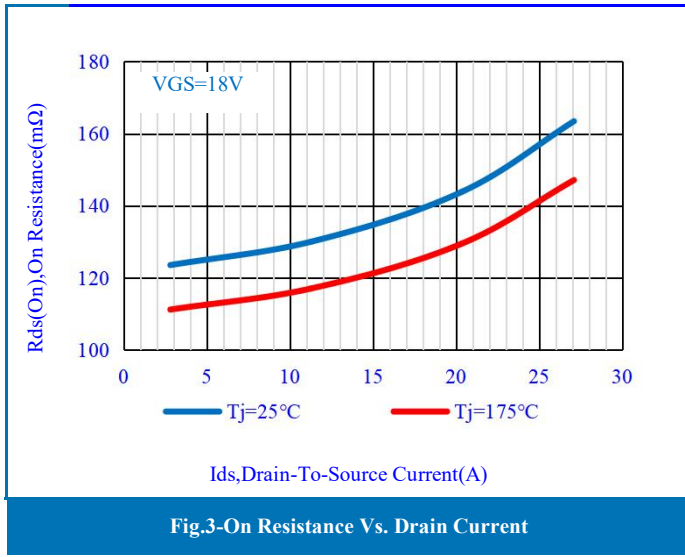
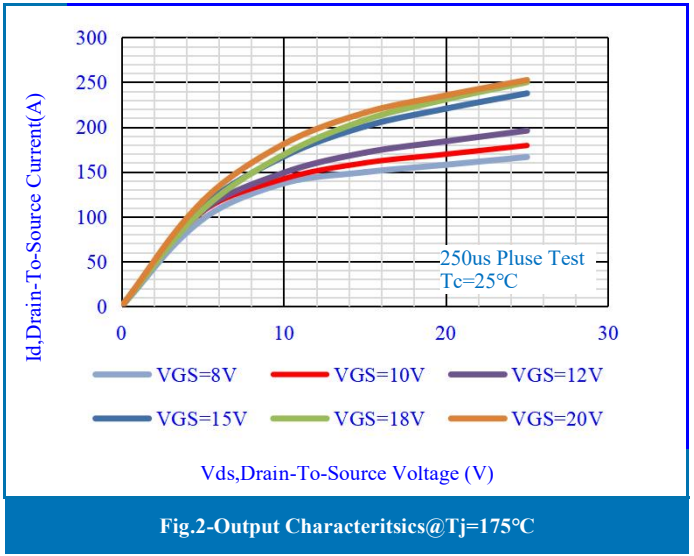
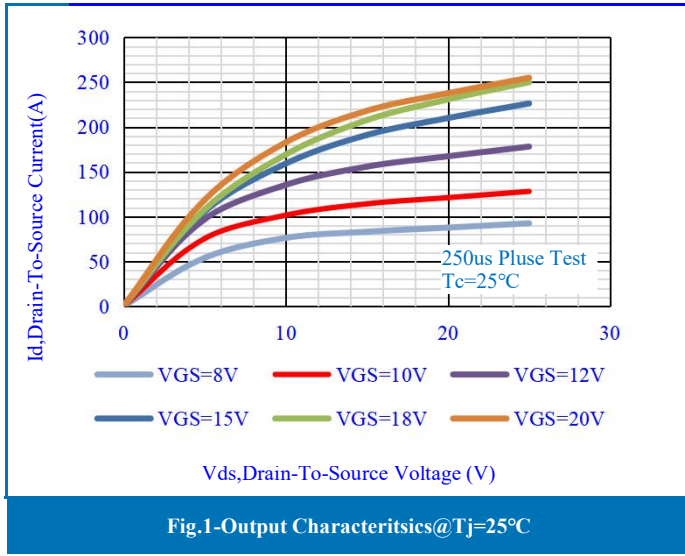

NCH75R130S

N-Channel Silicon Carbide MOSFET



Typical Characteristics Curves

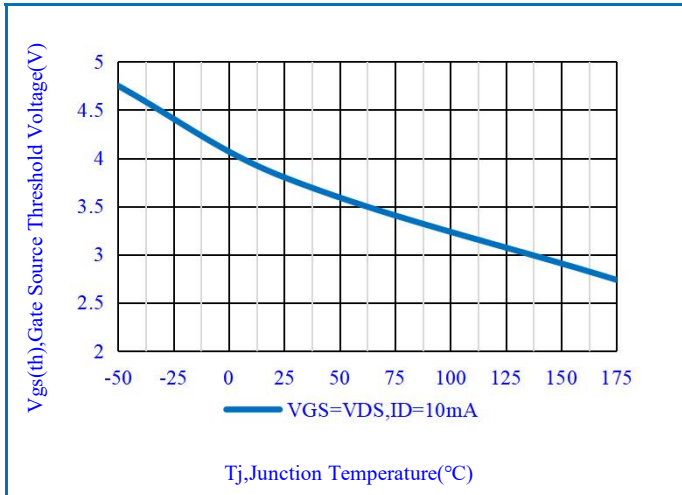

Fig.7-Gate Source Threshold Voltage Vs. Junction Temperature

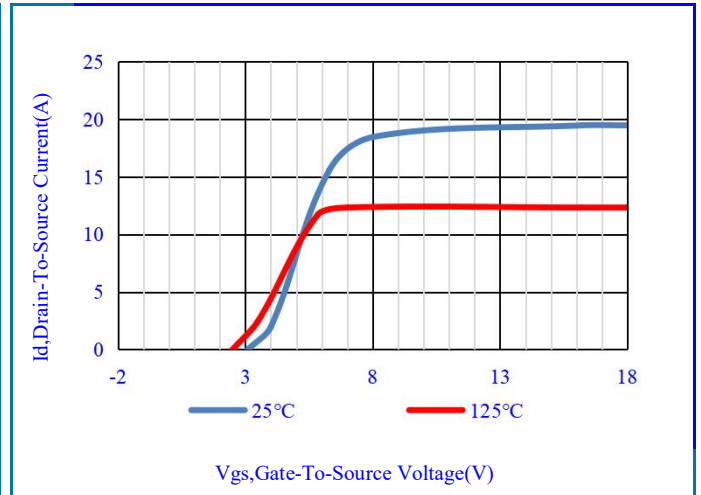

Fig.8-Transfer Characteristics

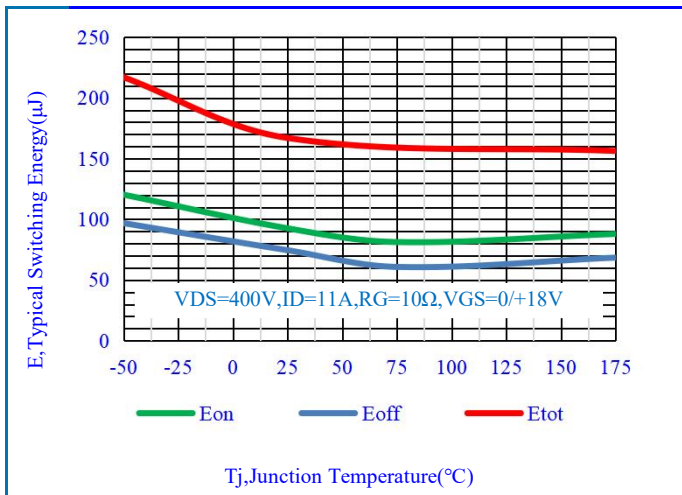

Fig.9-Typical Switching Energy Vs. Junction Temperature

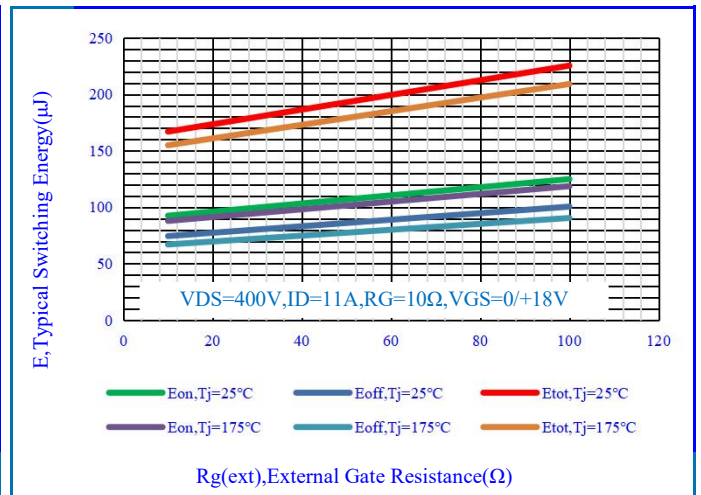

Fig.10-Typical Switching Energy Vs. External Gate Resistance

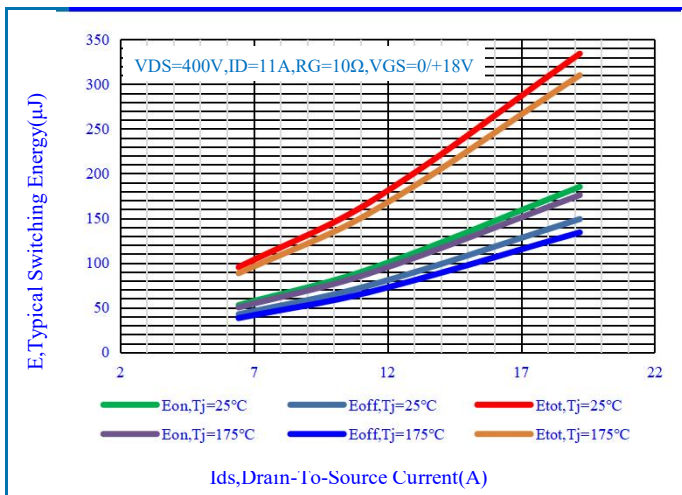

Fig.11-Typical Switching Energy Vs. Drain Source Current

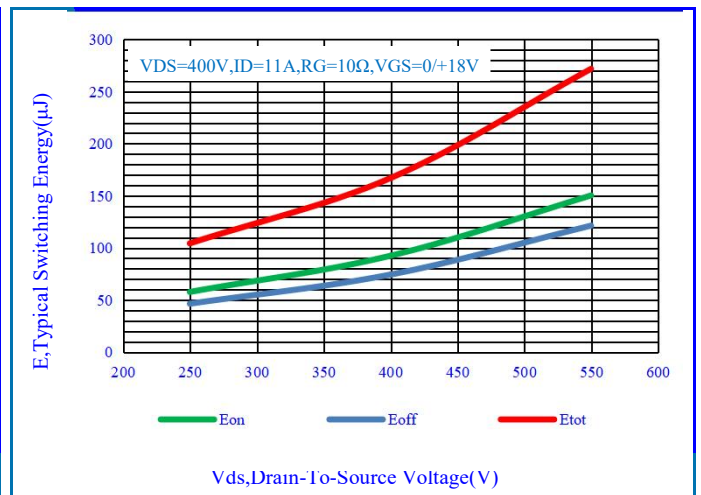

Fig.12-Typical Switching Energy Vs. Drain Source Voltage

NCH75R130S

N-Channel Silicon Carbide MOSFET



Typical Characteristics Curves

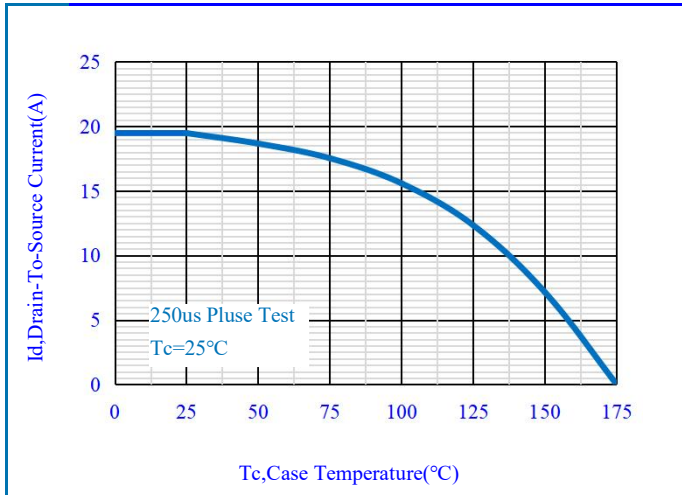

Fig.13-Maximum Continuous Drain Current Vs. Case Temperature

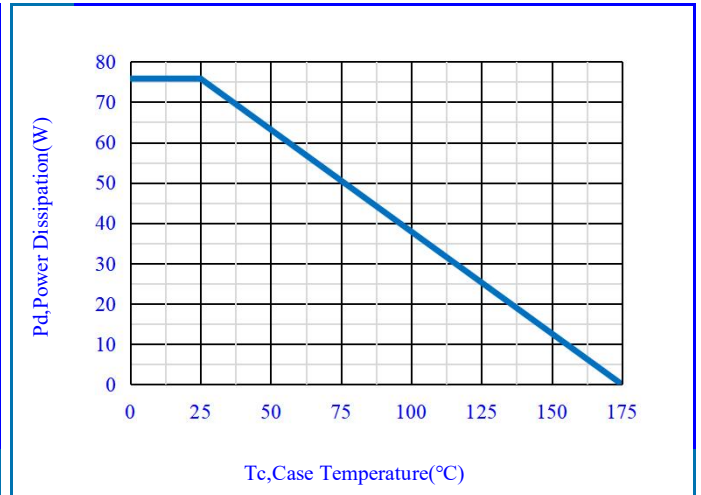

Fig.14-Maximum Power Dissipation Vs. Case Temperature

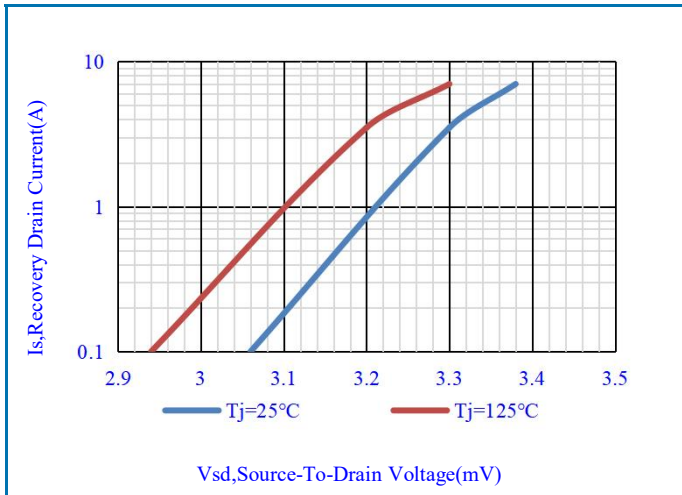

Fig.15-Source-To-Drain Diode Forward Voltage

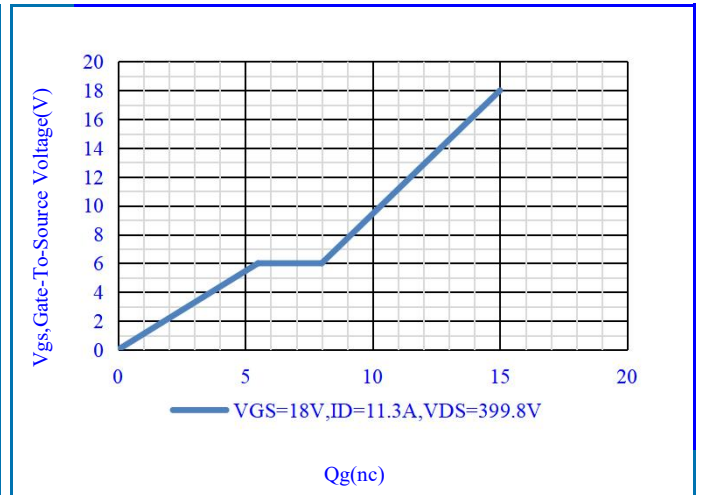

Fig.16-Gate Charge Waveform

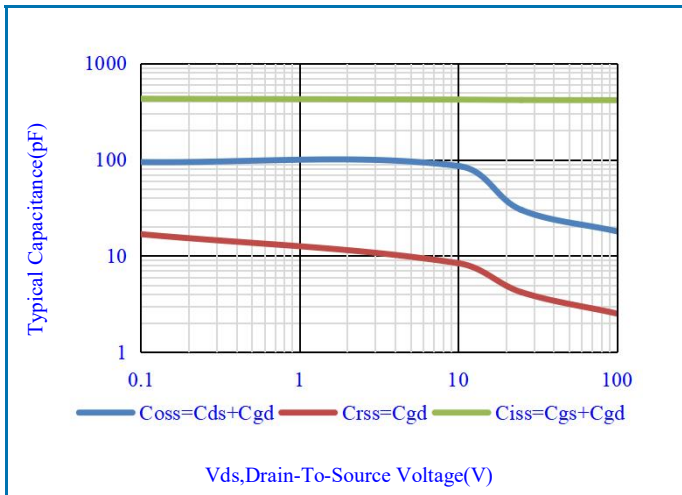

Fig.17-Typical Capacitance Vs. Drain-To-Source Voltage

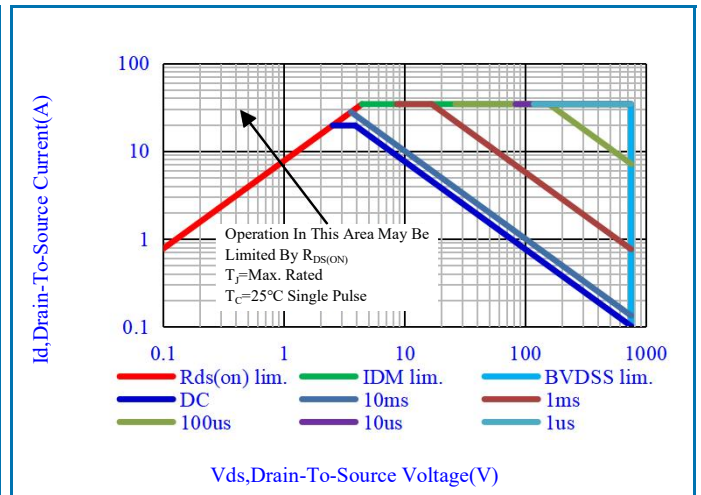

Fig.18-Maximum Safe Operating Area(SOA)

NCH75R130S

N-Channel Silicon Carbide MOSFET



Typical Characteristics Curves

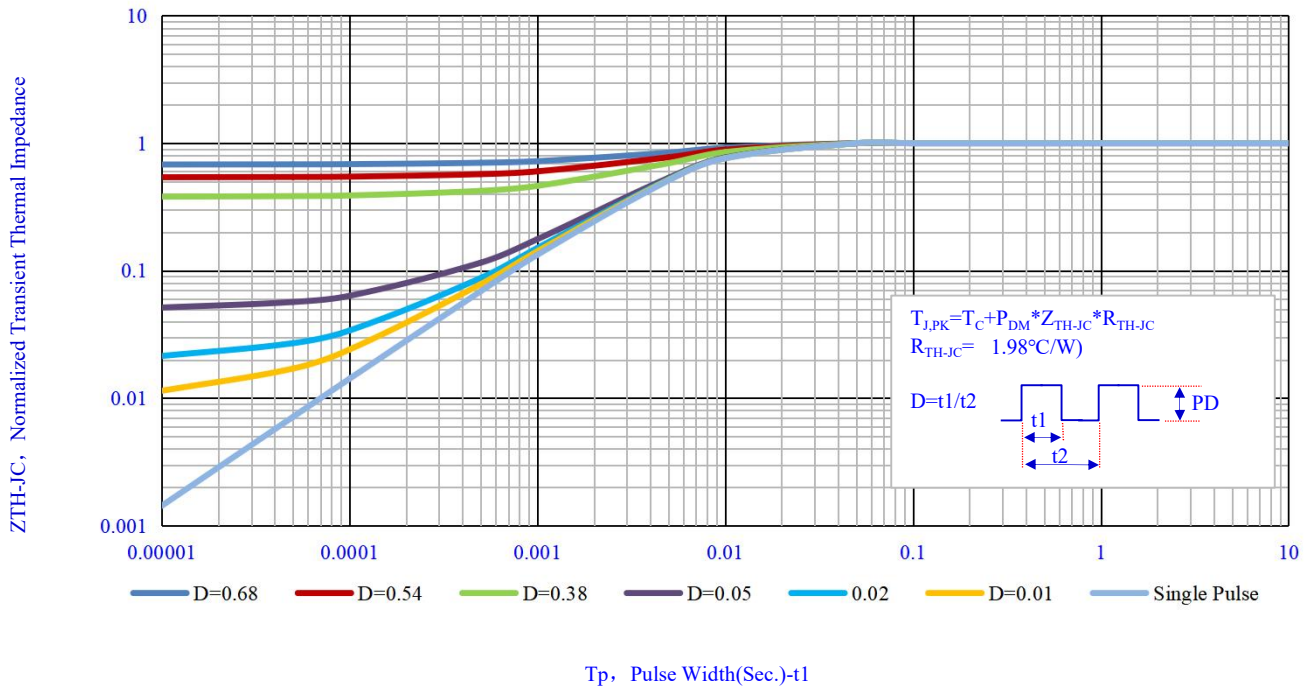

Fig.19- Normalized Maximum Transient Thermal Impedance Vs.Pulse Width

Test Circuit & Waveform

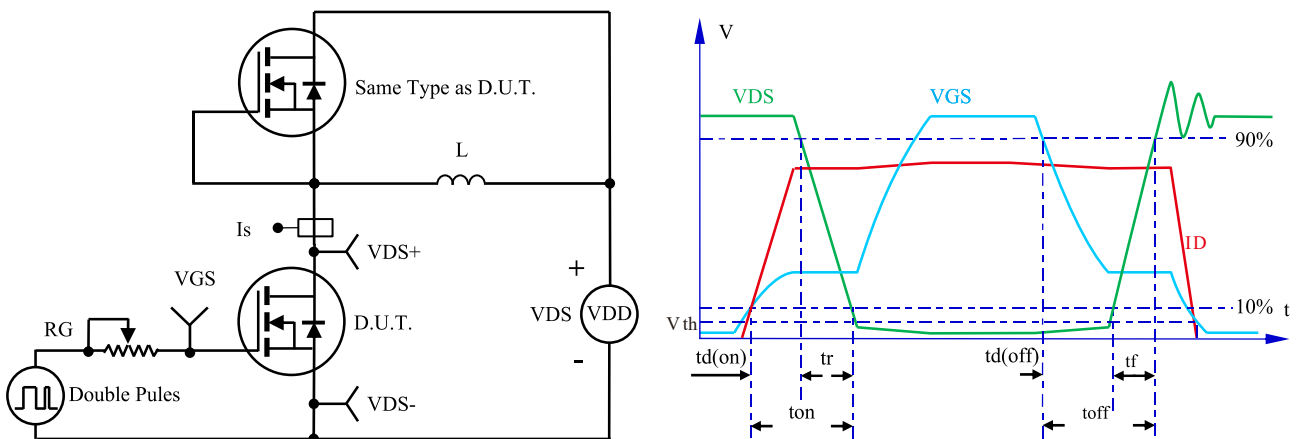

Fig.20- Inductive Switching Test Circuit & Waveform

NCH75R130S

N-Channel Silicon Carbide MOSFET



Test Circuit & Waveform

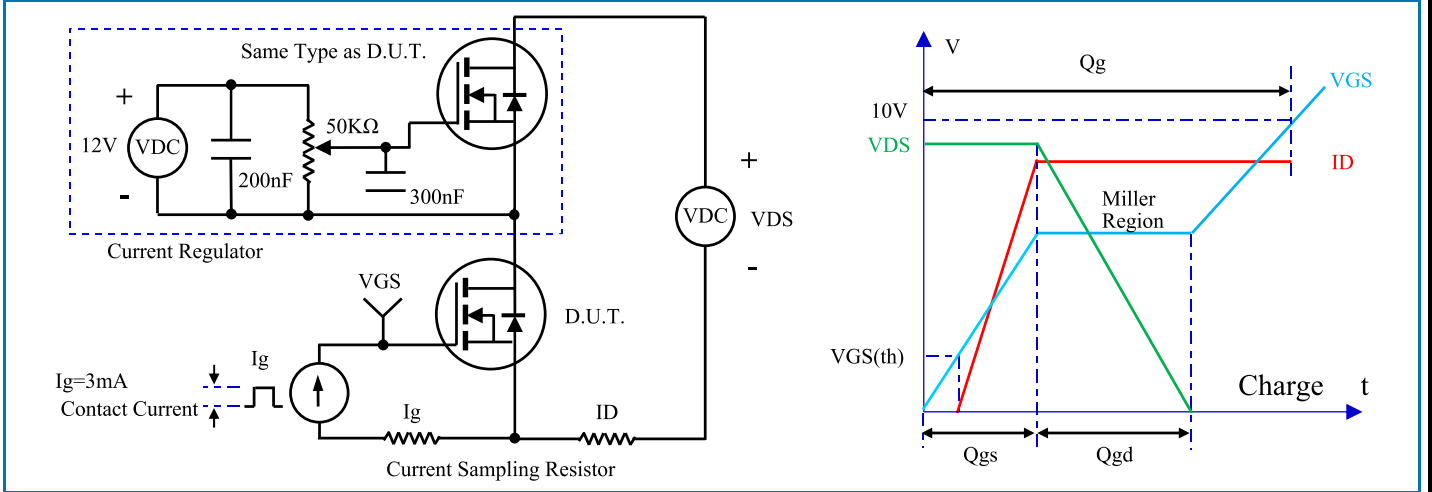

Fig.21-Gate Charge Test Circuit & Waveform

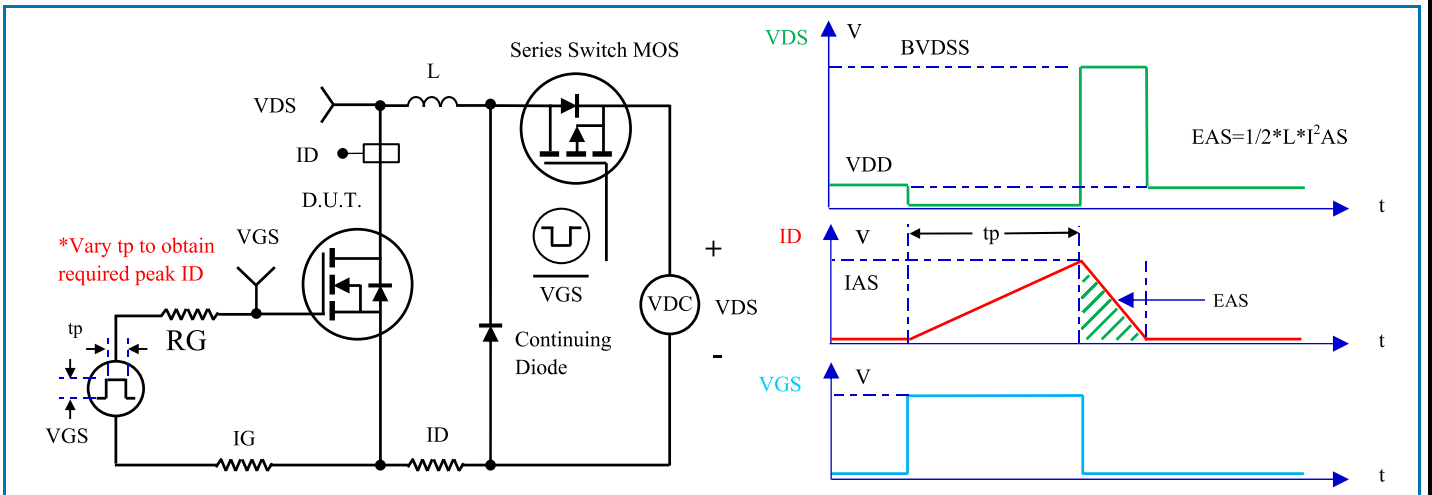

Fig.22- Unclamped Inductive Switching (UIS) Test Circuit & Waveform

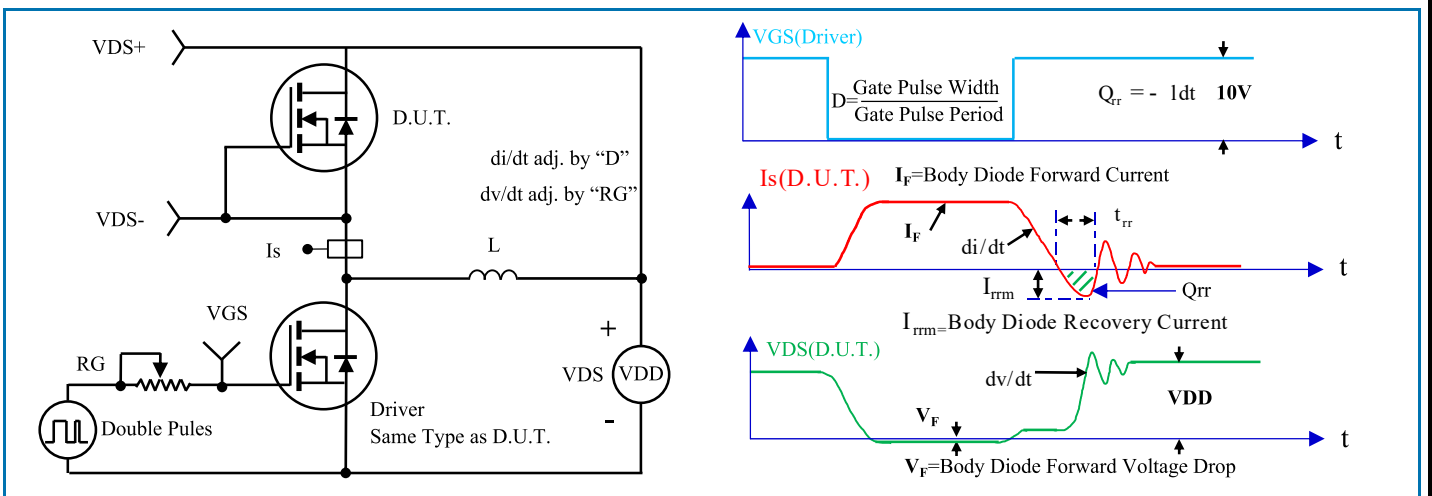

Fig.23- Diode Recovery Test Circuit & Waveform

NCH75R130S



N-Channel Silicon Carbide MOSFET

OUTLINE DRAWINGS

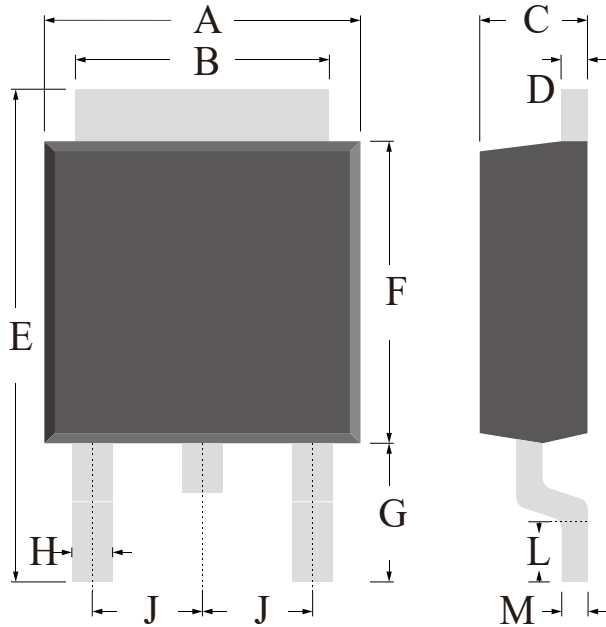

TO-252

OUTLINE DIMENSIONS						
Dim.	Milimeters			Inches		
	Min.	Typ.	Max.	Min.	Typ.	Max.
A	6.10	-	7.10	0.2402	-	0.2795
B	4.80	-	5.80	0.1890	-	0.2283
C	1.95	-	2.55	0.0768	-	0.1004
D	0.35	-	0.75	0.0138	-	0.0295
E	9.25	-	10.75	0.3642	-	0.4232
F	5.60	-	6.60	0.2205	-	0.2598
G	2.50	-	3.10	0.0984	-	0.1220
H	0.65	-	1.05	0.0256	-	0.0413
J	2.10	-	2.50	0.0827	-	0.0984
L	1.00	-	1.40	0.0394	-	0.0551
M	0.35	-	0.75	0.0138	-	0.0295

RECOMMENDED LAYOUT DRAWINGS

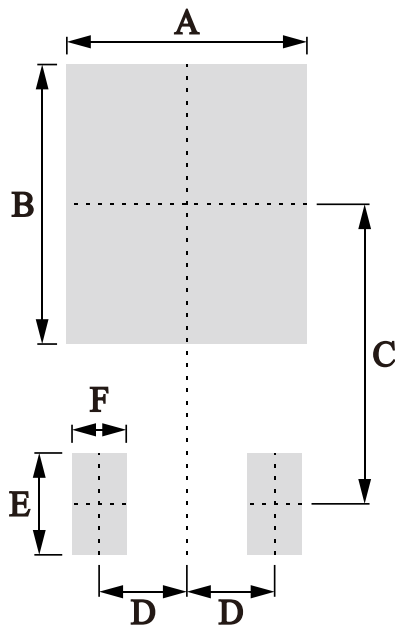

TO-252

OUTLINE DIMENSIONS						
Dim.	Milimeters			Inches		
	Min.	Typ.	Max.	Min.	Typ.	Max.
A	-	6.09	-	-	0.2398	-
B	-	7.57	-	-	0.2980	-
C	-	6.64	-	-	0.2614	-
D	-	2.30	-	-	0.0906	-
E	-	2.76	-	-	0.1087	-
F	-	1.42	-	-	0.0559	-

NCH75R130S

N-Channel Silicon Carbide MOSFET



MARKING INFORMATION



MARKING INSTRUCTIONS

NH=Nihang Trademark
 FF=Product Line Code,According To Actual Changes
 YWW=Date Code,According To Actual Changes
 LLWWF=Inernal Code,According To Actual Changes
 NCH75R130S=Model

PACKAGING

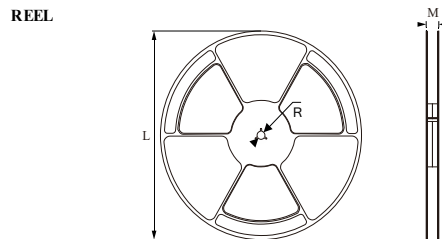
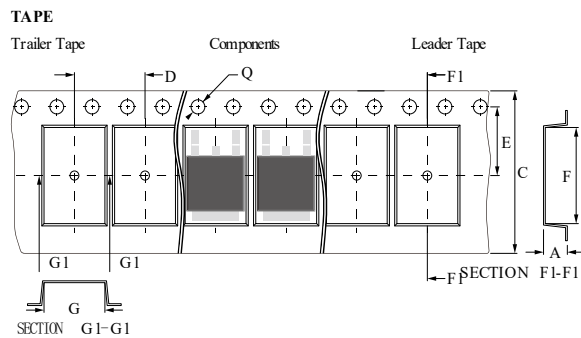

TO-252

OUTLINE DIMENSIONS						
Dim.	Milimeters			Inches		
	Min.	Typ.	Max.	Min.	Typ.	Max.
TAPE						
A	2.60	-	2.80	0.1024	-	0.1102
C	15.60	-	16.40	0.6142	-	0.6457
D	7.70	-	8.30	0.3031	-	0.3268
E	7.30	-	7.70	0.2874	-	0.3031
F	10.20	-	10.80	0.4016	-	0.4252
G	6.70	-	7.10	0.2638	-	0.2795
Q Φ	1.40	-	1.60	0.0551	-	0.0630
REEL						
L	328.00	-	332.00	12.913	-	13.071
R	12.00	-	14.00	0.4724	-	0.5512
M	19.40	-	23.40	0.7638	-	0.9213

PACKING INFORMATION

Package Type	Package Code	Product Weight Approx(g/Pcs)	Package Method	Quantity (Pcs/Min. Pack.)	Quantity (Pcs/Inner Box)	Quantity (Pcs/Carton)
TO-252	P1	0.321	13" Reel	2500	5000	30000
TO-252	P2	0.321	13" Reel	2500	2500	25000

NCH75R130S

N-Channel Silicon Carbide MOSFET



Recommended wave soldering condition

Product	Peak Temperature	Soldering Time
Pb-free devices	260 +0/-5 °C	5 +1/-1 seconds

Recommended temperature profile for IR reflow

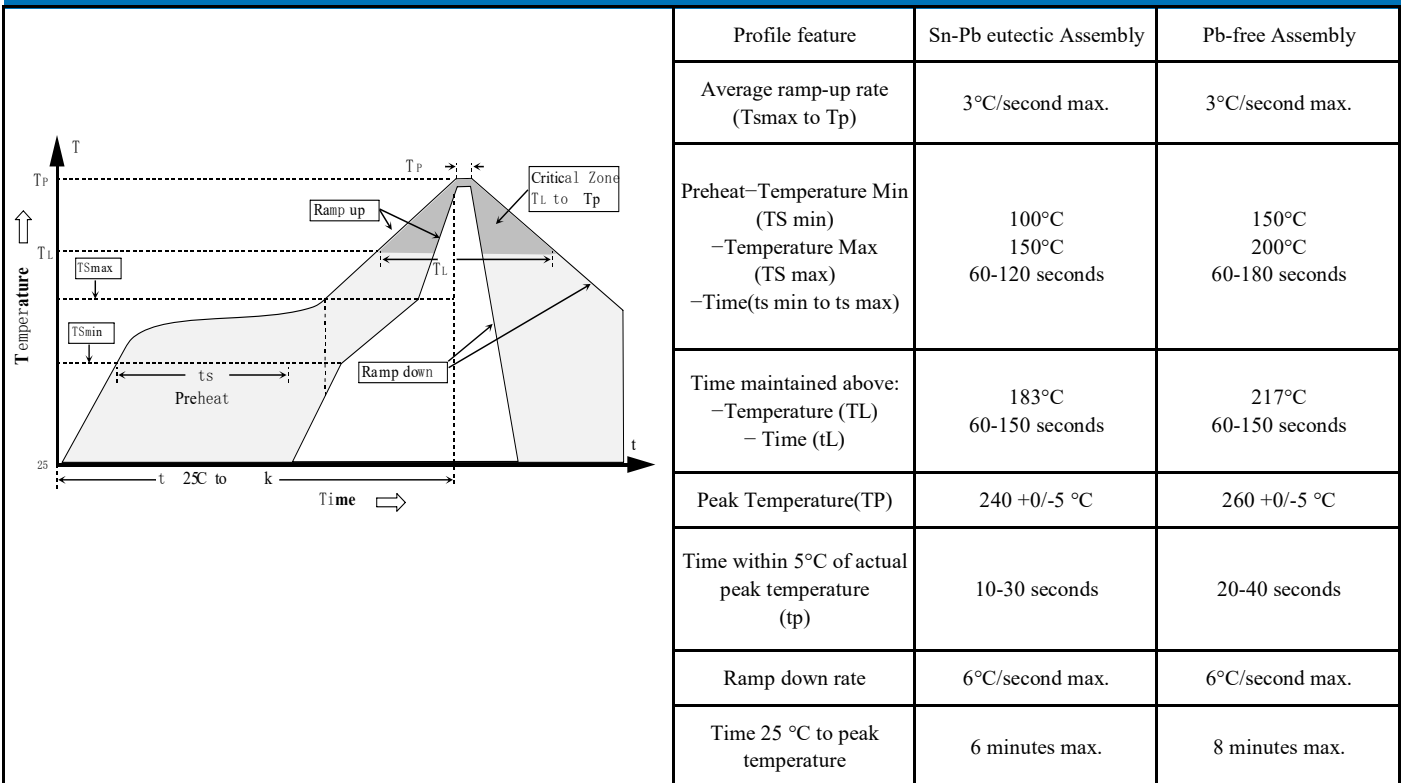

Note : All temperatures refer to topside of the package, measured on the package body surface.

Disclaimer

- Reproducing and modifying information of the document is prohibited without permission from Nihang Electronics Technology Co., LTD
- Nihang Electronics Technology Co., LTD. reserves the rights to make changes of the content herein the document anytime without notification.
- Nihang Electronics Technology Co., LTD. disclaims any and all liability arising out of the application or use of any product including damages incidentally and consequentially occurred.
- Nihang Electronics Technology Co., LTD. does not assume any and all implied warranties,including warranties of fitness for particular purpose,non-infringement and merchantability.
- Applications shown on the herein document are examples of standard use and operation.Customers are responsible in comprehending the suitable use in particular applications.Nihang Electronics Technology Co., LTD.makes no representation or warranty that such applications will be suitable for the specified use without further testing or modification.
- The products shown herein are not designed and authorized for equipments requiring high level of reliability or relating to human life and for any applications concerning life-saving or life-sustaining,such as medical instruments,transportation equipment,aerospae machinery et cetera.Customers usin or selling these products for use in such applications do so at their own rish and agree to fully indemnify Nihang Electronics Technology Co., LTD.for any damages resulting resulting from such improper use or sale.
- When the appearance of the product and chip size does not change, in order to product the customer. quality, change the internal structure and the production process Nihang can not notify

NCH75R130S

N-Channel Silicon Carbide MOSFET



Specification Revision History

Rev.	Date	Changed Items	Pre-Changed Content	Changed Content
A/1	2025-10-20	First Issue		
		Blank Below		