

# MSKSEMI 美森科

SEMICONDUCTOR



ESD



TVS



TSS



MOV



GDT



PLED

## TPS61040DBVR-MS

产品手册

## GENERAL DESCRIPTION

The TPS61040DBVR-MS is a constant frequency, 5-pin SOT23 current mode step-up converter intended for small, low power applications.

The TPS61040DBVR-MS switches at 1.2MHz and allows the use of tiny, low cost capacitors and inductors 2mm or less in height. Internal soft-start results in small inrush current and extends battery life.

The TPS61040DBVR-MS operates from an input voltage as low as 2.5V and can generate 28V at up to 100mA from a 5V supply.

The TPS61040DBVR-MS features automatic shifting to pulse frequency modulation mode at light loads.

The TPS61040DBVR-MS includes under-voltage lockout, current limiting, and thermal overload protection to prevent damage in the event of an output overload. The TPS61040DBVR-MS is available in a small 5-pin SOT-23 package.



## FEATURES

- Integrated 0.5Ω Power MOSFET
- 40μA Quiescent Current
- 2.5V to 5.5V Input Voltage
- 1.2MHz Fixed Switching Frequency
- Internal 1.5A Switch Current Limit
- Adjustable Output Voltage
- Internal Compensation
- Up to 28V Output Voltage
- Automatic Pulse Frequency Modulation Mode at Light Loads
- Over 85% Efficiency
- Available in a 5-Pin SOT23-5 Package

## APPLICATIONS

- OLED Biasing
- LCD Bias Supply
- White LED Driver
- PDAs
- Digital Still Cameras

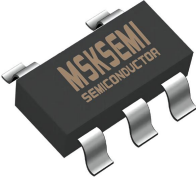
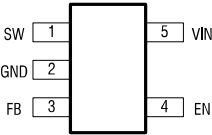
## DEVICE SUMMARY, PIN AND PACKAGES

SOT-23-5	PIN DESCRIPTION	MARKING
	 <p>5-LEAD PLASTIC SOT-23  <math>T_{JMAX} = 160^{\circ}C</math>, <math>\theta_{JA} = 250^{\circ}C/W</math>, <math>\theta_{JC} = 130^{\circ}C/W</math></p>	

**PIN DESCRIPTION**

Pin Name	Pin Number	Description
SW	1	Power Switch Output. SW is the drain of the internal MOSFET switch. Connect the power inductor and output rectifier to SW. SW can swing between GND and 28V.
GND	2	Ground Pin
FB	3	Feedback Input. The FB voltage is 1.25V. Connect a resistor divider to FB.
EN	4	Regulator On/Off Control Input. A high input at EN turns on the converter, and a low input turns it off. When not used, connect EN to the input supply for automatic startup.
VIN	5	Input Supply Pin. Must be locally bypassed.

**ORDER INFORMATION**

PACKAGE	ORDERABLE DEVICE	PACKING QTY
SOT-23-5	TPS61040DBVR-MS	3000PCS

**TYPICAL APPLICATION**

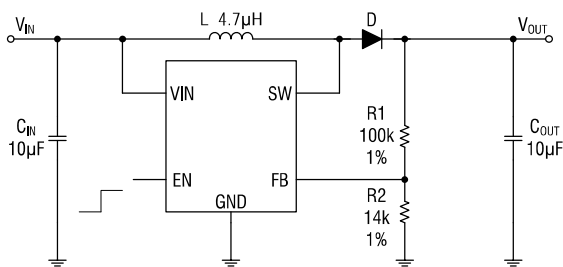
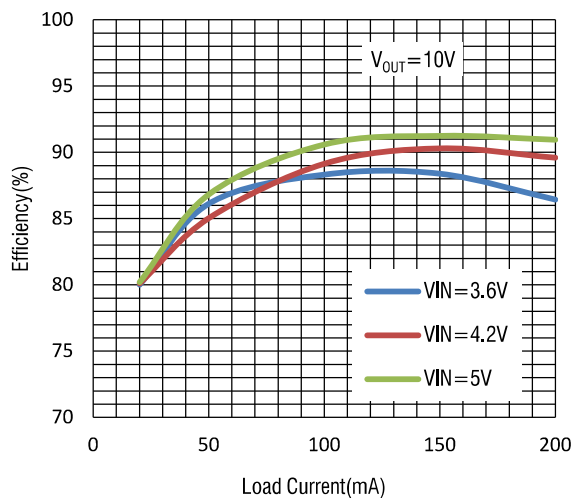

Figure 1. Basic Application Circuit



**ABSOLUTE MAXIMUM RATINGS** (Note 1)

Parameter	Value	Parameter	Value
Input Supply Voltage	-0.3V to 6V	Junction Temperature (Note 2)	160°C
EN,FB Voltages	-0.3V to 6V	Operating Temperature Range	-40°C to 85°C
SW Voltage	-0.3V to 30V	Lead Temperature (Soldering,10s)	300°C
Power Dissipation	0.6W	Storage Temperature Range	-65°C to 150°C
Thermal Resistance $\theta_{JC}$	130°C/W	ESD HBM(Human Body Mode)	2kV
Thermal Resistance $\theta_{JA}$	250°C/W	ESD MM(Machine Mode)	200V

**ELECTRICAL CHARACTERISTICS (Note 3)**

 ( $V_{IN}=V_{EN}=3.7V$ ,  $T_A = 25^{\circ}C$ , unless otherwise noted.)

PARAMETER	CONDITIONS	MIN	TYP	MAX	UNIT
Operating Input Voltage		2.5		5.5	V
Under Voltage Lockout			2.2	2.45	V
Under Voltage Lockout Hysteresis			100		mV
Current (Shutdown)	$V_{EN} = 0V$		0.1	1	$\mu A$
Quiescent Current (PFM)	$V_{FB}=1.4V$ , No switch		40	60	$\mu A$
Quiescent Current (PWM)	$V_{FB}=1V$ , switch		0.6	1	mA
Switching Frequency			1.2		MHz
Maximum Duty Cycle	$V_{FB} = 0V$	90			%
EN Input High Voltage		1.5			V
EN Input Low Voltage				0.4	V
FB Voltage		1.225	1.25	1.275	V
FB Input Bias Current	$V_{FB} = 1.2V$	-50	-10		nA
SW On Resistance			0.5		$\Omega$
SW Current Limit	$V_{IN} = 4.2V$ , Duty cycle=50%		1.5		A
SW Leakage	$V_{SW}= 20V$			1	$\mu A$
Thermal Shutdown			155		$^{\circ}C$
Operating Input Voltage		2.5		5.5	V
Under Voltage Lockout			2.2	2.45	V

**Note 1:** Absolute Maximum Ratings are those values beyond which the life of a device may be impaired.

**Note 2:**  $T_J$  is calculated from the ambient temperature  $T_A$  and power dissipation  $P_D$  according to the following formula:  $T_J = T_A + (P_D) \times (250^{\circ}C/W)$ .

**Note 3:** 100% production test at  $25^{\circ}C$ . Specifications over the temperature range are guaranteed by design and characterization.

**TYPICAL PERFORMANCE CHARACTERISTICS**

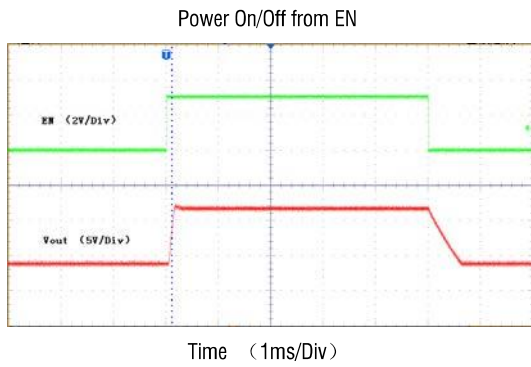
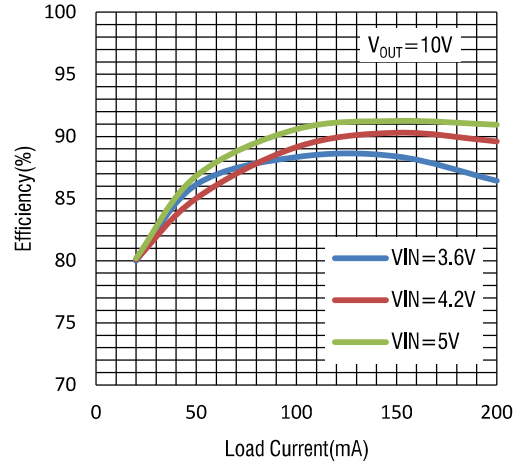
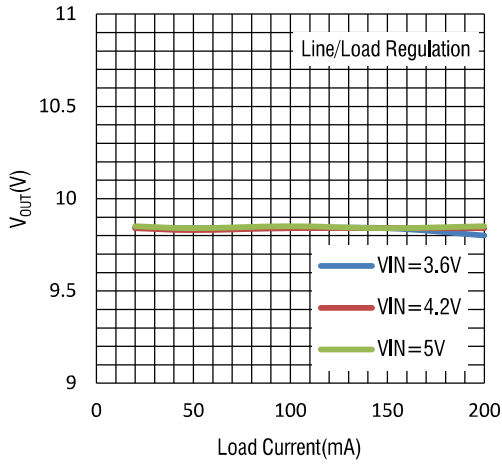

V<sub>IN</sub> = 5V, V<sub>OUT</sub> = 10V, I<sub>OUT</sub> = 50mA  
(CH1: V<sub>OUT</sub>(ripple) CH2: V<sub>SW</sub>)

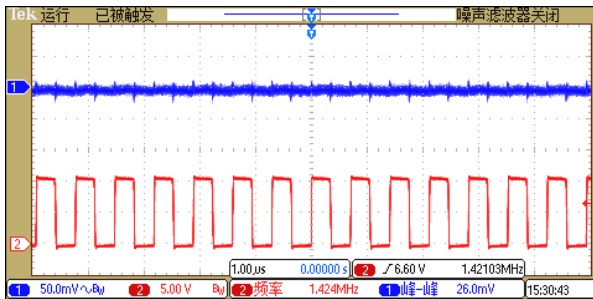

V<sub>IN</sub> = 5V, V<sub>OUT</sub> = 10V, I<sub>OUT</sub> = 200mA  
(CH1: V<sub>OUT</sub>(ripple) CH2: V<sub>SW</sub>)

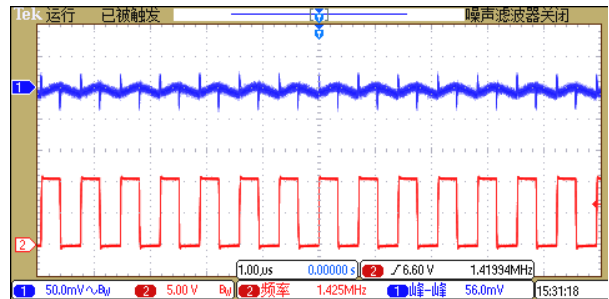

**FUNCTIONAL BLOCK DIAGRAM**

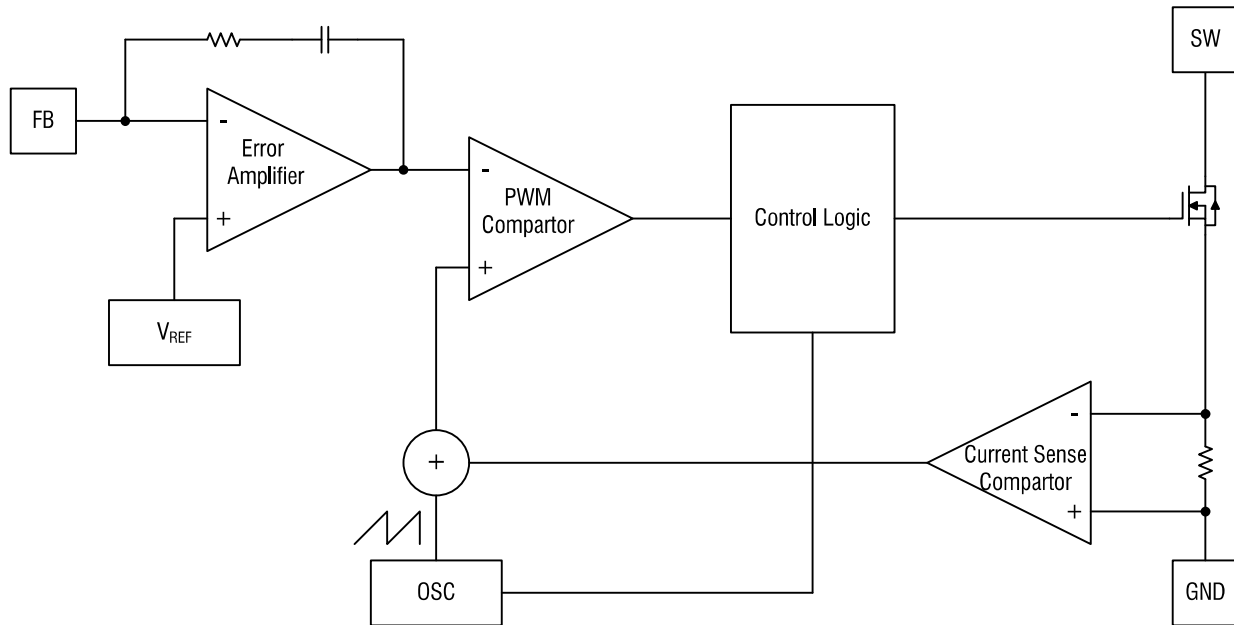

Figure 2. TPS61040DBVR-MS Block Diagram

**FUNCTIONAL DESCRIPTION**

The TPS61040DBVR-MS uses a fixed frequency, peak current mode boost regulator architecture to regulate voltage at the feedback pin. The operation of the TPS61040DBVR-MS can be understood by referring to the block diagram of Figure 2. At the start of each oscillator cycle the MOSFET is turned on through the control circuitry. To prevent sub-harmonic oscillations at duty cycles greater than 50 percent, a stabilizing ramp is added to the output of the current sense amplifier and the result is fed into the negative input of the PWM comparator. When this voltage equals the output voltage of the error amplifier the power MOSFET is turned off.

The voltage at the output of the error amplifier is an amplified version of the difference between the bandgap reference voltage and the feedback voltage. In this way the peak current level keeps the output in regulation. If the feedback voltage starts to drop, the output of the error amplifier increases. This results in more current to flow through the power MOSFET, thus increasing the power delivered to the output. The TPS61040DBVR-MS has internal soft start to limit the amount of input current at startup and to also limit the amount of overshoot on the output.

## APPLICATIONS INFORMATION

### Setting the Output Voltage

The internal reference  $V_{REF}$  is 1.25V.

The output voltage is divided by a resistor divider, R1 and R2 to the FB pin. The output voltage is given by

$$V_{OUT} = V_{REF} \times \left( 1 + \frac{R_1}{R_2} \right)$$

### Inductor Selection

The recommended value of inductor are 4.7 to 22H. Small size and better efficiency are the major concerns for portable device, such as TPS61040DBVR-MS used for mobile phone. The inductor should have low core loss at 1.2MHz and low DCR for better efficiency. To avoid inductor saturation current rating should be considered.

### Capacitor Selection

Input and output ceramic capacitors of 1 $\mu$ F are recommended for TPS61040DBVR-MS applications. For better voltage filtering, ceramic capacitors with low ESR are recommended. X5R and X7R types are suitable because of their wider voltage and temperature ranges.

### Diode Selection

Schottky diode is a good choice for TPS61040DBVR-MS because of its low forward voltage drop and fast reverse recovery. Using Schottky diode can get better efficiency. The highspeed rectification is also a good characteristic of Schottky diode for high switching frequency. Current rating of the diode must meet the root mean square of the peak current and output average current multiplication as following :

$$I_D(RMS) \approx \sqrt{I_{OUT} \times I_{PEAK}}$$

The diode's reverse breakdown voltage should be larger than the output voltage.

### Layout Consideration

For best performance of the TPS61040DBVR-MS, the following guidelines must be strictly followed.

- Input and Output capacitors should be placed close to the IC and connected to ground plane to reduce noise coupling.
- The GND should be connected to a strong ground plane for heat sinking and noise protection.
- Keep the main current traces as possible as short and wide.
- SW node of DC-DC converter is with high frequency voltage swing. It should be kept at a small area.
- Place the feedback components as close as possible to the IC and keep away from the noisy devices.

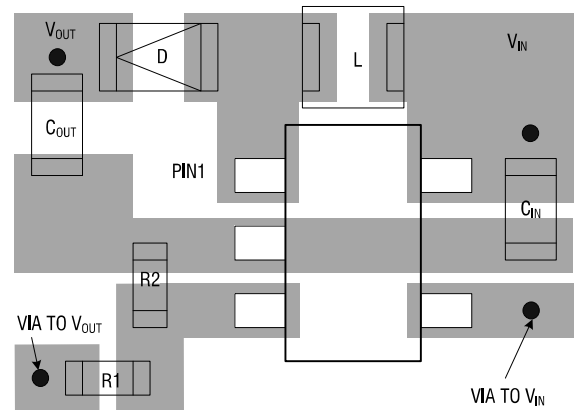
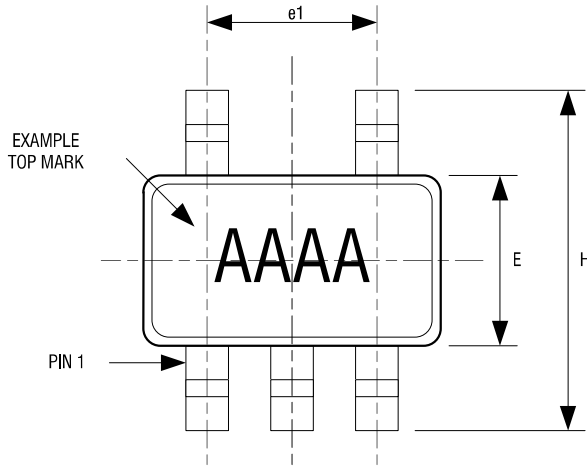

Figure 3. TPS61040DBVR-MS Suggested Layout

**PACKAGE DESCRIPTION**

**SOT-23-5**



TOP VIEW

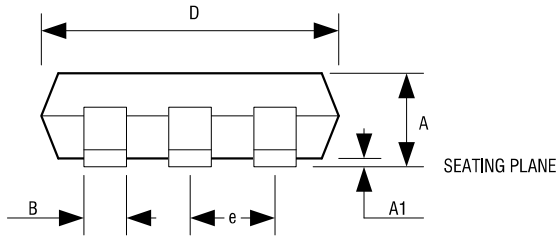

FRONT VIEW

5LD SOT-23 PACKAGE OUTLINE DIMENSIONS

Dimension	Min.	Max.
A	1.05	1.35
A1	0.04	.15
B	0.3	0.5
C	0.09	0.2
D	2.8	3.0
H	2.5	3.1
E	1.5	1.7
e	0.95 REF.	
e1	1.90 REF.	
L1	0.2	0.55
L	0.35	0.8
Q	0°	10°

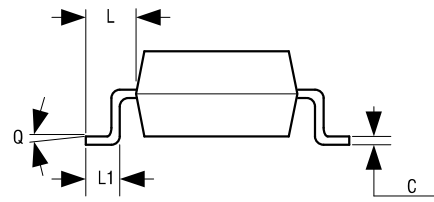

SIDE VIEW

**NOTE:**

1. DIMENSIONS ARE IN MILLIMETERS
2. DRAWING NOT TO SCALE
3. DIMENSIONS ARE INCLUSIVE OF PLATING
4. DIMENSIONS ARE EXCLUSIVE OF MOLD FLASH AND METAL BURR

## Attention

- Any and all MSKSEMI Semiconductor products described or contained herein do not have specifications that can handle applications that require extremely high levels of reliability, such as life-support systems, aircraft's control systems, or other applications whose failure can be reasonably expected to result in serious physical and/or material damage. Consult with your MSKSEMI Semiconductor representative nearest you before using any MSKSEMI Semiconductor products described or contained herein in such applications.
- MSKSEMI Semiconductor assumes no responsibility for equipment failures that result from using products at values that exceed, even momentarily, rated values (such as maximum ratings, operating condition ranges, or other parameters) listed in products specifications of any and all MSKSEMI Semiconductor products described or contained herein.
- Specifications of any and all MSKSEMI Semiconductor products described or contained herein stipulate the performance, characteristics, and functions of the described products in the independent state, and are not guarantees of the performance, characteristics, and functions of the described products as mounted in the customer's products or equipment. To verify symptoms and states that cannot be evaluated in an independent device, the customer should always evaluate and test devices mounted in the customer's products or equipment.
- MSKSEMI Semiconductor strives to supply high-quality high-reliability products. However, any and all semiconductor products fail with some probability. It is possible that these probabilistic failures could give rise to accidents or events that could endanger human lives, that could give rise to smoke or fire, or that could cause damage to other property. When designing equipment, adopt safety measures so that these kinds of accidents or events cannot occur. Such measures include but are not limited to protective circuits and error prevention circuits for safe design, redundant design, and structural design.
- In the event that any or all MSKSEMI Semiconductor products (including technical data, services) described or contained herein are controlled under any of applicable local export control laws and regulations, such products must not be exported without obtaining the export license from the authorities concerned in accordance with the above law.
- No part of this publication may be reproduced or transmitted in any form or by any means, electronic or mechanical, including photocopying and recording, or any information storage or retrieval system, or otherwise, without the prior written permission of MSKSEMI Semiconductor.
- Information (including circuit diagrams and circuit parameters) herein is for example only ; it is not guaranteed for volume production. MSKSEMI Semiconductor believes information herein is accurate and reliable, but no guarantees are made or implied regarding its use or any infringements of intellectual property rights or other rights of third parties.
- Any and all information described or contained herein are subject to change without notice due to product/technology improvement, etc. When designing equipment, refer to the "Delivery Specification" for the MSKSEMI Semiconductor product that you intend to use.