

MSKSEMI 美森科

SEMICONDUCTOR



ESD



TVS



TSS



MOV



GDT

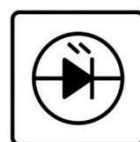

PLED

SN65LBC184DR-MS

产品手册

概述

SN65LBC184DR-MS 3V 至 5.5 V 供电, ±15kV 防静电, 慢速限制差分收发器, 提供完整 RS-485 兼容性, 用于半双工通信。每个部分包含一个 驱动器和一个接收器, 设计用于扩展共模范围(-7V 至 12V)的数据传输。SN65LBC184DR-MS 传数据速率高达 15Mbps。

SN65LBC184DR-MS 还具有增强的静电放电(ESD)保护 功能。使用 IEC61000-4-2 气隙放电, 所有发送器输出和接收器输入均保护为 ±15kV, 使用人体模型保护为 ±15kV, 使用 IEC61000-4-2 接触放电保护为 ±8kV。

驱动器短路电流有限。当驱动器输出通过热关断电路置于高阻抗状态时, 驱动器可防止过度功耗。接收器(Rx)输入具有“全故障 安全”设计, 可确保在 Rx 输入浮动、短路或 终止但未驱动的情况下具有逻辑高 Rx 输出。

两个部分都有上/下电模式, 无故障驱动器输出允许实时插入或从数据总线中取出收发器。CMOS 设计在不牺牲抗过载或 ESD 损坏的坚固性的情况下显著节省功耗。典型的 静态电流在工作时仅为 300uA, 在关机模式下为 1uA。



产品特点

- 高通讯速率, 3.3V 和 5V 供电, 15Mbps
- 高 ESD 防护能力
- 低功耗, 低至 1μA 电流, 关断模式
- -7V ~ +12V 共模输入电压范围
- 总线连接多达 256 节点
- 热关断保护功能
- 驱动过载保护功能
- 全故障保护 (开路、短路等)

应用范围

- 电力通讯
- 综合数字网络
- 工业控制局域网
- RS422 接口

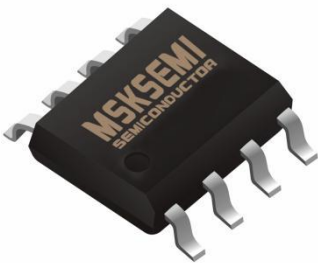
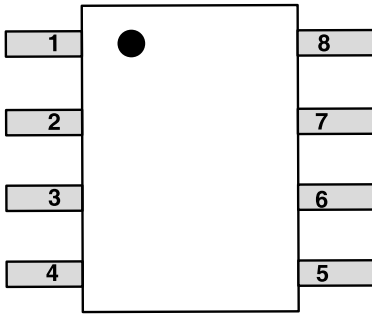
封装脚位信息

SOP-8	封装脚位图	管体标记
		

引脚功能描述

引脚		类型	描述
名称	序号		
RO	1	输出	反向输出
/RE	2	输入	反向输出使能
DE	3	输入	驱动使能
DI	4	输入	驱动输入
GND	5	电源	参考地
A	6	I/O	非反相接收器输入和非反相驱动器输出
B	7	I/O	反相接收器输入和反相驱动器输出
Vcc	8	Power	RS-485 收发器供电

订单信息

型号	工作温度	封装	包装
SN65LBC184DR-MS	-40°C ~ 125°C	SOP-8	2500PCS

功能框图

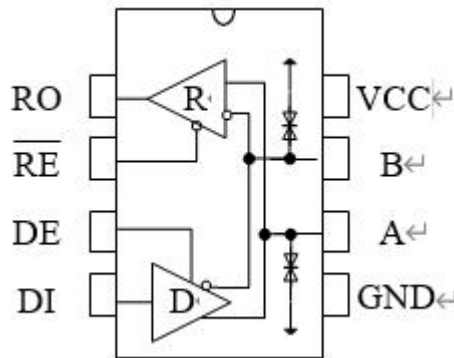

芯片功能框图

极限参数

超出绝对最大额定值可能会导致器件永久损坏，长时间工作在绝对最大额定值条件下可能会影响器件的可靠性。

名称	符号	Notes	最小	最大	单位
供电	Vcc		-0.3	7	V
控制输入电压	RE,DE		-0.3	Vcc+0.3	V
驱动输入电压	DI		-0.3	Vcc+0.3	V
驱动输出电压	A,B		-8	15	V
反向输入电压	A,B		-8	15	V
反向输出电压	RO		-0.3	Vcc+0.3	V
环境温度	Ta		-40	125	°C
储存温度	Tstg		-60	150	°C

静电保护

人体模型(HBM)测试按照EIA/JESD22-A114-B HBM

测试参数		数值	单位	
静电防护V _{ESD}	人体模型 (HBM)	A, B 端口至GND	±15	kV
		其它引脚	±8	kV
	器件模型 (CDM)	所有引脚	±2	kV

电参数

 (测试条件为Vcc = +3.3V to +5V, TA = T_{MIN} to T_{MAX}, 除另有说明, 环境温度+25°C.)

参数	符号	测试条件	最小	典型	最大	单位
供电						
供电电压	Vcc		3	5	5.5	V
供电电流	Icc	接收模式/RE=0;DE=0; Vcc=5V		240	650	uA
		发送E=1;DE=1;Vcc=5V		270	750	uA
		接收模式 E=0; DE=0; Vcc=3.3V		250	650	uA
		发送模式 RE=1;DE=1;Vcc=3.3V		280	750	uA
关断电流	Ishdn	/RE=VCC,DE=0,VCC=3.3V		0.2	10	uA
		/RE=VCC,DE=0,VCC=5V		0.2	10	uA
逻辑						
输入高逻辑电平	VIH	DE,DI,/RE	2.0			V
输入低逻辑电平	VIL	DE,DI,/RE			0.8	V
DI输入滞回电平	VHYS	-7V≤VCM≤12V	10	30		mV
接收						
三态电流	IOZR	0.4V<VO<2.4V			±1	uA
短路电流	IOSR	0V≤VO≤VCC	±8		±90	mA
输出高电压	VOH	V _A =2.8V, V _B =2.5V, IRO=8mA	Vcc-1.5			V
输出低电压	VOL	V _A =2.5V, V _B =2.8V, IRO=-8mA			0.4	V
输入阻抗	RIN	-7V≤VCM≤12V	96			kΩ
差分阈值电压	VTH		-200		-50	mV
输入滞回电压	ΔVTH	-7V≤VCM≤12V		25		mV
发送						
输出电压 (无负载)	VOD1		3		5.5	V
输出电压	VOD2	RL=54Ω,VCC=5V	1.5		VCC	V
电压幅值变化	ΔVOD	RL=54Ω			0.2	V
共模电压	VOC	RL=54Ω			3	V
共模电压变化	ΔVOC	RL=54Ω			0.3	V
短路电流	IOSD	短路到低-7-0V	-250			mA
		短路到高0-12V			250	

开关特性参数

 (V_{CC} = +3.3V to +5V, T_A = T_{MIN} to T_{MAX}, 除有其它说明, 典型在3.3VT和+5V, 环境温度+25°C.)

参数	符号	测试条件	最小	典型	最大	单位
发送						
最大传输速率	f _{MAX}			15000		kbps
差分输出延时	t _{DD}	R _L = 60Ω, Figure 3		20	40	ns
差分输出转换时间	t _{TD}	R _L = 60Ω, Figure 3		12	28	ns
传输输出延时, 由低 转高电平	t _{PLH}	R _L = 27Ω, Figure 4		20	40	ns
传输输出延时, 由高 转低电平	t _{PHL}	R _L = 27Ω, Figure 4		20	40	ns
t _{PLH} - t _{PHL} 发送传输延时 (Note2)	t _{PDS}	R _L = 27Ω, Figure 4		1	8	ns
发送输出使能和关断时间						
输出使能至逻辑 低电平	t _{PZL}	R _L = 110Ω, Figure 6			55	ns
输出使能至逻辑 高电平	t _{PZH}	R _L = 110Ω, Figure 5			55	ns
输出关断至逻辑 高电平	t _{PHZ}	R _L = 110Ω, Figure 5			85	ns
输出关断至逻辑 低	t _{PLZ}	R _L = 110Ω, Figure 6			85	ns
输出使能时间从关断至逻辑低	t _{PSL}	R _L = 110Ω, Figure 6		20	100	ns
输出使能时间从 关断至逻辑高	t _{PSH}	R _L = 110Ω, Figure 5		20	100	ns
接收						
关断时间	tSHDN		50		300	ns
低至高延迟时间	tRPLH	V _{ID} = 0 to 3.0V, C _L = 15pF, Figure 7		60		ns
高到低延迟时间	tRPHL	V _{ID} = 0 to 3.0V, C _L = 15pF, Figure 7		60		ns
t _{RPLH} - t _{RPHL} 延迟 时间	tRPDS	V _{ID} = 0 to 3.0V, C _L = 15pF, Figure 7		3	10	ns
输出使能时间至低电平	tPRZL	C _L = 15pF, Figure 8		100	300	ns
输出使能时间至高电平	tPRZH	C _L = 15pF, Figure 8		100	300	ns
输出关断时间至高电平	tPRHZ	C _L = 15pF, Figure 8		25	55	ns
输出关断时间至 低电平	tPRLZ	C _L = 15pF, Figure 8		25	55	ns
输出使能时间由关断时间至低 电平	tPRSL	C _L = 15pF, Figure 8		100	300	ns
输出使能时间由 关断时间至高 电 平	tPRSH	C _L = 15pF, Figure 8		100	300	ns

通讯功能表

表1: 发送

输入			输出		模式
RE	DE	DI	B	A	
X	1	1	0	1	正常
X	1	0	1	0	正常
0	0	X	高阻	高阻	正常 I
1	0	X	高阻	高阻	关断

表2: 接收

INPUTS			OUTPUTS	MODE
RE	DE	A, B	RO	
0	X	>-50mV	1	正常
0	X	<-200mV	0	正常
0	X	输入开路	1	正常 I
1	0	X	高阻	关断

测试电路和典型电路



图 3 差分输出延时和转换时间

图 1 发送 V_{OD} 和 V_{OC}

图 2 接收 V_{OH} 和 V_{OL}

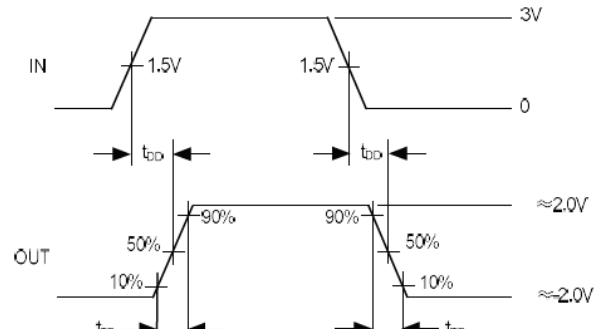
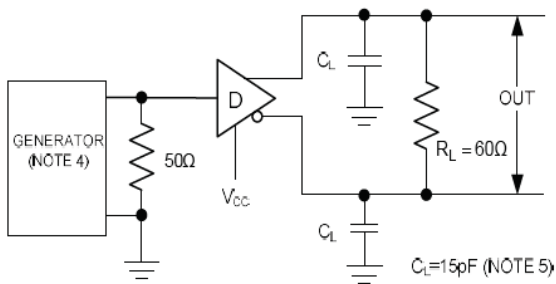
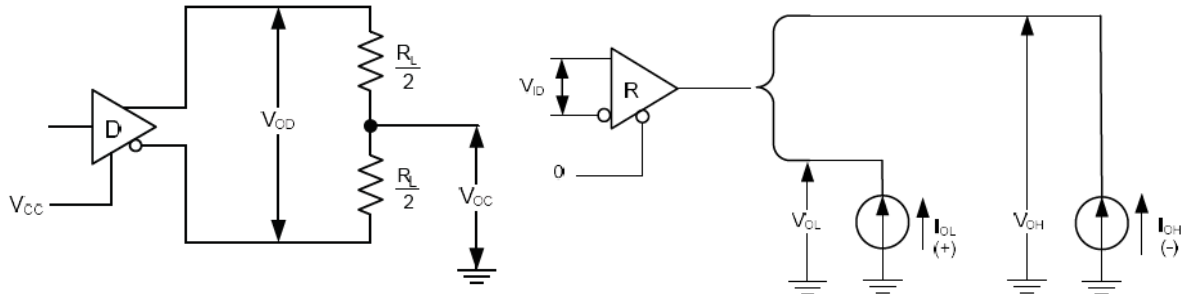

图 4 传输延时时间



图 5 使能和关断时间 (t_{pZH} , t_{pSH} , t_{pHZ})

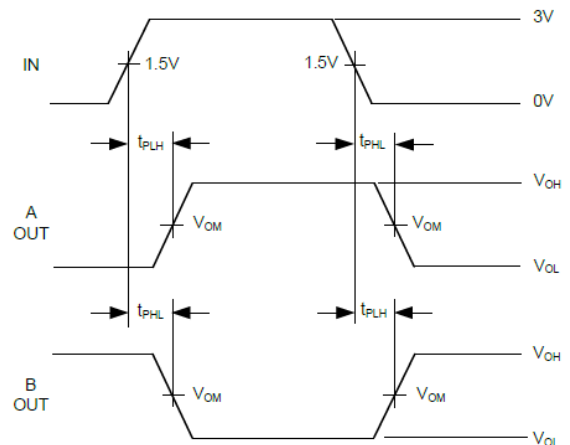
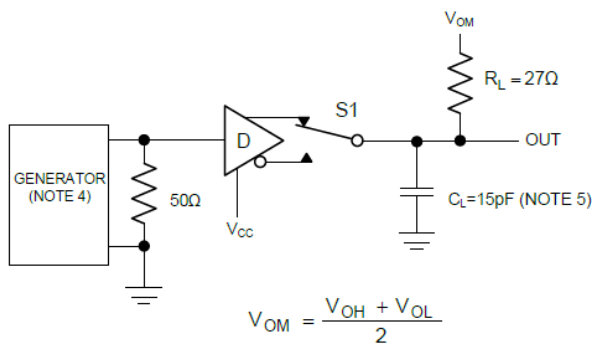

图 6 使能和关断时间 (t_{pZL} , t_{pSL} , t_{pLZ})

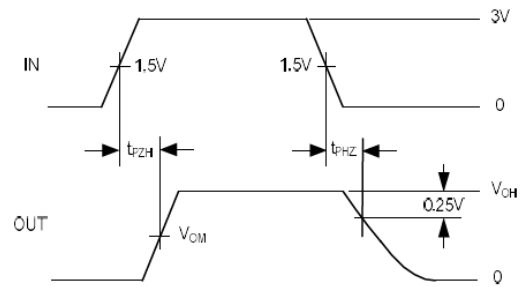
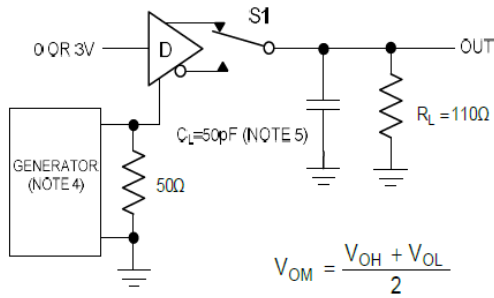

图 7 接收传输延时

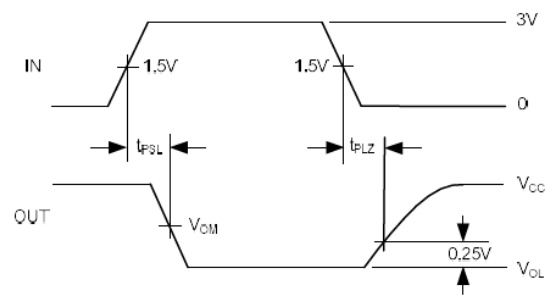
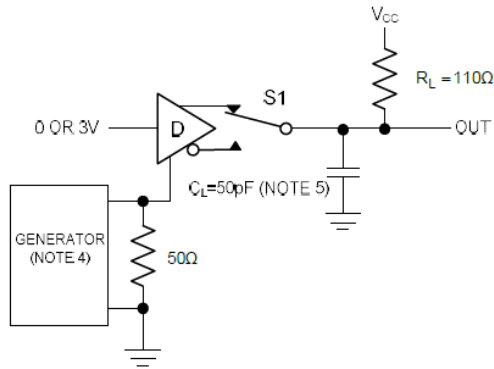

图 8 接收使用和关断时间

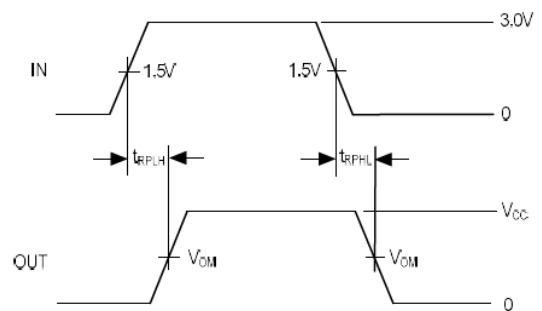
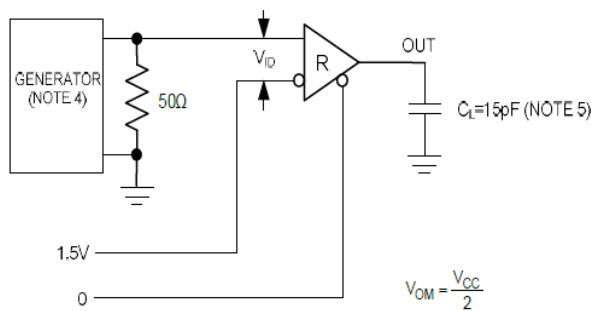

图 9 典型半双工 RS-485 组网应用

详细功能描述

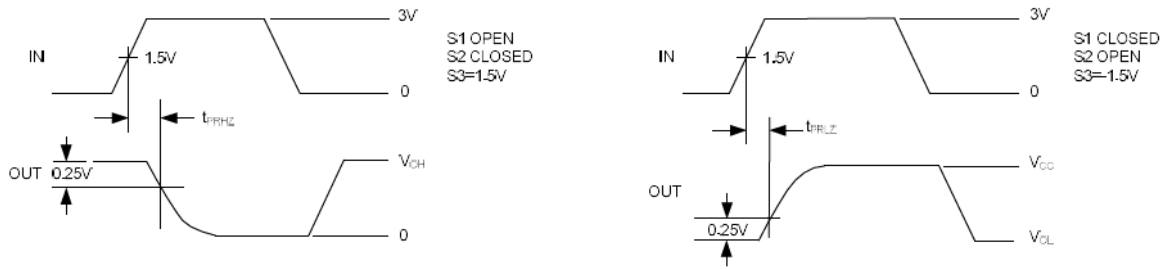
SN65LBC184DR-MS 系列是 RS-485 通信的低功耗收发器，可支持高达 15Mbps 的数据速率。所有部件均为半双工。包括驱动使能 (DE) 和接收器使能 (RE) 引脚。当关断时，驱动器和接收器输出为高阻抗。

● ESD保护

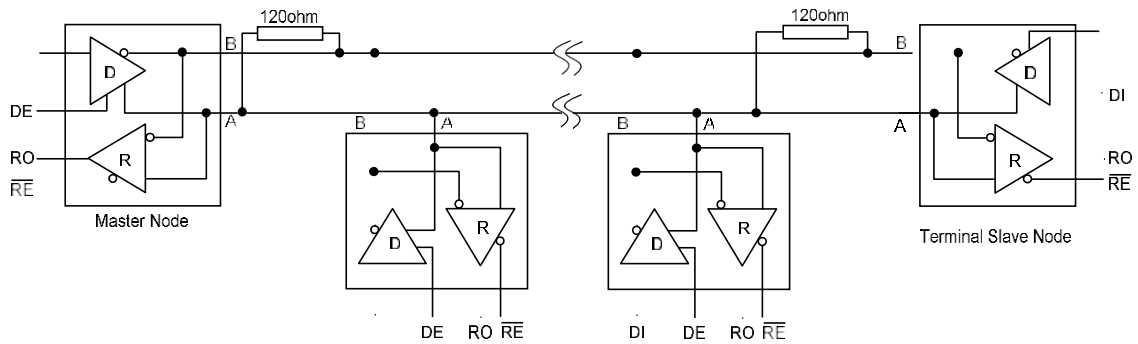
SN65LBC184DR-MS 支持 IEC61000-4-2 标准 $\pm 8\text{KV}$ 接触模式和 $\pm 15\text{kVHBM}$ 模式、 $\pm 15\text{KV}$ 空气模式 ESD 能力，SN65LBC184DR-MS AB 引脚特别容易受到 ESD 冲击，因为它们通常为产品的对外连接端口。人体简单地触摸端口或其它操作都可能会导致 ESD 问题的发生。

SN65LBC184DR-MS 本身已有良好的 ESD 能力；但是设备对外 AB 端口之间根据应用需求，增加额外的 ESD 保护器件来增强。

● 低功耗与关断模式

低功耗关机模式通过将 RE 调高和 DE 调低来启动。在关机时，设备通常只吸取 1 μA 的电源电流。RE 和 DE 可以同时驱动；当 RE 高、DE 低小于 50ns 时，保证部件不停机。如果输入在这个状态至少 300ns，保证零件进入停机状态。开关特性表中的使能时间 tPZH 和 tPZL 假设部件未处于低功耗关机状态。启用时间 tPSH 和 tPSL 假定部件已关闭。从低功耗关闭模式 (tPSH, tPSL) 中启用驱动程序和接收器所需的时间比从驱动程序/接收器禁用模式 (tPZH, tPZL) 中启用所需的时间更长。

● 总线支持256节点收发

标准 RS-485 接收器输入阻抗为 12k (一个单位负载)，标准驱动器可驱动多达 32 个单位负载。SN65LBC184DR-MS 收发器具有 1/8 单元负载接收器输入阻抗 (96k Ω)，允许在一条通信线路上并行连接多达 256 个收发器。这些设备和/或其他 RS-485 收发器的任何组合，总共 32 个单位负载或更少，都可以连接到线路上。

● 输出保护

输出保护机制可以防止因故障或母线争用而导致的输出电流过大和功率损耗。首先，在输出级上的折叠式电流限制，在整个共模电压范围内提供立即的短路保护。其次，一个热关闭电路，迫使驱动器输出到一个高阻抗状态，如果模具温度变得过高。

封装信息

SOP-8

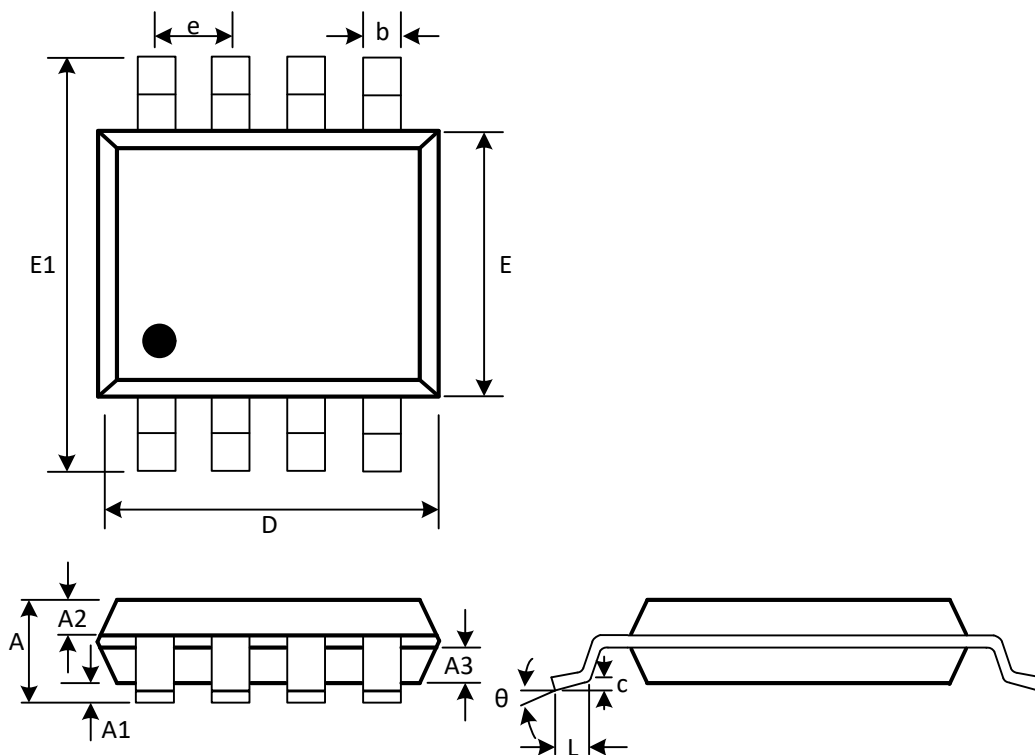

(Unit: mm)

Symbol	Min	Max
A	1.300	1.600
A1	0.050	0.200
A2	0.550	0.650
A3	0.550	0.650
b	0.356	0.456
c	0.203	0.233
D	4.800	5.000
e	1.270(BSC)	
E	3.800	4.000
E1	5.800	6.200
L	0.400	0.800
θ	0°	8°

Attention

- Any and all MSKSEMI Semiconductor products described or contained herein do not have specifications that can handle applications that require extremely high levels of reliability, such as life-support systems, aircraft's control systems, or other applications whose failure can be reasonably expected to result in serious physical and/or material damage. Consult with your MSKSEMI Semiconductor representative nearest you before using any MSKSEMI Semiconductor products described or contained herein in such applications.
- MSKSEMI Semiconductor assumes no responsibility for equipment failures that result from using products at values that exceed, even momentarily, rated values (such as maximum ratings, operating condition ranges, or other parameters) listed in products specifications of any and all MSKSEMI Semiconductor products described or contained herein.
- Specifications of any and all MSKSEMI Semiconductor products described or contained herein stipulate the performance, characteristics, and functions of the described products in the independent state, and are not guarantees of the performance, characteristics, and functions of the described products as mounted in the customer's products or equipment. To verify symptoms and states that cannot be evaluated in an independent device, the customer should always evaluate and test devices mounted in the customer's products or equipment.
- MSKSEMI Semiconductor strives to supply high-quality high-reliability products. However, any and all semiconductor products fail with some probability. It is possible that these probabilistic failures could give rise to accidents or events that could endanger human lives, that could give rise to smoke or fire, or that could cause damage to other property. When designing equipment, adopt safety measures so that these kinds of accidents or events cannot occur. Such measures include but are not limited to protective circuits and error prevention circuits for safe design, redundant design, and structural design.
- In the event that any or all MSKSEMI Semiconductor products (including technical data, services) described or contained herein are controlled under any of applicable local export control laws and regulations, such products must not be exported without obtaining the export license from the authorities concerned in accordance with the above law.
- No part of this publication may be reproduced or transmitted in any form or by any means, electronic or mechanical, including photocopying and recording, or any information storage or retrieval system, or otherwise, without the prior written permission of MSKSEMI Semiconductor.
- Information (including circuit diagrams and circuit parameters) herein is for example only ; it is not guaranteed for volume production. MSKSEMI Semiconductor believes information herein is accurate and reliable, but no guarantees are made or implied regarding its use or any infringement of intellectual property rights or other rights of third parties.
- Any and all information described or contained herein are subject to change without notice due to product/technology improvement, etc. When designing equipment, refer to the "Delivery Specification" for the MSKSEMI Semiconductor product that you intend to use.