

### Features

- ◆ Ultra low capacitance: 0.6pF typical I/O to GND
- ◆ Ultra low leakage: nA level
- ◆ Low operating voltage: 5.5V
- ◆ Uni-directional TVS Diode Array
- ◆ Low clamping voltage
- ◆ Complies with following standards:
  - IEC 61000-4-2 (ESD) immunity test
    - Air discharge: ±20kV
    - Contact discharge: ±15kV
  - IEC61000-4-5 (Lightning) 3.3A (8/20μs)
  - IEC61000-4-4 (EFT) 80A (5/50ns)
- ◆ ROHS Compliant

### Mechanical Characteristics

- ◆ Package: SOT23-6
- ◆ Lead Finish: Matte Tin
- ◆ Case Material: “Green” Molding Compound.
- ◆ UL Flammability Classification Rating 94V-0
- ◆ Moisture Sensitivity: Level 3 per J-STD-020

### Applications

- ◆ Glucose Meter
- ◆ Tablets
- ◆ GPS
- ◆ Portable Media Players

### Ordering Information

Part Number	Qty per Reel	Reel Size
TPD4E1U06DBVR	3000	7"

### Dimensions and Pin Configuration

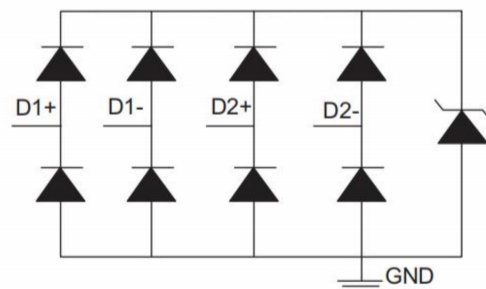
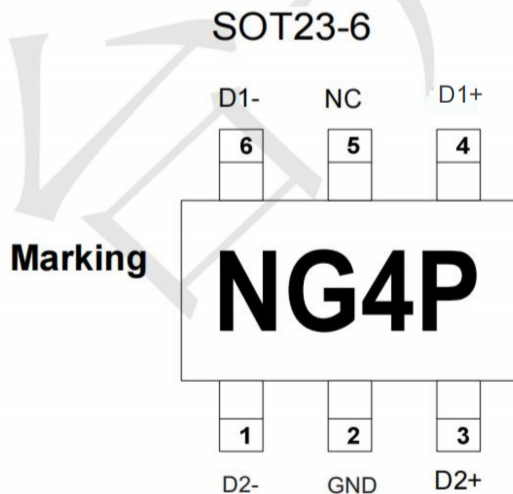

**Absolute Maximum Ratings** (T<sub>amb</sub>=25°C unless otherwise specified)

Parameter	Symbol	Value	Unit
Peak Pulse Power (8/20μs)	P <sub>pk</sub>	50	W
ESD per IEC61000-4-2 (Air)	V <sub>ESD</sub>	±20	kV
ESD per IEC61000-4-2 (Contact)		±15	
Operating Temperature Range	T <sub>J</sub>	-55 to +125	°C
Storage Temperature Range	T <sub>stg</sub>	-55 to +150	°C

**Electrical Characteristics** (T<sub>A</sub>=25°C unless otherwise specified)

Parameter	Symbol	Min	Typ	Max	Unit	Test Condition
Reverse Working Voltage	V <sub>RWM</sub>			5.5	V	
Breakdown Voltage	V <sub>BR</sub>	6.5		8.5	V	I <sub>T</sub> =1mA
Leakage Current	I <sub>Leak</sub>			10	nA	V <sub>RWM</sub> =2.5V
Dynamic resistance	R <sub>DYN</sub>		0.6		Ω	any I/O pin to GND
Clamping Voltage (I/O-GND)	V <sub>C</sub>			9	V	I <sub>PP</sub> =1A, T <sub>p</sub> =8/20 μs
Clamping Voltage (I/O-GND)	V <sub>C</sub>		13	14	V	I <sub>PP</sub> =3A, T <sub>p</sub> =8/20 μs
Junction Capacitance (I/O to GND)	C <sub>J</sub>		0.55	0.9	pF	V <sub>R</sub> =0V, f=1MHz,

### Typical Performance Characteristics ( $T_A=25^{\circ}\text{C}$ unless otherwise Specified)

**Fig1. 8/20 $\mu\text{s}$  Pulse Waveform**

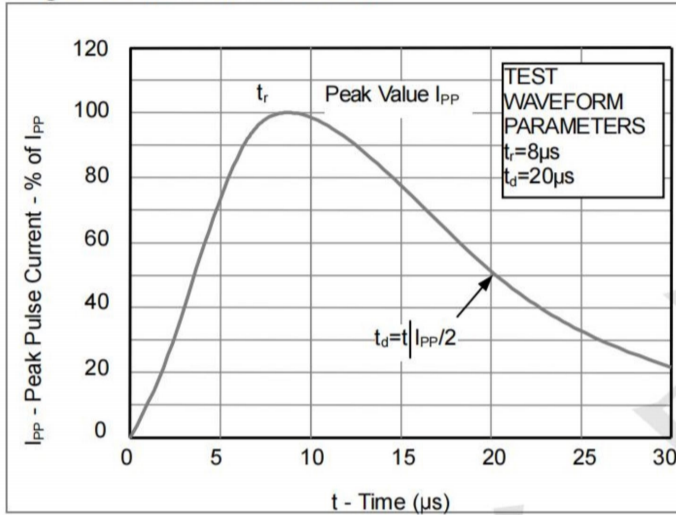

**Fig2. ESD Pulse Waveform (according to IEC 61000-4-2)**

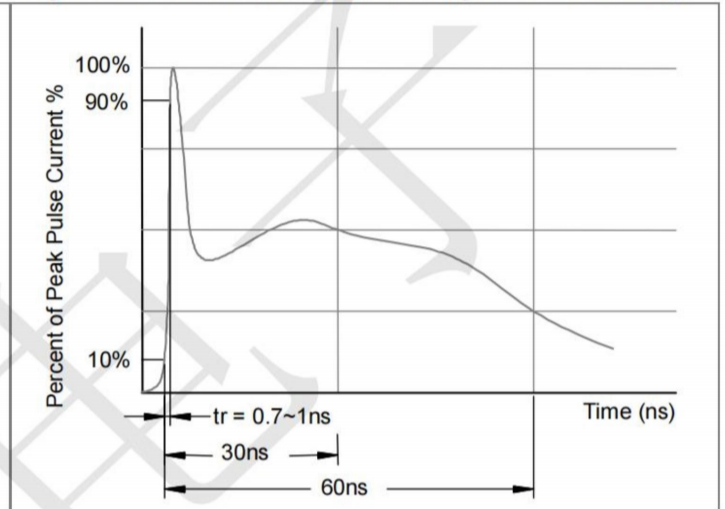

**Fig3. Power Derating Curve**

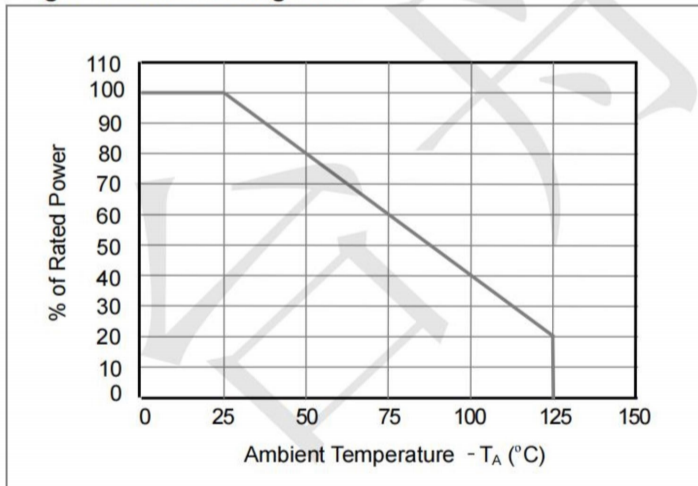

### Outline Drawing - SOT23-6

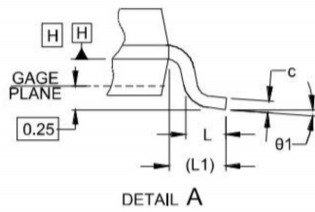
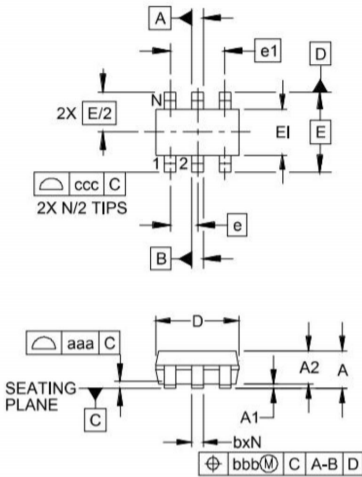

DIM	INCHES			MILLIMETERS		
	MIN	NOM	MAX	MIN	NOM	MAX
A	.035	-	.057	0.90	-	1.45
A1	.000	-	.006	0.00	-	0.15
A2	.035	.045	.051	.90	1.15	1.30
b	.010	-	.020	0.25	-	0.50
c	.003	-	.009	0.08	-	0.22
D	.110	.114	.118	2.80	2.90	3.00
E1	.060	.063	.069	1.50	1.60	1.75
E	.110 BSC			2.80 BSC		
e	.037 BSC			0.95 BSC		
e1	.075 BSC			1.90 BSC		
L	.012	.018	.024	0.30	0.45	0.60
L1	(.024)			(0.60)		
N	6			6		
theta1	0°	-	10°	0°	-	10°
aaa	.004			0.10		
bbb	.008			0.20		
ccc	.008			0.20		

### Land Pattern - SOT23-6

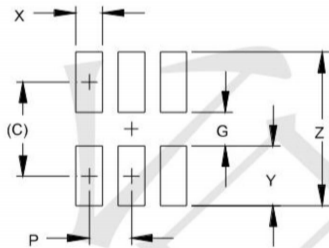

DIM	DIMENSIONS	
	INCHES	MILLIMETERS
C	(.098)	(2.50)
G	.055	1.40
P	.037	0.95
X	.024	0.60
Y	.043	1.10
Z	.141	3.60