

RoHS

REV.	ECN.#	DESCRIPTION	NAME	DATE
A0		NEW RELEASE	zhangxiuke	2025.01.15

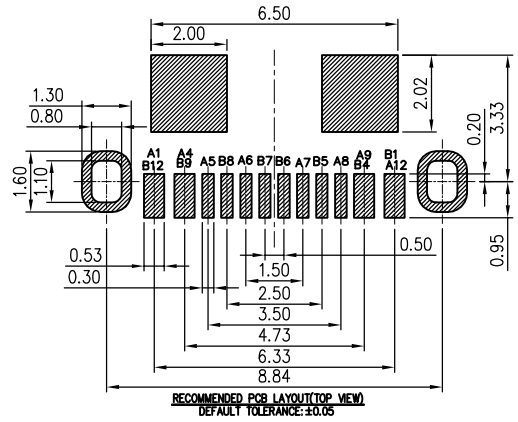
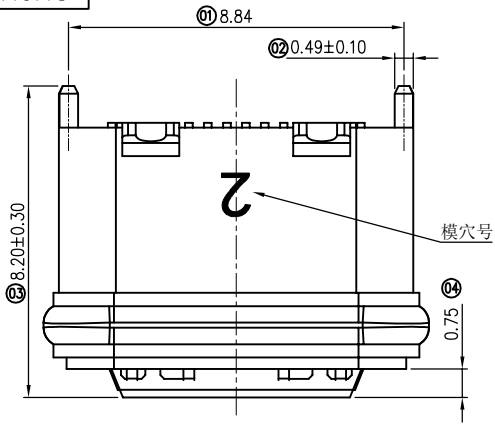

USB TYPE-C PIN ASSIGNMENTS

PIN NUMBER	SIGNAL NAME	PIN NUMBER	SIGNAL NAME
A1	GND	B12	GND
A4	VBUS	B9	VBUS
A5	CC1	B8	SBU2
A6	Dp1	B7	Dn2
A7	Dn1	B6	Dp2
A8	SBU1	B5	CC2
A9	VBUS	B4	VBUS
A12	GND	B1	GND

- NOTES:
- MATERIAL:
 - 1.1 HOUSING: PA10T UL94V-0; COLOR: BLACK
 - 1.2 CONTACT: C7025
 - 1.3 SHELL: ZINC ALLOY
 - 1.4 MID PLATE: SUS301
 - 1.5 O RING: SILICA GEL HCR 9150 UE COLOR:WHITE
 - 1.6 EPOXY:BLACK
 - FINISH:
 - 2.1 TERMINAL: 1u" PLATED ON CONTACT AREA; G/F PLATED ON SOLDER AREA; Ni 20u" MIN. UNDERPLATED OVERALL.
 - 2.2 SHELL: Ni 20u" MIN. PLATED OVERALL
 - 2.3 MID PLATE
 - ELECTRICAL SPECIFICATION:
 - 3.1 RATED CURRENT: VBUS AND GND PIN 3A; Other pin 0.25A
 - 3.2 CONTACT RESISTANCE: 40mΩ MAX(INITIAL). 50mΩ MAX (AFTER).
 - 3.3 INSULATION RESISTANCE: 100MΩ MIN.
 - 3.4 DIELECTRIC WITHSTANDING VOLTAGE: 100V AC R.M.S.
 - MACHINERY SPECIFICATION:
 - 4.1 MATING FORCE: 5N~20N. UNMATING FORCE: 8N~20N. (AFTER TEST:6N~20N).
 - 4.2 DURABILITY: 10000 CYCLES MIN.
 - ENVIRONMENTAL SPECIFICATION:
 - 5.1 OPERATING CONDITION: TEMPERATURE-25°C~+85°C; HUMIDITY 80% R.H MAX
 - 5.2 SALT SPRAY: 24H
 - SOLDER ABILITY: 245±5°C, 5±0.5s
 - IR REFLOW: THE PEAK TEMPERATURE ON THE BOARD SHALL BE MAINTAINED FOR 10 SECONDS AT 260°C.
 - WATER PROOFNESS: THIS PRODUCT IS BASED ON IPX7.

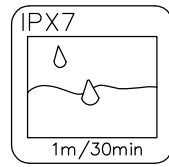
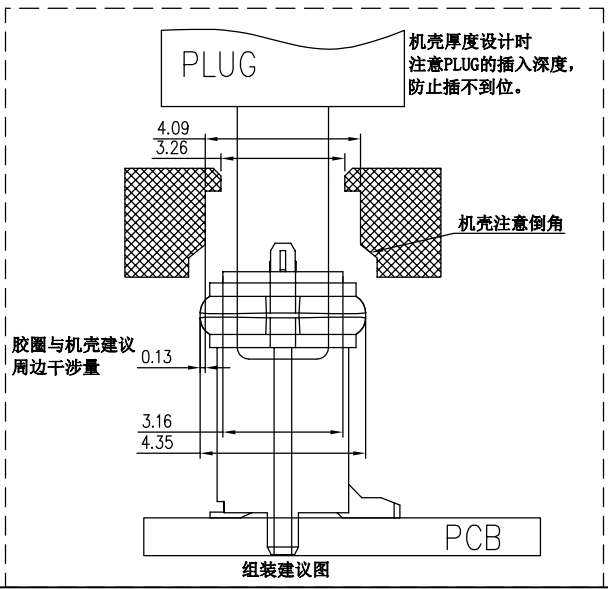
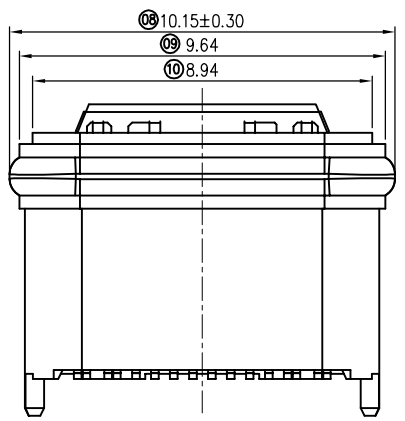
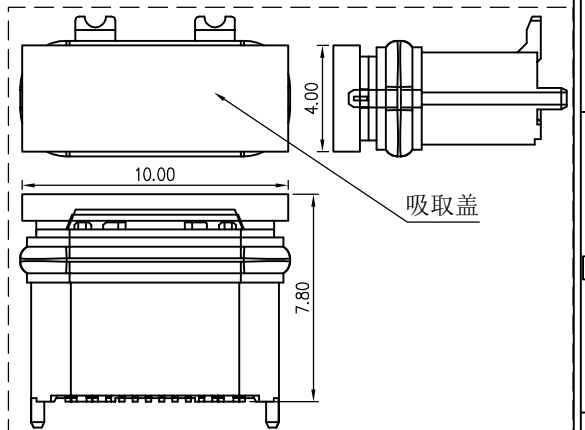
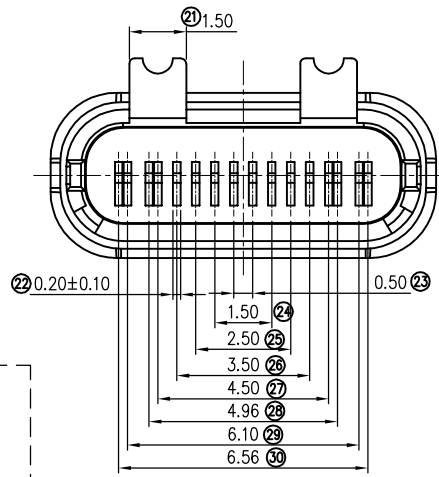
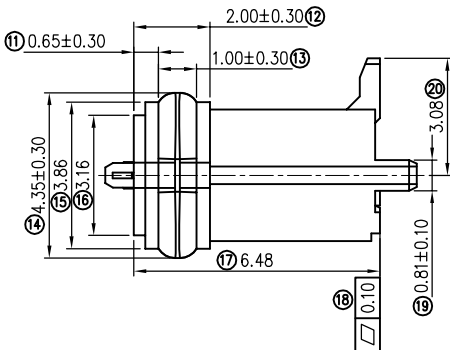
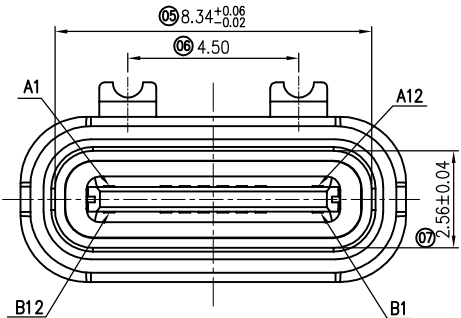

MILLIMETERS	INCH
X.* ±2*	X.* ±2*
X ±0.30	.X ±0.012
XX ±0.20	.XX ±0.008
XXX ±0.10	.XXX ±0.004

THESE DRAWINGS AND SPECIFICATIONS ARE THE PROPERTY OF DongGuan JinBilai Metal Plastic Technology Co.,Ltd
 COPIED OR USED IN ANY MANNER WITHOUT THE PRIOR WRITTEN CONSENT OF DongGuan JinBilai Metal Plastic Technology Co.,Ltd

JBL 东莞市金比莱五金塑胶科技有限公司
 DONGGUAN JBL TECH CO., LTD

TITLE	USB TYPE C 16PIN 立式防水母座	DR	
PART NO.	1043112752	CHKD	
PRO J.	PAGE 1/2 UNITS mm	APPD	
SIZE	A4 SCALE 1:1 DIS NO.		

RoHS

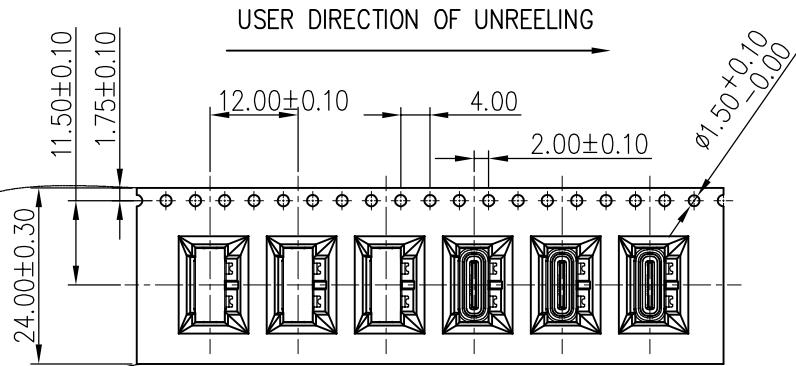

COVER TAPE PEELING ANGLE: 165°~180°
PEELING FORCE: 20~130g
CARRIER TAPE

USER DIRECTION OF UNREELING

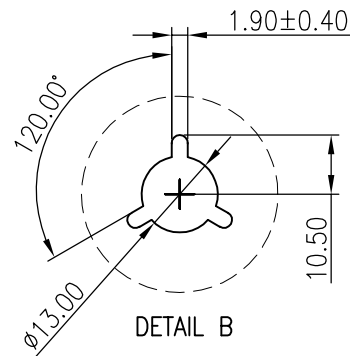
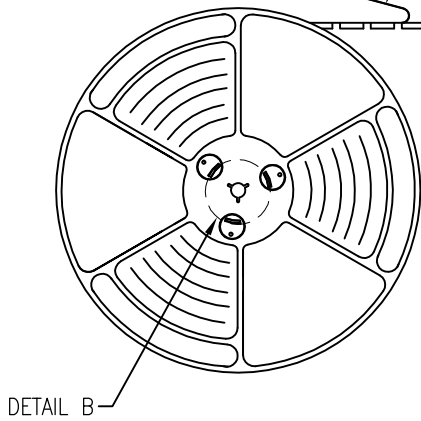

NOTES

1. NUMBER OF CONNECTORS: 600PCS/REEL
2. LEAD TAPE LENGTH

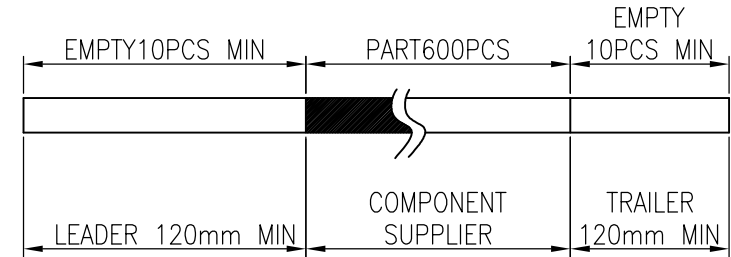

3. QUANTITY: 6000PCS/CARTON

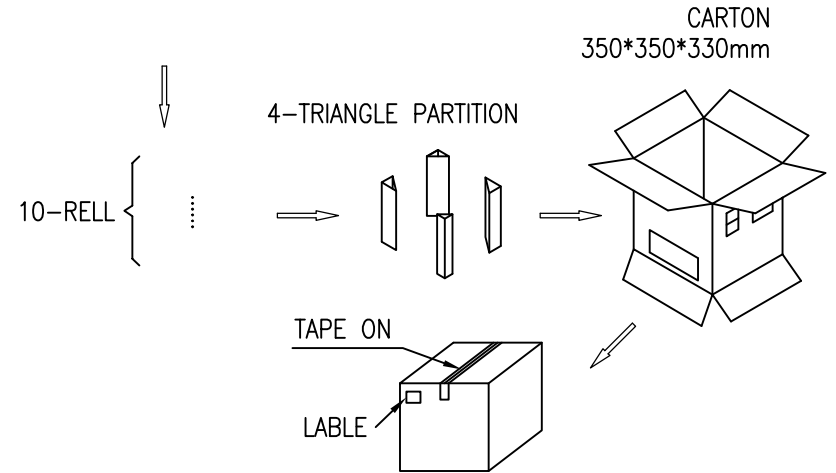

MILLIMETERS	INCH	东莞市金比莱五金塑胶科技有限公司 DONGGUAN JBL TECH CO., LTD			
X.* ±2*	X.* ±2*	TITLE	USB TYPE C 16PIN 立式 防水母座		DR
X ±0.30	.X ±0.012		PART NO. 1043112752		CHKD
XX ±0.20	.XX ±0.008	PRO J.	PAGE 2/2	UNITS mm	APPD
XXX ±0.10	.XXX ±0.004	SIZE	A4	SCALE 1:1	DIS NO.
THESE DRAWINGS AND SPECIFICATIONS ARE THE PROPERTY OF DongGuan JinBiLai Metal Plastic Technology Co.,Ltd COPIED OR USED IN ANY MANNER WITHOUT THE PRIOR WRITTEN CONSENT OF DongGuan JinBiLai Metal Plastic Technology Co.,Ltd					