

RoHS

REV.	ECN.#	DESCRIPTION	NAME	DATE
A0		NEW RELEASE	XieYun	2023.04.12

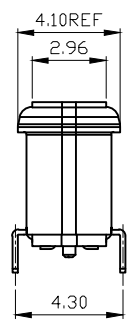
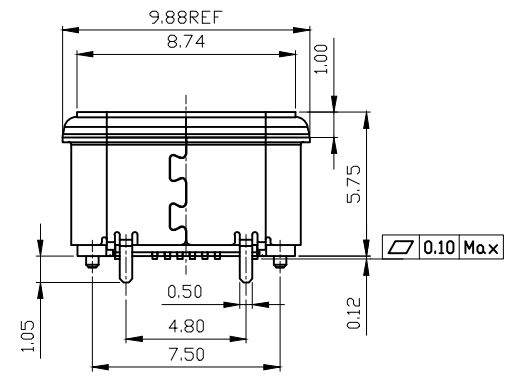
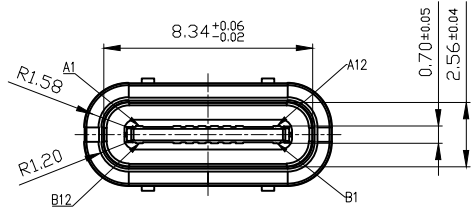

机壳面板

建议密封方式



密封圈

PCB板

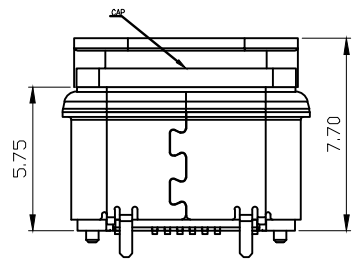
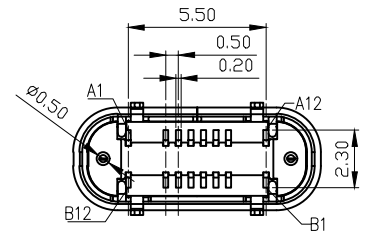
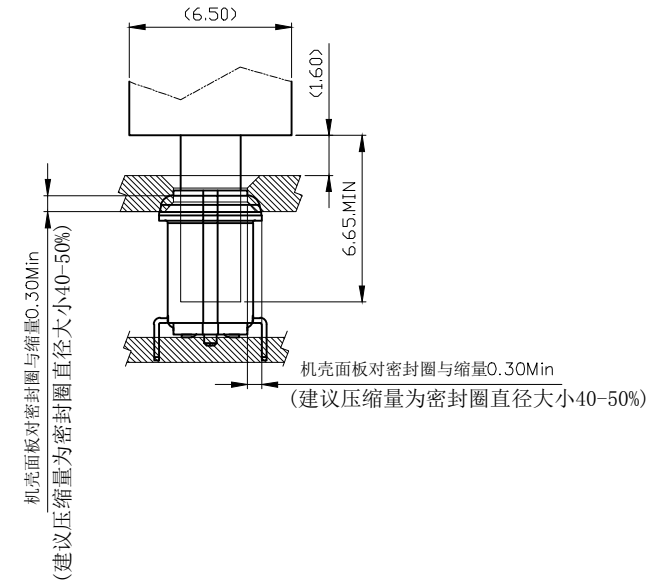

MILLIMETERS	INCH	东莞市金比莱五金塑胶科技有限公司 DongGuan JinBiLai Metal Plastic Technology Co.,Ltd			
X.' ±2'	X.' ±2'	TITLE	TYPE C 16PIN立式SMT防水母座 高H=5.75MM IPX6级	DR	
.X ±0.30	.X ±0.012	PART NO.	104319312	CHKD	
.XX ±0.20	.XX ±0.008	PRO J.	PAGE 1/3 UNITS mm	APPD	
.XXX ±0.10	.XXX ±0.004	SIZE	A4 SCALE 1:1 DIS NO.		
THESE DRAWINGS AND SPECIFICATIONS ARE THE PROPERTY OF DongGuan JinBiLai Metal Plastic Technology Co.,Ltd COPIED OR USED IN ANY MANNER WITHOUT THE PRIOR WRITTEN CONSENT OF DongGuan JinBiLai Metal Plastic Technology Co.,Ltd					

RoHS

REV.	ECN.#	DESCRIPTION	NAME	DATE
		NEW RELEASE	XieYun	2023.04.12

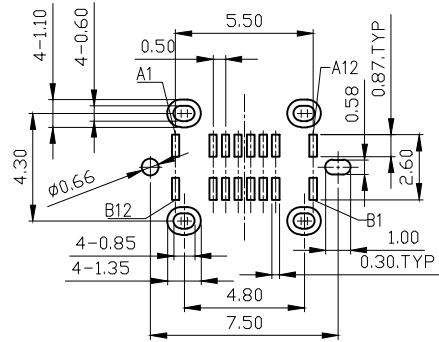
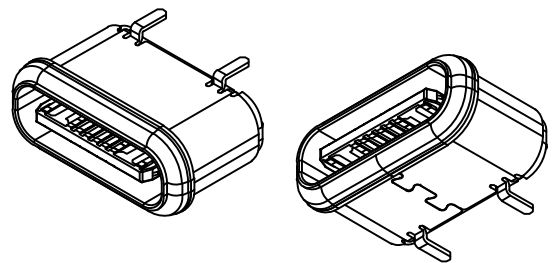

PCB LAYOUT ±0.05

NOTES:

1. MATERIAL:
 - 1.1 HOUSING: THERMAL PLASTIC; COLOR: BLACK
 - 1.2 INSULATION JACKET: THERMAL PLASTIC, Black, UL94V-0
 - 1.3 CONTACT: COPPER ALLOY
 - 1.4 MID PLATE: STAINLESS STEEL
 - 1.5 SHELL: STAINLESS STEEL
 - 1.6 O-RING: ACRYLATE
2. FINISH:
 - 2.1 TERMINAL: G/F PLATED ON CONTACT AREA;
G/F PLATED ON SOLDER AREA;
Ni 50u" MIN. UNDERPLATED OVERALL
 - 2.2 SHELL: Ni 30u" MIN. PLATED OVERALL
 - 2.3 Mid-Plate: CLEAR ONLY
3. ELECTRICAL SPECIFICATION:
 - 3.1 CURRENT RATING: 5A For Pin(A4,A9,B4,B9)
1.25A For Pin(B5)
0.25A For Others Pin
 - 3.2 CONTACT RESISTANCE: 50mΩ MAX.
 - 3.3 INSULATION RESISTANCE: 100MΩ MIN
 - 3.4 DIELECTRIC WITHSTANDING VOLTAGE: 100V AC
4. MACHINERY SPECIFICATION:
 - 4.1 MATING FORCE: 5-20N
UNMATING FORCE: 8-20N AFTER THE TEST 6-20N
 - 4.2 DURABILITY: 10000 CYCLES MIN.
5. ENVIRONMENTAL SPECIFICATION
 - 5.1 OPERATING CONDITION: TEMPERATURE -30°C~+85°C;
HUMIDITY 80% R.H MAX
 - 5.2 SALT SPRAY: 24H
6. SOLDER ABILITY: 245±5°C, 5±0.5s
7. IR REFLOW: THE PEAK TEMPERATURE ON THE BOARD SHALL BE MAINTAINED FOR 10 SECONDS AT 260°C.

A1	GND	B12	GND
A4	VBUS	B9	VBUS
A5	CC1	B8	SBU2
A6	D+	B7	D-
A7	D-	B6	D+
A8	SBU1	B5	CC2
A9	VBUS	B4	VBUS
A12	GND	B1	GND
PIN	SIGNAL NAME	PIN	SIGNAL NAME

MILLIMETERS	INCH	东莞市金比莱五金塑胶科技有限公司 DongGuan JinBiLai Metal Plastic Technology Co.,Ltd			
X.' ±2'	X.' ±2'		TYPE C 16PIN 立式SMT防水母座 高H=5.75MM IPX6级		DR
.X ±0.30	.X ±0.012		TITLE		
.XX ±0.20	.XX ±0.008		PART NO.	104319312	CHKD
.XXX ±0.10	.XXX ±0.004		PRO J.	PAGE 2/3 UNITS mm	APPD
THESE DRAWINGS AND SPECIFICATIONS ARE THE PROPERTY OF DongGuan JinBiLai Metal Plastic Technology Co.,Ltd COPIED OR USED IN ANY MANNER WITHOUT THE PRIOR WRITTEN CONSENT OF DongGuan JinBiLai Metal Plastic Technology Co.,Ltd		SIZE	A4	SCALE 1:1	DIS NO.