

1. DESCRIPTION

The XLM2575 series of regulators are monolithic integrated circuits ideally suited for easy and convenient design of a step-down switching regulator (buck converter). All circuits of this series are capable of driving a 1.0 A load with excellent line and load regulation. These devices are available in fixed output voltages of 3.3 V, 5.0 V, 12 V, and an adjustable output version.

These regulators were designed to minimize the number of external components to simplify the power supply design. Standard series of inductors optimized for use with the XLM2575 are offered by several different inductor manufacturers.

Since the XLM2575 converter is a switch-mode power supply, its efficiency is significantly higher in comparison with popular three-terminal linear regulators, especially with higher input voltages. In many cases, the power dissipated by the XLM2575 regulator is so low, that no heatsink is required or its size could be reduced dramatically.

The XLM2575 features include a guaranteed $\pm 4\%$ tolerance on output voltage within specified input voltages and output load conditions, and $\pm 10\%$ on the oscillator frequency ($\pm 2\%$ over 0°C to 85°C). External shutdown is included, featuring 80 A typical standby current. The output switch includes cycle-by-cycle current limiting, as well as thermal shutdown for full protection under fault conditions.

2. FEATURES

- 3.3 V, 5.0 V, 12 V, and Adjustable Output Versions
- Adjustable Version Output Voltage Range of 1.23 V to 37 V $\pm 4\%$ Maximum Over Line and Load Conditions
- Guaranteed 1.0 A Output Current
- Wide Input Voltage Range: 4.75 V to 40 V
- Requires Only 4 External Components
- 52 kHz Fixed Frequency Internal Oscillator
- TTL Shutdown Capability, Low Power Standby Mode
- High Efficiency
- Uses Readily Available Standard Inductors
- Thermal Shutdown and Current Limit Protection
- Pb-Free Packages are Available*

3. FEATURES

- Simple and High-Efficiency Step-Down (Buck) Regulators
- Efficient Pre-Regulator for Linear Regulators
- On-Card Switching Regulators
- Positive to Negative Converters (Buck-Boost)
- Negative Step-Up Converters
- Power Supply for Battery Chargers

4. TYPICAL APPLICATIONS (Fixed Output Voltage Versions)

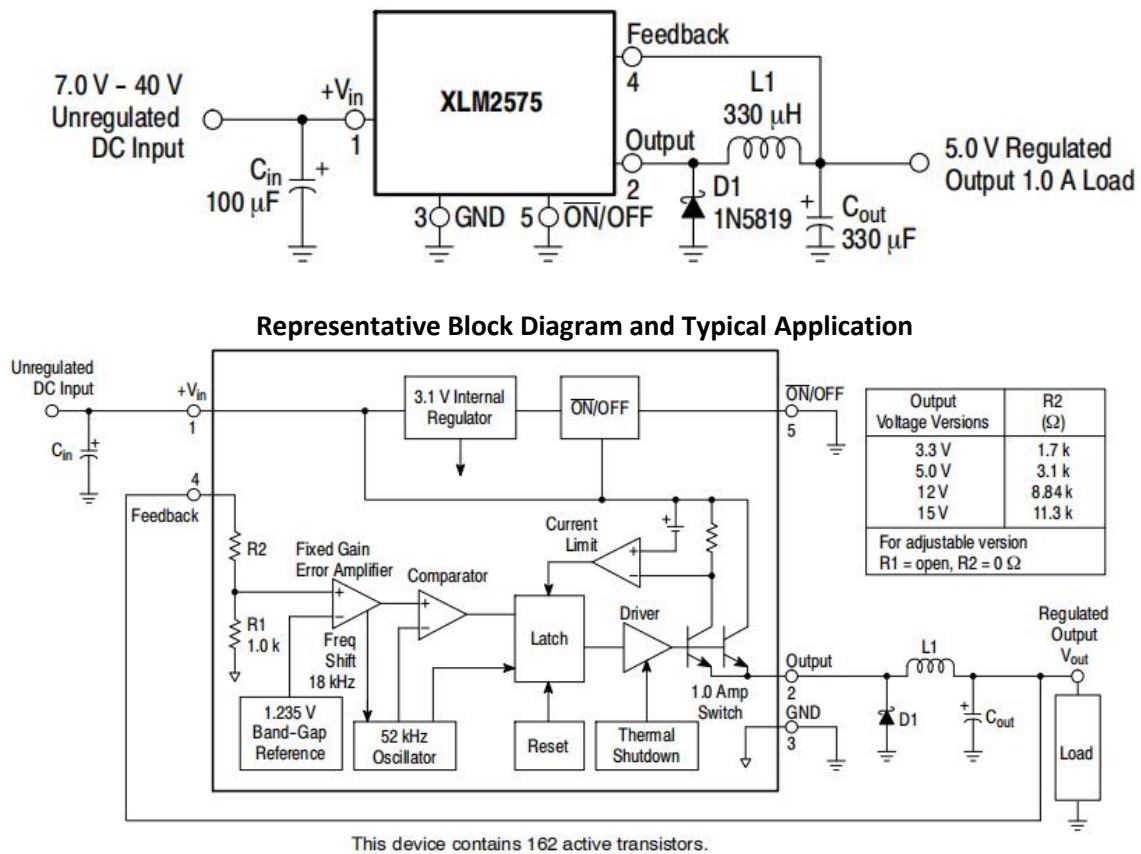

Figure 1. Block Diagram and Typical Application

5. ABSOLUTE MAXIMUM RATINGS (Absolute Maximum Ratings indicate limits beyond which damage to the device may occur.)

Rating	Symbol	Value	Unit
Maximum Supply Voltage	V_{in}	45	V
ON/OFF Pin Input Voltage	-	$-0.3\text{ V} \leq V \leq +V_{in}$	V
Output Voltage to Ground (Steady-State)	-	-1.0	V
Case TO-263	P_D	Internally Limited	W
Thermal Resistance, Junction-to-Ambient (Figure 34)	$R_{\theta JA}$	70	$^{\circ}\text{C}/\text{W}$
Thermal Resistance, Junction-to-Case	$R_{\theta JC}$	5.0	$^{\circ}\text{C}/\text{W}$
Storage Temperature Range	T_{stg}	-65 to +150	$^{\circ}\text{C}$
Minimum ESD Rating (Human Body Model: C = 100 pF, R = 1.5 k Ω)	-	2.0	kV
Lead Temperature (Soldering, 10 s)	-	260	$^{\circ}\text{C}$
Maximum Junction Temperature	T_J	150	$^{\circ}\text{C}$

Stresses exceeding Maximum Ratings may damage the device. Maximum Ratings are stress ratings only. Functional operation above the Recommended Operating Conditions is not implied. Extended exposure to stresses above the Recommended Operating Conditions may affect device reliability

6. OPERATING RATINGS (Operating Ratings indicate conditions for which the device is intended to be functional, but do not guarantee specific performance limits. For guaranteed specifications and test conditions, see the Electrical Characteristics.)

Rating	Symbol	Value	Unit
Operating Junction Temperature Range	T_J	-40 to +125	°C
Supply Voltage	V_{in}	40	V

7. SYSTEM PARAMETERS ([Note 1] Test Circuit Figure 14)

7.1. ELECTRICAL CHARACTERISTICS (Unless otherwise specified, $V_{in} = 12\text{ V}$ for the 3.3 V, 5.0 V, and Adjustable version, $V_{in} = 25\text{ V}$ for the 12 V version. $I_{Load} = 200\text{ mA}$. For typical values $T_J = 25^\circ\text{C}$, for min/max values T_J is the operating junction temperature range that applies [Note 2], unless otherwise noted.)

Characteristics	Symbol	Min	Typ	Max	Unit
XLM2575-3.3 (Note 1 Test Circuit Figure 14)					
Output Voltage ($V_{in} = 12\text{ V}$, $I_{Load} = 0.2\text{ A}$, $T_J = 25^\circ\text{C}$)	V_{out}	3.234	3.3	3.366	V
Output Voltage ($4.75\text{ V} \leq V_{in} \leq 40\text{ V}$, $0.2\text{ A} \leq I_{Load} \leq 1.0\text{ A}$) $T_J = 25^\circ\text{C}$ $T_J = -40\text{ to }+125^\circ\text{C}$	V_{out}	3.168 3.135	3.3 -	3.432 3.465	V
Efficiency ($V_{in} = 12\text{ V}$, $I_{Load} = 1.0\text{ A}$)	η	-	75	-	%
XLM2575-5 ([Note 1] Test Circuit Figure 14)					
Output Voltage ($V_{in} = 12\text{ V}$, $I_{Load} = 0.2\text{ A}$, $T_J = 25^\circ\text{C}$)	V_{out}	4.9	5.0	5.1	V
Output Voltage ($8.0\text{ V} \leq V_{in} \leq 40\text{ V}$, $0.2\text{ A} \leq I_{Load} \leq 1.0\text{ A}$) $T_J = 25^\circ\text{C}$ $T_J = -40\text{ to }+125^\circ\text{C}$	V_{out}	4.8 4.75	5.0 -	5.2 5.25	V
Efficiency ($V_{in} = 12\text{ V}$, $I_{Load} = 1.0\text{ A}$)	η	-	77	-	%
XLM2575-12 (Note 1 Test Circuit Figure 14)					
Output Voltage ($V_{in} = 25\text{ V}$, $I_{Load} = 0.2\text{ A}$, $T_J = 25^\circ\text{C}$)	V_{out}	11.76	12	12.24	V
Output Voltage ($15\text{ V} \leq V_{in} \leq 40\text{ V}$, $0.2\text{ A} \leq I_{Load} \leq 1.0\text{ A}$) $T_J = 25^\circ\text{C}$ $T_J = -40\text{ to }+125^\circ\text{C}$	V_{out}	11.52 11.4	12 -	12.48 12.6	V
Efficiency ($V_{in} = 15\text{ V}$, $I_{Load} = 1.0\text{ A}$)	η	-	88	-	%
XLM2575 ADJUSTABLE VERSION (Note 1 Test Circuit Figure 14)					
Feedback Voltage ($V_{in} = 12\text{ V}$, $I_{Load} = 0.2\text{ A}$, $V_{out} = 5.0\text{ V}$, $T_J = 25^\circ\text{C}$)	V_{FB}	1.217	1.23	1.243	V
Feedback Voltage ($8.0\text{ V} \leq V_{in} \leq 40\text{ V}$, $0.2\text{ A} \leq I_{Load} \leq 1.0\text{ A}$, $V_{out} = 5.0\text{ V}$) $T_J = 25^\circ\text{C}$ $T_J = -40\text{ to }+125^\circ\text{C}$	V_{FB}	1.193 1.18	1.23 -	1.267 1.28	V
Efficiency ($V_{in} = 12\text{ V}$, $I_{Load} = 1.0\text{ A}$, $V_{out} = 5.0\text{ V}$)	η	-	77	-	%

- External components such as the catch diode, inductor, input and output capacitors can affect switching regulator system performance. When the XLM2575 is used as shown in the Figure 14 test circuit, system performance will be as shown in system parameters section.
- Tested junction temperature range for the XLM2575 : $T_{low} = -40^\circ\text{C}$ $T_{high} = +125^\circ\text{C}$

8. DEVICE PARAMETERS

8.1. ELECTRICAL CHARACTERISTICS (Unless otherwise specified, $V_{in} = 12\text{ V}$ for the 3.3 V, 5.0 V, and Adjustable version, $V_{in} = 25\text{ V}$ for the 12 V version. $I_{Load} = 200\text{ mA}$. For typical values $T_J = 25^\circ\text{C}$, for min/max values T_J is the operating junction temperature range that applies [Note 2], unless otherwise noted.)

Characteristics	Symbol	Min	Typ	Max	Unit
ALL OUTPUT VOLTAGE VERSIONS					
Feedback Bias Current ($V_{out} = 5.0\text{ V}$ Adjustable Version Only) $T_J = 25^\circ\text{C}$ $T_J = -40\text{ to }+125^\circ\text{C}$	I_b	-	25	100	nA
Oscillator Frequency Note 3 $T_J = 25^\circ\text{C}$ $T_J = 0\text{ to }+125^\circ\text{C}$ $T_J = -40\text{ to }+125^\circ\text{C}$	f_{osc}	-	52	-	kHz
		47	-	58	
		42	-	63	
Saturation Voltage ($I_{out} = 1.0\text{ A}$ Note 4) $T_J = 25^\circ\text{C}$ $T_J = -40\text{ to }+125^\circ\text{C}$	V_{sat}	-	1.0	1.2	V
		-	-	1.3	
Max Duty Cycle ("on") Note 5	D_C	94	98	-	%
Current Limit (Peak Current Notes 4 and 3) $T_J = 25^\circ\text{C}$ $T_J = -40\text{ to }+125^\circ\text{C}$	I_{CL}	1.7	2.3	3.0	A
		1.4	-	3.2	
Output Leakage Current Notes 6 and 7, $T_J = 25^\circ\text{C}$ Output = 0 V Output = -1.0 V	I_L	-	0.8	2.0	mA
		-	6.0	20	
Quiescent Current Note 6 $T_J = 25^\circ\text{C}$ $T_J = -40\text{ to }+125^\circ\text{C}$	I_Q	-	5.0	9.0	mA
		-	-	11	
Standby Quiescent Current (\overline{ON}/OFF Pin = 5.0 V ("off")) $T_J = 25^\circ\text{C}$ $T_J = -40\text{ to }+125^\circ\text{C}$	I_{stby}	15	80	200	μA
		-	-	400	
\overline{ON}/OFF Pin Logic Input Level (Test Circuit Figure 14) $V_{out} = 0\text{ V}$ $T_J = 25^\circ\text{C}$ $T_J = -40\text{ to }+125^\circ\text{C}$ $V_{out} = \text{Nominal Output Voltage}$ $T_J = 25^\circ\text{C}$ $T_J = -40\text{ to }+125^\circ\text{C}$	V_{IH}	2.2	1.4	-	V
		2.4	-	-	
	V_{IL}	-	1.2	1.0	
		-	-	0.8	
\overline{ON}/OFF Pin Input Current (Test Circuit Figure 14) \overline{ON}/OFF Pin = 5.0 V ("off"), $T_J = 25^\circ\text{C}$ \overline{ON}/OFF Pin = 0 V ("on"), $T_J = 25^\circ\text{C}$	I_{IH}	-	15	30	μA
	I_{IL}	-	0	5.0	

3. The oscillator frequency reduces to approximately 18 kHz in the event of an output short or an overload which causes the regulated output voltage to drop approximately 40% from the nominal output voltage. This self protection feature lowers the average dissipation of the IC by lowering the minimum duty cycle from 5% down to approximately 2%.

4. Output (Pin 2) sourcing current. No diode, inductor or capacitor connected to output pin.

5. Feedback (Pin 4) removed from output and connected to 0 V.

6. Feedback (Pin 4) removed from output and connected to +12 V for the Adjustable, 3.3 V, and 5.0 V versions, and +25 V for the 12 V versions, to force the output transistor "off".

7. $V_{in} = 40\text{ V}$.

9. TYPICAL PERFORMANCE CHARACTERISTICS (Circuit of Figure 14)

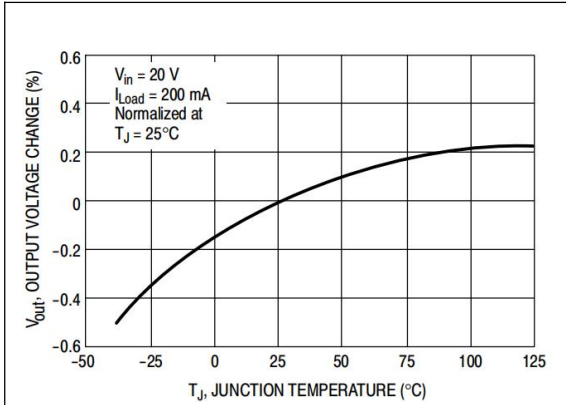

Figure 2. Normalized Output Voltage

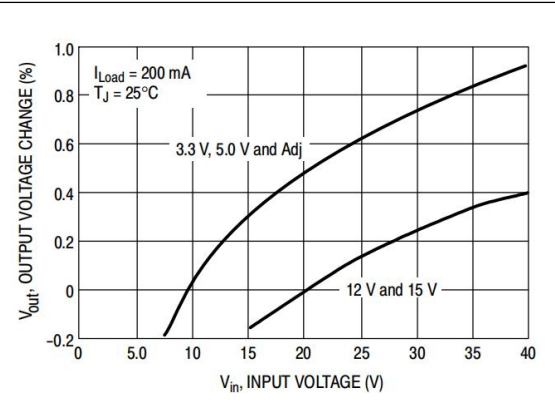

Figure 3. Line Regulation

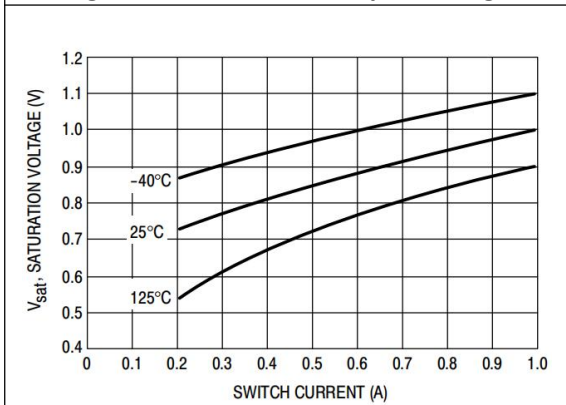

Figure 4. Switch Saturation Voltage

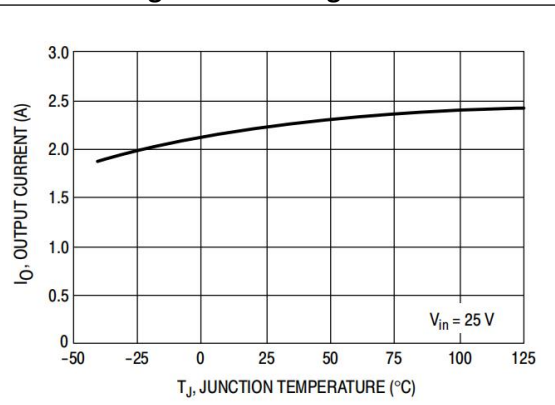

Figure 5. Current Limit

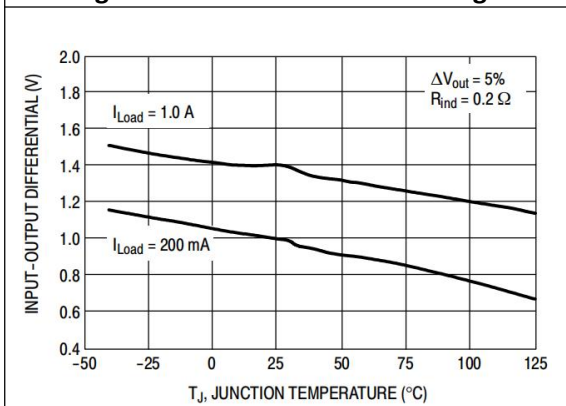

Figure 6. Dropout Voltage

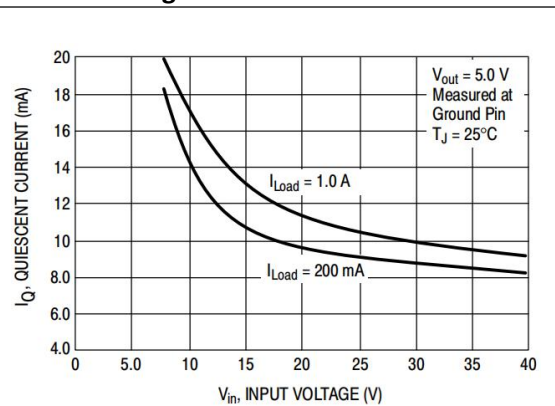

Figure 7. Quiescent Current

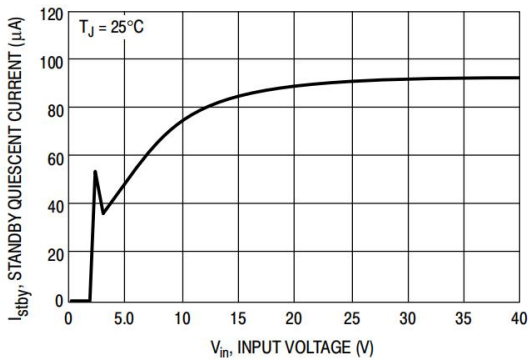

Figure 8. Standby Quiescent Current

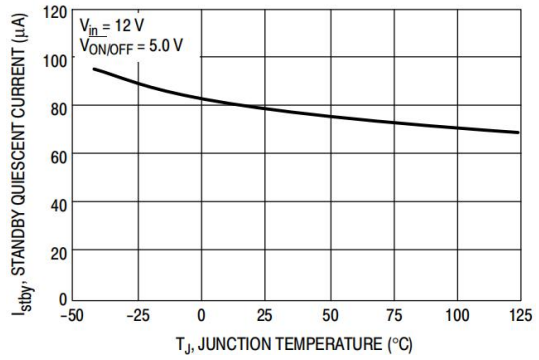

Figure 9. Standby Quiescent Current

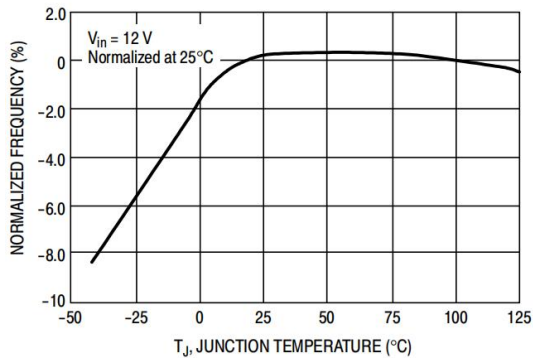

Figure 10. Oscillator Frequency

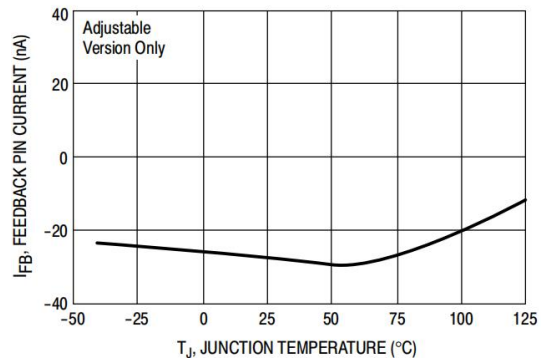

Figure 11. Feedback Pin Current

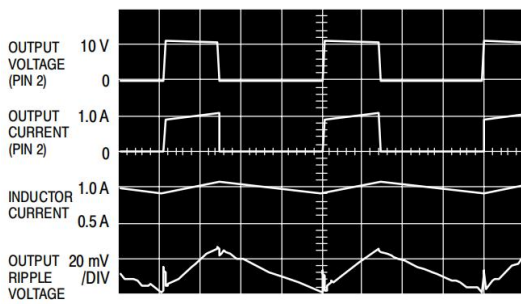

Figure 12. Switching Waveforms

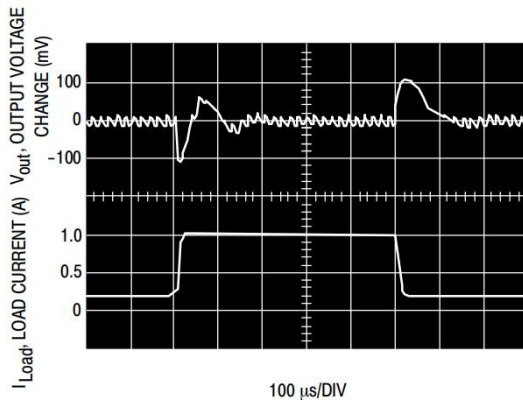
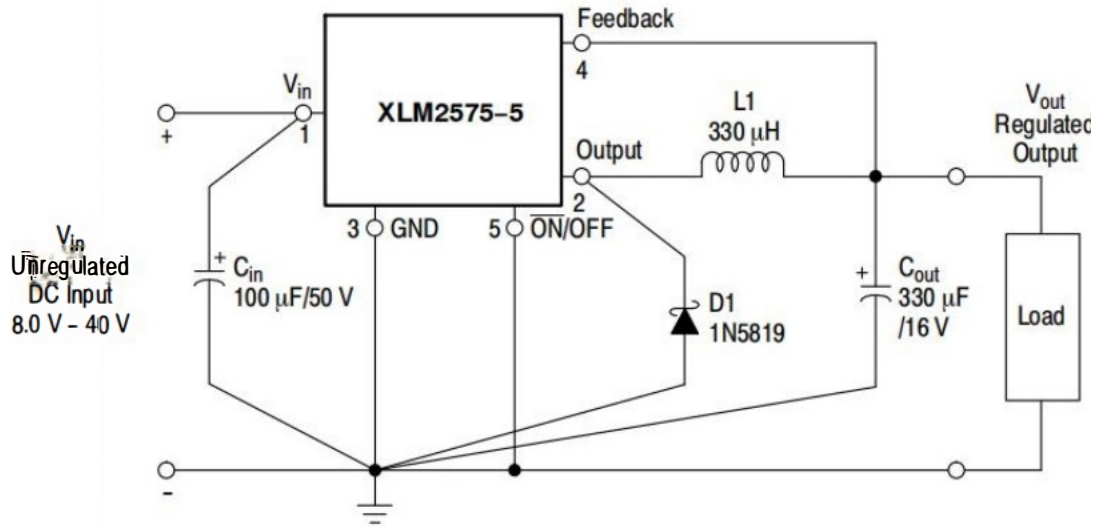
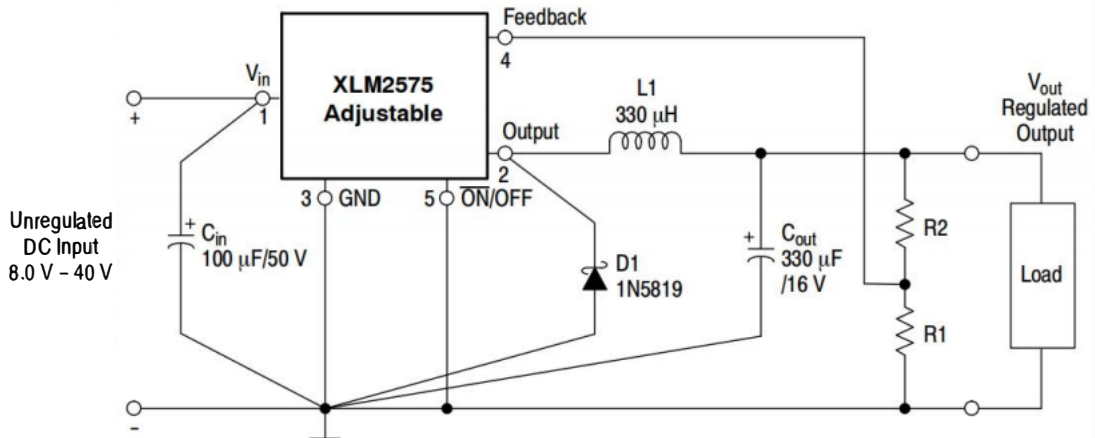

Figure 13. Load Transient Response

5.0 Output Voltage Versions



Adjustable Output Voltage Versions



$$V_{out} = V_{ref} \left(1 + \frac{R2}{R1} \right)$$

$$R2 = R1 \left(\frac{V_{out}}{V_{ref}} - 1 \right)$$

Where $V_{ref} = 1.23 \text{ V}$, $R1$
between 1.0 k and 5.0 k

Figure 14. Typical Test Circuit

10. PCB LAYOUT GUIDELINES

As in any switching regulator, the layout of the printed circuit board is very important. Rapidly switching currents associated with wiring inductance, stray capacitance and parasitic inductance of the printed circuit board traces can generate voltage transients which can generate electromagnetic interferences (EMI) and affect the desired operation. As indicated in the Figure 14, to minimize inductance and ground loops, the length of the leads indicated by heavy lines should be kept as short as possible. For best results, single-point grounding (as indicated) or ground plane construction should be used.

On the other hand, the PCB area connected to the Pin 2 (emitter of the internal switch) of the XLM2575 should be kept to a minimum in order to minimize coupling to sensitive circuitry.

Another sensitive part of the circuit is the feedback. It is important to keep the sensitive feedback wiring short. To assure this, physically locate the programming resistors near to the regulator, when using the adjustable version of the XLM2575 regulator.

11. PIN FUNCTION DESCRIPTION

Pin	Symbol	Description (Refer to Figure 1)
1	Vin	This pin is the positive input supply for the XLM2575 step-down switching regulator. In order to minimize voltage transients and to supply the switching currents needed by the regulator, a suitable input bypass capacitor must be present (Cin in Figure 1).
2	Output	This is the emitter of the internal switch. The saturation voltage Vsat of this output switch is typically 1.0 V. It should be kept in mind that the PCB area connected to this pin should be kept to a minimum in order to minimize coupling to sensitive circuitry.
3	GND	Circuit ground pin.
4	Feedback	This pin senses regulated output voltage to complete the feedback loop. The signal is divided by the internal resistor divider network R2, R1 and applied to the non-inverting input of the internal error amplifier. In the Adjustable version of the XLM2575 switching regulator this pin is the direct input of the error amplifier and the resistor network R2, R1 is connected externally to allow programming of the output voltage.
5	$\overline{\text{ON}}/\text{OFF}$	It allows the switching regulator circuit to be shut down using logic level signals, thus dropping the total input supply current to approximately 80 μA . The input threshold voltage is typically 1.4 V. Applying avoltage above this value (up to +Vin) shuts the regulator off. If the voltage applied to this pin is lower than 1.4 V or if this pin is connected to ground, the regulator will be in the “on” condition.

12. DESIGN PROCEDURE

The XLM2575 is a “Buck” or Step-Down Converter which is the most elementary forward-mode converter. Its basic schematic can be seen in Figure 15.

The operation of this regulator topology has two distinct time periods. The first one occurs when the series switch is on, the input voltage is connected to the input of the inductor.

The output of the inductor is the output voltage, and the rectifier (or catch diode) is reverse biased. During this period, since there is a constant voltage source connected across the inductor, the inductor current begins to linearly ramp upwards, as described by the following equation:

$$I_{L(on)} = \frac{(V_{in} - V_{out}) t_{on}}{L}$$

During this “on” period, energy is stored within the core material in the form of magnetic flux. If the inductor is properly designed, there is sufficient energy stored to carry the requirements of the load during the “off” period.

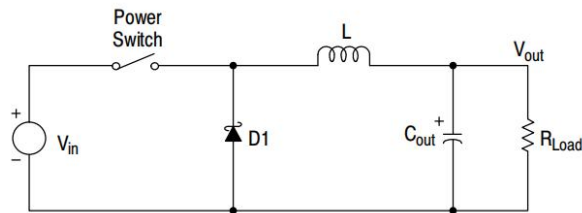

Figure 15. Basic Buck Converter

The next period is the “off” period of the power switch. When the power switch turns off, the voltage across the inductor reverses its polarity and is clamped at one diode voltage drop below ground by catch diode. Current now flows through the catch diode thus maintaining the load current loop. This removes the stored energy from the inductor.

The inductor current during this time is:

$$I_{L(off)} = \frac{(V_{out} + V_D) t_{off}}{L}$$

This period ends when the power switch is once again turned on. Regulation of the converter is accomplished by varying the duty cycle of the power switch. It is possible to describe the duty cycle as follows:

$$d = \frac{t_{on}}{T}, \text{ where } T \text{ is the period of switching.}$$

For the buck converter with ideal components, the duty cycle can also be described as:

$$d = \frac{V_{out}}{V_{in}}$$

Figure 16 shows the buck converter idealized waveforms of the catch diode voltage and the inductor current.

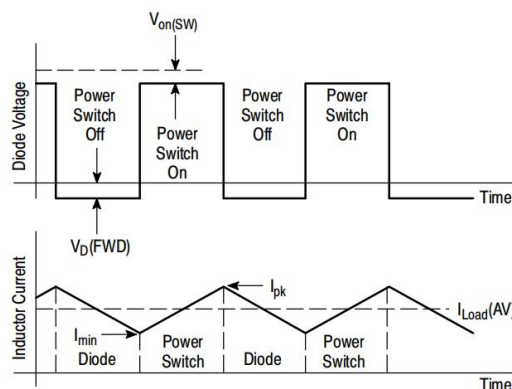

Figure 16. Buck Converter Idealized Waveforms

Procedure (Fixed Output Voltage Version) In order to simplify the switching regulator design, a step-by-step design procedure and example is provided.

Procedure	Example
<p>Given Parameters: V_{out} = Regulated Output Voltage (3.3 V, 5.0 V, 12 V) $V_{in(max)}$ = Maximum DC Input Voltage $I_{Load(max)}$ = Maximum Load Current</p>	<p>Given Parameters: V_{out} = 5.0 V $V_{in(max)}$ = 20 V $I_{Load(max)}$ = 0.8 A</p>
<p>1. Controller IC Selection According to the required input voltage, output voltage and current, select the appropriate type of the controller IC output voltage version</p>	<p>1. Controller IC Selection According to the required input voltage, output voltage, current polarity and current value, use the XLM2575-5 controller IC</p>
<p>2. Input Capacitor Selection (Cin) To prevent large voltage transients from appearing at the input and for stable operation of the converter, an aluminium or tantalum electrolytic bypass capacitor is needed between the input pin +Vin and ground pin GND. This capacitor should be located close to the IC using short leads. This capacitor should have a low ESR (Equivalent Series Resistance) value.</p>	<p>2. Input Capacitor Selection (Cin) A 47µF, 25 V aluminium electrolytic capacitor located near to the input and ground pins provides sufficient bypassing.</p>
<p>3. Catch Diode Selection (D1) A. Since the diode maximum peak current exceeds the regulator maximum load current the catch diode current rating must be at least 1.2 times greater than the maximum load current. For a robust design the diode should have a current rating equal to the maximum current limit of the XLM2575 to be able to withstand a continuous output short B. The reverse voltage rating of the diode should be at least 1.25 times the maximum input voltage.</p>	<p>3. Catch Diode Selection (D1) A. For this example the current rating of the diode is 1.0 A. B. Use a 30 V 1N5818 Schottky diode, or any of the suggested fast recovery diodes shown in the Table 3.</p>
<p>4. Inductor Selection (L1) A. According to the required working conditions, select the correct inductor value using the selection guide from Figures 17 to 21. B. From the appropriate inductor selection guide, identify the inductance region intersected by the Maximum Input Voltage line and the Maximum Load Current line. Each region is identified by an inductance value and an inductor code. C. Select an appropriate inductor from the several different manufacturers part numbers listed in Table 1 or Table 2. When using Table 2 for selecting the right inductor the designer must realize that the inductor current rating must be higher than the maximum peak current flowing through the inductor. This maximum peak current can be calculated as follows:</p> $I_{p(max)} = I_{Load(max)} + \frac{(V_{in} - V_{out}) t_{on}}{2L}$ <p>where t_{on} is the "on" time of the power switch and</p> $t_{on} = \frac{V_{out}}{V_{in}} \times \frac{1}{f_{osc}}$ <p>For additional information about the inductor, see the inductor section in the "External Components" section of this data sheet.</p>	<p>4. Inductor Selection (L1) A. Use the inductor selection guide shown in Figures 17 to 21. B. From the selection guide, the inductance area intersected by the 20 V line and 0.8 A line is L330. C. Inductor value required is 330 µH. From the Table 1 or Table 2, choose an inductor from any of the listed manufacturers.</p>
<p>5. Output Capacitor Selection (Cout) A. Since the XLM2575 is a forward-mode switching regulator with voltage mode control, its open loop 2-pole-2-zero frequency characteristic has the dominant pole-pair determined by the output capacitor and inductor values. For stable operation and an acceptable ripple voltage, (approximately 1% of the output voltage) a value between 100 µF and 470µF is recommended. B. Due to the fact that the higher voltage electrolytic capacitors generally have lower ESR (Equivalent Series Resistance) numbers, the output capacitor's voltage rating should be at least 1.5 times greater than the output voltage. For a 5.0 V regulator, a rating at least 8V is appropriate, and a 10 V or 16 V rating is recommended.</p>	<p>5. Output Capacitor Selection (Cout) A. Cout = 100µF to 470µF standard aluminium electrolytic. B. Capacitor voltage rating = 16 V</p>

Procedure (Adjustable Output Version: XLM2575-Adj)

Procedure	Example
<p>Given Parameters: V_{out} = Regulated Output Voltage $V_{in(max)}$ = Maximum DC Input Voltage $I_{Load(max)}$ = Maximum Load Current</p>	<p>Given Parameters: $V_{out} = 8.0\text{ V}$ $V_{in(max)} = 12\text{ V}$ $I_{Load(max)} = 1.0\text{ A}$</p>
<p>1. Programming Output Voltage To select the right programming resistor R1 and R2 value (see Figure 14) use the following formula: $V_{out} = V_{ref} \left(1 + \frac{R2}{R1} \right)$ where $V_{ref} = 1.23\text{ V}$ Resistor R1 can be between 1.0 k and 5.0 kΩ . (For best temperature coefficient and stability with time, use 1% metal film resistors). $R2 = R1 \left(\frac{V_{out}}{V_{ref}} - 1 \right)$</p>	<p>1. Programming Output Voltage (selecting R1 and R2) Select R1 and R2: $V_{out} = 1.23 \left(1 + \frac{R2}{R1} \right)$ Select $R1 = 1.8\text{ k}\Omega$ $R2 = R1 \left(\frac{V_{out}}{V_{ref}} - 1 \right) = 1.8\text{ k} \left(\frac{8.0\text{ V}}{1.23\text{ V}} - 1 \right)$ $R2 = 9.91\text{ k}\Omega$, choose a 9.88 k metal film resistor.</p>
<p>2. Input Capacitor Selection (Cin) To prevent large voltage transients from appearing at the input and for stable operation of the converter, an aluminium or tantalum electrolytic bypass capacitor is needed between the input pin +V_{in} and ground pin GND This capacitor should be located close to the IC using short leads. This capacitor should have a low ESR (Equivalent Series Resistance) value.</p>	<p>2. Input Capacitor Selection (Cin) A 100 μF aluminium electrolytic capacitor located near the input and ground pin provides sufficient bypassing.</p>
<p>3. Catch Diode Selection (D1) A. Since the diode maximum peak current exceeds the regulator maximum load current the catch diode current rating must be at least 1.2 times greater than the maximum load current. For a robust design, the diode should have a current rating equal to the maximum current limit of the XLM2575 to be able to withstand a continuous output short. B. The reverse voltage rating of the diode should be at least 1.25 times the maximum input voltage.</p>	<p>3. Catch Diode Selection (D1) A. For this example, a 3.0 A current rating is adequate. B. Use a 20 V 1N5820 or MBR320 Schottky diode or any suggested fast recovery diode in the Table 3.</p>
<p>4. Inductor Selection (L1) A. Use the following formula to calculate the inductor Volt x microsecond [V x μs] constant: $E \times T = (V_{in} - V_{out}) \frac{V_{out}}{V_{on}} \times \frac{10^6}{F[\text{Hz}]} \text{ [V x } \mu\text{s]}$ B. Match the calculated E x T value with the corresponding number on the vertical axis of the Inductor Value Selection Guide shown in Figure 21. This E x T constant is a measure of the energy handling capability of an inductor and is dependent upon the type of core, the core area, the number of turns, and the duty cycle. C. Next step is to identify the inductance region intersected by the E x T value and the maximum load current value on the horizontal axis shown in Figure 21. D. From the inductor code, identify the inductor value. Then select an appropriate inductor from the Table 1 or Table 2. The inductor chosen must be rated for a switching frequency of 52 kHz and for a current rating of 1.15 x I_{load}. The inductor current rating can also be determined by calculating the inductor peak current: $I_{p(max)} = I_{Load(max)} + \frac{(V_{in} - V_{out}) t_{on}}{2L}$ where t_{on} is the "on" time of the power switch and $t_{on} = \frac{V_{out}}{V_{in}} \times \frac{1}{f_{osc}}$</p>	<p>4. Inductor Selection (L1) A. Calculate E x T [V x μs] constant $E \times T = (12 - 8.0) \times \frac{8.0}{12} \times \frac{1000}{52} = 51 \text{ [V x } \mu\text{s]}$ B. $E \times T = 51 \text{ [V x } \mu\text{s]}$ C. $I_{Load(max)} = 1.0\text{ A}$ Inductance Region = L220 D. Proper inductor value = 220 μH Choose the inductor from the Table 1 or Table 2</p>

5. Output Capacitor Selection (C_{out})

A. Since the XLM2575 is a forward-mode switching regulator with voltage mode control, its open loop 2-pole-2-zero frequency characteristic has the dominant pole-pair determined by the output capacitor and inductor values. For stable operation, the capacitor must satisfy the following requirement:

$$C_{out} \geq 7.785 \frac{V_{in(max)}}{V_{out} \times L [\mu H]} [\mu F]$$

- B. Capacitor values between 10μF and 2000μF will satisfy the loop requirements for stable operation. To achieve an acceptable output ripple voltage and transient response, the output capacitor may need to be several times larger than the above formula yields.
- C. Due to the fact that the higher voltage electrolytic capacitors generally have lower ESR (Equivalent Series Resistance) numbers, the output capacitor's voltage rating should be at least 1.5 times greater than the output voltage. For a 5.0 V regulator, a rating of at least 8V is appropriate, and a 10 V or 16 V rating is recommended.

5. Output Capacitor Selection (C_{out})

A.

$$C_{out} \geq 7.785 \frac{12}{8.220} = 53 \mu F$$

To achieve an acceptable ripple voltage, select C_{out} = 100 μF electrolytic capacitor.

13. INDUCTOR VALUE SELECTION GUIDE

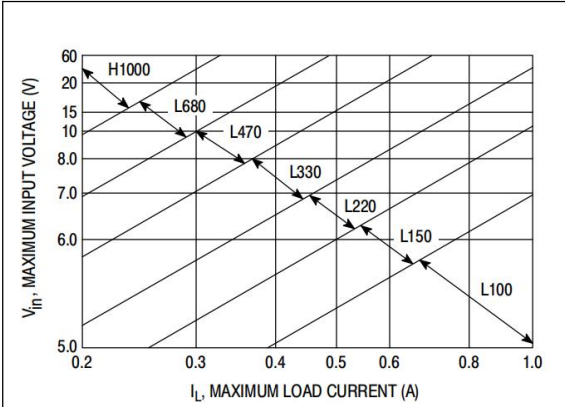

Figure 17. XLM2575-3.3

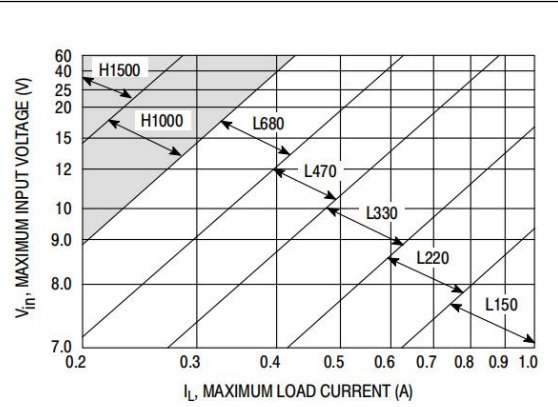

Figure 18. XLM2575-5.0

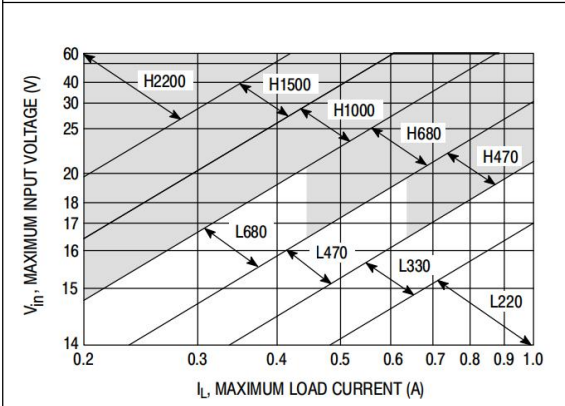

Figure 19. XLM2575-12

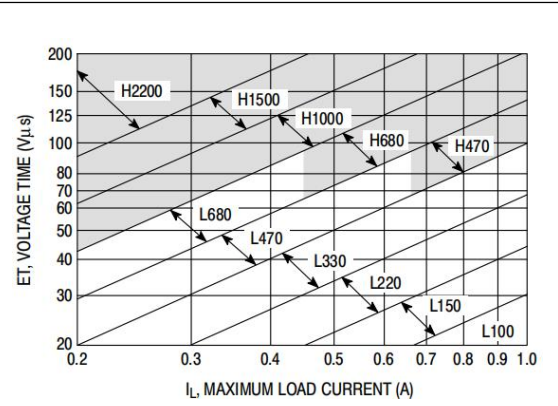

Figure 20. XLM2575-Adj

Table 1. Inductor Selection Guide

Inductor Code	Inductor Value	Pulse Eng	Renco	AIE	Tech 39
L100	100 μ H	PE-92108	RL2444	415-0930	77 308 BV
L150	150 μ H	PE-53113	RL1954	415-0953	77 358 BV
L220	220 μ H	PE-52626	RL1953	415-0922	77 408 BV
L330	330 μ H	PE-52627	RL1952	415-0926	77 458 BV
L470	470 μ H	PE-53114	RL1951	415-0927	-
L680	680 μ H	PE-52629	RL1950	415-0928	77 508 BV
H150	150 μ H	PE-53115	RL2445	415-0936	77 368 BV
H220	220 μ H	PE-53116	RL2446	430-0636	77 410 BV
H330	330 μ H	PE-53117	RL2447	430-0635	77 460 BV
H470	470 μ H	PE-53118	RL1961	430-0634	-
H680	680 μ H	PE-53119	RL1960	415-0935	77 510 BV
H1000	1000 μ H	PE-53120	RL1959	415-0934	77 558 BV
H1500	1500 μ H	PE-53121	RL1958	415-0933	-
H2200	2200 μ H	PE-53122	RL2448	415-0945	77 610 BV

Table 2. Inductor Selection Guide

Inductance (μ H)	Current (A)	Schott		Renco		Pulse Engineering		Coilcraft
		THT	SMT	THT	SMT	THT	SMT	SMT
68	0.32	67143940	67144310	RL-1284-68-43	RL1500-68	PE-53804	PE-53804-S	DO1608-68
	0.58	67143990	67144360	RL-5470-6	RL1500-68	PE-53812	PE-53812-S	DO3308-683
	0.99	67144070	67144450	RL-5471-5	RL1500-68	PE-53821	PE-53821-S	DO3316-683
	1.78	67144140	67144520	RL-5471-5	-	PE-53830	PE-53830-S	DO5022P-683
100	0.48	67143980	67144350	RL-5470-5	RL1500-100	PE-53811	PE-53811-S	DO3308-104
	0.82	67144060	67144440	RL-5471-4	RL1500-100	PE-53820	PE-53820-S	DO3316-104
	1.47	67144130	67144510	RL-5471-4	-	PE-53829	PE-53829-S	DO5022P-104
150	0.39	-	67144340	RL-5470-4	RL1500-150	PE-53810	PE-53810-S	DO3308-154
	0.66	67144050	67144430	RL-5471-3	RL1500-150	PE-53819	PE-53819-S	DO3316-154
	1.20	67144120	67144500	RL-5471-3	-	PE-53828	PE-53828-S	DO5022P-154
220	0.32	67143960	67144330	RL-5470-3	RL1500-220	PE-53809	PE-53809-S	DO3308-224
	0.55	67144040	67144420	RL-5471-2	RL1500-220	PE-53818	PE-53818-S	DO3316-224
	1.00	67144110	67144490	RL-5471-2	-	PE-53827	PE-53827-S	DO5022P-224
330	0.42	67144030	67144410	RL-5471-1	RL1500-330	PE-53817	PE-53817-S	DO3316-334
	0.80	67144100	67144480	RL-5471-1	-	PE-53826	PE-53826-S	DO5022P-334

NOTE: Table 1 and Table 2 of this Indicator Selection Guide shows some examples of different manufacturer products suitable for design with the XLM2575.

Table 3. Diode Selection Guide gives an overview about both surface_mount and through_hole diodes for an effective design. Device listed in bold are available from ON Semiconductor.

V _R	Schottky				Ultra_Fast Recovery			
	1.0 A		3.0 A		1.0 A		3.0 A	
	SMT	THT	SMT	THT	SMT	THT	SMT	THT
20 V	SK12	1N5817 SR102	SK32 MBRD320	1N5820 MBR320 SR302	MURS120T3 10BF10	MUR120 11DF1 HER102	MURS320T3 MURD320	MUR320 30WF10 MUR420
30 V	MBRS130LT3 SK13	1N5818 SR103 11DQ03	SK33 MBRD330	1N5821 MBR330 SR303 31DQ03				
40 V	MBRS140T3 SK14 10BQ040 10MQ040	1N5819 SR104 11DQ04	MBRS340T3 MBRD340 30WQ04 SK34	1N5822 MBR340 SR304 31DQ04				
50 V	MBRS150 10BQ050	MBR150 SR105 11DQ05	MBRD350 SK35 30WQ05	MBR350 SR305 11DQ05				

14. EXTERNAL COMPONENTS

14.1. Input Capacitor (Cin) The Input Capacitor Should Have a Low ESR

For stable operation of the switch mode converter a low ESR (Equivalent Series Resistance) aluminium or solid tantalum bypass capacitor is needed between the input pin and the ground pin to prevent large voltage transients from appearing at the input. It must be located near the regulator and use short leads. With most electrolytic capacitors, the capacitance value decreases and the ESR increases with lower temperatures. For reliable operation in temperatures below -25°C larger values of the input capacitor may be needed. Also paralleling a ceramic or solid tantalum capacitor will increase the regulator stability at cold temperatures.

14.2. RMS Current Rating of Cin

The important parameter of the input capacitor is the RMS current rating. Capacitors that are physically large and have large surface area will typically have higher RMS current ratings. For a given capacitor value, a higher voltage electrolytic capacitor will be physically larger than a lower voltage capacitor, and thus be able to dissipate more heat to the surrounding air, and therefore will have a higher RMS current rating. The consequence of operating an electrolytic capacitor above the RMS current rating is a shortened operating life. In order to assure maximum capacitor operating lifetime, the capacitor's RMS ripple current rating should be:

$$I_{\text{rms}} > 1.2 \times d \times I_{\text{Load}}$$

where d is the duty cycle, for a buck regulator

$$d = \frac{t_{\text{on}}}{T} = \frac{V_{\text{out}}}{V_{\text{in}}}$$

and $d = \frac{t_{\text{on}}}{T} = \frac{|V_{\text{out}}|}{|V_{\text{out}}| + V_{\text{in}}}$ for a buck-boost regulator.

14.3. Output Capacitor (Cout)

For low output ripple voltage and good stability, low ESR output capacitors are recommended. An output capacitor has two main functions: it filters the output and provides regulator loop stability. The ESR of the output capacitor and the peak-to-peak value of the inductor ripple current are the main factors contributing to the output ripple voltage value. Standard aluminium electrolytics could be adequate for some applications but for quality design low ESR types are recommended.

An aluminium electrolytic capacitor's ESR value is related to many factors such as the capacitance value, the

voltage rating, the physical size and the type of construction. In most cases, the higher voltage electrolytic capacitors have lower ESR value. Often capacitors with much higher voltage ratings may be needed to provide low ESR values that are required for low output ripple voltage.

14.4. The Output Capacitor Requires an ESR Value That Has an Upper and Lower Limit

As mentioned above, a low ESR value is needed for low output ripple voltage, typically 1% to 2% of the output voltage. But if the selected capacitor's ESR is extremely low (below 0.05Ω), there is a possibility of an unstable feedback loop, resulting in oscillation at the output. This situation can occur when a tantalum capacitor, that can have a very low ESR, is used as the only output capacitor.

14.5. At Low Temperatures, Put in Parallel Aluminium Electrolytic Capacitors with Tantalum Capacitors

Electrolytic capacitors are not recommended for temperatures below -25°C . The ESR rises dramatically at cold temperatures and typically rises 3 times at -25°C and as much as 10 times at -40°C . Solid tantalum capacitors have much better ESR spec at cold temperatures and are recommended for temperatures below -25°C . They can be also used in parallel with aluminium electrolytics. The value of the tantalum capacitor should be about 10% or 20% of the total capacitance. The output capacitor should have at least 50% higher RMS ripple current rating at 52 kHz than the peak-to-peak inductor ripple current.

14.6. Catch Diode Locate the Catch Diode Close to the XLM2575

The XLM2575 is a step-down buck converter; it requires a fast diode to provide a return path for the inductor current when the switch turns off. This diode must be located close to the XLM2575 using short leads and short printed circuit traces to avoid EMI problems.

14.7. Use a Schottky or a Soft Switching Ultra-Fast Recovery Diode

Since the rectifier diodes are very significant source of losses within switching power supplies, choosing the rectifier that best fits into the converter design is an important process. Schottky diodes provide the best performance because of their fast switching speed and low forward voltage drop.

They provide the best efficiency especially in low output voltage applications (5.0 V and lower). Another choice could be Fast-Recovery, or Ultra-Fast Recovery diodes. It has to be noted, that some types of these diodes with an abrupt turnoff characteristic may cause instability or EMI troubles.

A fast-recovery diode with soft recovery characteristics can better fulfill a quality, low noise design requirements. Table 3 provides a list of suitable diodes for the XLM2575 regulator. Standard 50/60 Hz rectifier diodes such as the 1N4001 series or 1N5400 series are NOT suitable.

14.8. Inductor

The magnetic components are the cornerstone of all switching power supply designs. The style of the core and the winding technique used in the magnetic component's design has a great influence on the reliability of the overall power supply.

Using an improper or poorly designed inductor can cause high voltage spikes generated by the rate of transitions in current within the switching power supply, and the possibility of core saturation can arise during an abnormal operational mode. Voltage spikes can cause the semiconductors to enter avalanche breakdown and the part can instantly fail if enough energy is applied. It can also cause significant RFI (Radio Frequency Interference) and EMI (Electro-Magnetic Interference) problems.

14.9. Continuous and Discontinuous Mode of Operation

The XLM2575 step-down converter can operate in both the continuous and the discontinuous modes of operation. The regulator works in the continuous mode when loads are relatively heavy, the current flows through the inductor continuously and never falls to zero. Under light load conditions, the circuit will be forced to the discontinuous mode when inductor current falls to zero for certain period of time (see Figure 22 and Figure 23). Each mode has distinctively different operating characteristics, which can affect the regulator performance and requirements. In many cases the preferred mode of operation is the continuous mode. It offers greater output power, lower peak currents in the switch, inductor and diode, and can have a lower output ripple voltage. On the other hand it does require larger inductor values to keep the inductor current flowing continuously, especially at low output load currents and/or high input voltages.

To simplify the inductor selection process, an inductor selection guide for the XLM2575 regulator was added to this data sheet (Figures 17 through 20). This guide assumes that the regulator is operating in the continuous mode, and selects an inductor that will allow a peak-to-peak inductor ripple current to be a certain percentage of the maximum design load current. This percentage is allowed to change as different design load currents are selected. For light loads (less than approximately 200 mA) it may be desirable to operate the regulator in the discontinuous mode, because the inductor value and size can be kept relatively low. Consequently, the percentage of inductor peak-to-peak current increases. This discontinuous mode of operation is perfectly acceptable for this type of switching converter. Any buck regulator will be forced to enter discontinuous mode if the load current is light enough.

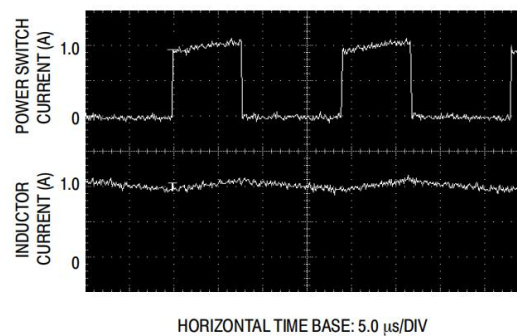

Figure 22. Continuous Mode Switching Current Waveforms

14.10. Selecting the Right Inductor Style

Some important considerations when selecting a core type are core material, cost, the output power of the power supply, the physical volume the inductor must fit within, and the amount of EMI (Electro-Magnetic Interference) shielding that the core must provide. The inductor selection guide covers different styles of inductors, such as pot core, E-core, toroid and bobbin core, as well as different core materials such as ferrites and powdered iron from different manufacturers.

For high quality design regulators the toroid core seems to be the best choice. Since the magnetic flux is completely contained within the core, it generates less EMI, reducing noise problems in sensitive circuits. The least expensive is the bobbin core type, which consists of wire wound on a ferrite rod core. This type of inductor generates more EMI due to the fact that its core is open, and the magnetic flux is not completely contained within the core.

When multiple switching regulators are located on the same printed circuit board, open core magnetics can cause interference between two or more of the regulator circuits, especially at high currents due to mutual coupling. A toroid, pot core or E-core (closed magnetic structure) should be used in such applications.

14.11. Do Not Operate an Inductor Beyond its Maximum Rated Current

Exceeding an inductor's maximum current rating may cause the inductor to overheat because of the copper wire losses, or the core may saturate. Core saturation occurs when the flux density is too high and consequently the cross sectional area of the core can no longer support additional lines of magnetic flux.

This causes the permeability of the core to drop, the inductance value decreases rapidly and the inductor begins to look mainly resistive. It has only the dc resistance of the winding. This can cause the switch current to rise very rapidly and force the XLM2575 internal switch into cycle-by-cycle current limit, thus reducing the dc output load current. This can also result in overheating of the inductor and/or the XLM2575. Different inductor types have different saturation characteristics, and this should be kept in mind when selecting an inductor.

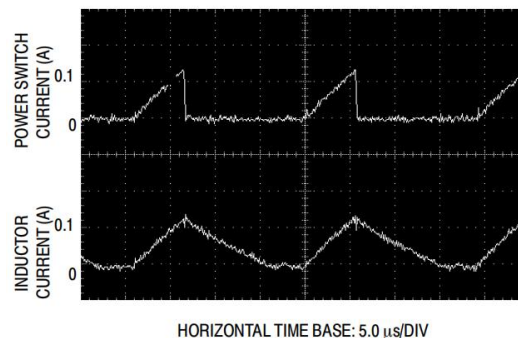

Figure 23. Discontinuous Mode Switching Current Waveforms

15. GENERAL RECOMMENDATIONS

15.1. Output Voltage Ripple and Transients Source of the Output Ripple

Since the XLM2575 is a switch mode power supply regulator, its output voltage, if left unfiltered, will contain a sawtooth ripple voltage at the switching frequency. The output ripple voltage value ranges from 0.5% to 3% of the output voltage. It is caused mainly by the inductor sawtooth ripple current multiplied by the ESR of the output capacitor.

15.2. Short Voltage Spikes and How to Reduce Them

The regulator output voltage may also contain short voltage spikes at the peaks of the sawtooth waveform (see Figure 24). These voltage spikes are present because of the fast switching action of the output switch, and the parasitic inductance of the output filter capacitor. There are some other important factors such as wiring inductance, stray capacitance, as well as the scope probe used to evaluate these transients, all these contribute to the amplitude of these spikes. To minimize these voltage spikes, low inductance capacitors should be used, and their lead lengths must be kept short. The importance of quality printed circuit board layout design should also be highlighted.

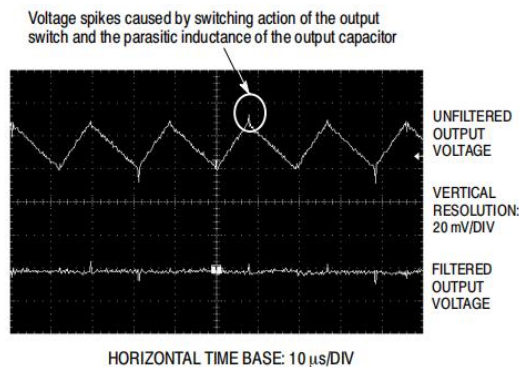

Figure 24. Output Ripple Voltage Waveforms

15.3. Minimizing the Output Ripple

In order to minimize the output ripple voltage it is possible to enlarge the inductance value of the inductor L1 and/or to use a larger value output capacitor. There is also another way to smooth the output by means of an additional LC filter (20 μ H, 100 μ F), that can be added to the output (see Figure 33) to further reduce the amount of output ripple and transients. With such a filter it is possible to reduce the output ripple voltage transients 10 times or more. Figure 24 shows the difference between filtered and unfiltered output waveforms of the regulator shown in Figure 33.

The upper waveform is from the normal unfiltered output of the converter, while the lower waveform shows the output ripple voltage filtered by an additional LC filter.

15.4. The Surface Mount Package TO263 and its Heatsinking

The copper and the board are the heatsink for this package and the other heat producing components, such as the catch diode and inductor. The PC board copper area that the package is soldered to should be at least 0.4 in² (or 100 mm²) and ideally should have 2 or more square inches (1300 mm²) of 0.0028 inch copper. Additional increasing of copper area beyond approximately 3.0 in² (2000 mm²) will not improve heat dissipation significantly. If further thermal improvements are needed, double sided or multilayer PC boards with large copper areas should be considered.

15.5. Thermal Analysis and Design

The following procedure must be performed to determine whether or not a heatsink will be required. First determine:

1. $P_{D(max)}$ maximum regulator power dissipation in the application.
2. $T_{A(max)}$ maximum ambient temperature in the application.
3. $T_{J(max)}$ maximum allowed junction temperature (125°C for the XLM2575). For a conservative design, the maximum junction temperature should not exceed 110°C to assure safe operation. For every additional 10°C temperature rise that the junction must withstand, the estimated operating lifetime of the component is halved.
4. $R_{\theta JC}$ package thermal resistance junction–case.
5. $R_{\theta JA}$ package thermal resistance junction–ambient.

(Refer to Absolute Maximum Ratings in this data sheet or $R_{\theta JC}$ and $R_{\theta JA}$ values).

The following formula is to calculate the total power dissipated by the XLM2575:

$$P_D = (V_{in} \times I_Q) + d \times I_{Load} \times V_{sat}$$

where d is the duty cycle and for buck converter

$$d = \frac{t_{on}}{T} = \frac{V_O}{V_{in}},$$

I_Q (quiescent current) and V_{sat} can be found in the XLM2575 data sheet,

V_{in} is minimum input voltage applied,

V_O is the regulator output voltage,

I_{Load} is the load current.

The dynamic switching losses during turn–on and turn–off can be neglected if proper type catch diode is used.

15.6. Packages Not on a Heatsink (Free-Standing)

For a free-standing application when no heatsink is used, the junction temperature can be determined by the following expression:

$$T_J = (R_{\theta JA}) (P_D) + T_A$$

where $(R_{\theta JA})(P_D)$ represents the junction temperature rise caused by the dissipated power and T_A is the maximum ambient temperature.

15.7. Packages on a Heatsink

If the actual operating junction temperature is greater than the selected safe operating junction temperature determined in step 3, then a heatsink is required. The junction temperature will be calculated as follows:

$$T_J = P_D (R_{\theta JA} + R_{\theta CS} + R_{\theta SA}) + T_A$$

where $R_{\theta JC}$ is the thermal resistance junction-case,

$R_{\theta CS}$ is the thermal resistance case-heatsink,

$R_{\theta SA}$ is the thermal resistance heatsink-ambient.

If the actual operating temperature is greater than the selected safe operating junction temperature, then a larger heatsink is required.

15.8. Some Aspects That can Influence Thermal Design

It should be noted that the package thermal resistance and the junction temperature rise numbers are all approximate, and there are many factors that will affect these numbers, such as PC board size, shape, thickness, physical position, location, board temperature, as well as whether the surrounding air is moving or still.

Other factors are trace width, total printed circuit copper area, copper thickness, single- or double-sided, multilayer board, the amount of solder on the board or even color of the traces.

The size, quantity and spacing of other components on the board can also influence its effectiveness to dissipate the heat.

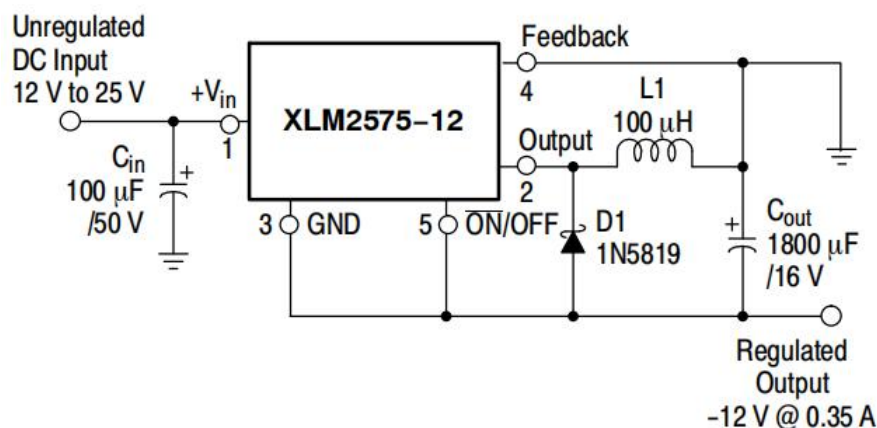

Figure 25. Inverting Buck-Boost Regulator Using the XLM2575-12 Develops -12 V @ 0.35 A

16. ADDITIONAL APPLICATIONS

16.1. Inverting Regulator

An inverting buck–boost regulator using the XLM2575–12 is shown in Figure 25. This circuit converts a positive input voltage to a negative output voltage with a common ground by bootstrapping the regulators ground to the negative output voltage. By grounding the feedback pin, the regulator senses the inverted output voltage and regulates it.

In this example the XLM2575–12 is used to generate a –12 V output. The maximum input voltage in this case cannot exceed +28 V because the maximum voltage appearing across the regulator is the absolute sum of the input and output voltages and this must be limited to a maximum of 40 V.

This circuit configuration is able to deliver approximately 0.35 A to the output when the input voltage is 12 V or higher. At lighter loads the minimum input voltage required drops to approximately 4.7 V, because the buck–boost regulator topology can produce an output voltage that, in its absolute value, is either greater or less than the input voltage.

Since the switch currents in this buck–boost configuration are higher than in the standard buck converter topology, the available output current is lower.

This type of buck–boost inverting regulator can also require a larger amount of startup input current, even for light loads. This may overload an input power source with a current limit less than 1.5 A.

Such an amount of input startup current is needed for at least 2.0 ms or more. The actual time depends on the output voltage and size of the output capacitor.

Because of the relatively high startup currents required by this inverting regulator topology, the use of a delayed startup or an undervoltage lockout circuit is recommended.

Using a delayed startup arrangement, the input capacitor can charge up to a higher voltage before the switch–mode regulator begins to operate.

The high input current needed for startup is now partially supplied by the input capacitor C_{in} .

16.2. Design Recommendations:

The inverting regulator operates in a different manner than the buck converter and so a different design procedure has to be used to select the inductor L_1 or the output capacitor C_{out} .

The output capacitor values must be larger than is normally required for buck converter designs. Low input voltages or high output currents require a large value output capacitor (in the range of thousands of μF).

The recommended range of inductor values for the inverting converter design is between $68\mu\text{H}$ and $220\mu\text{H}$. To select an inductor with an appropriate current rating, the inductor peak current has to be calculated.

The following formula is used to obtain the peak inductor current:

$$I_{\text{peak}} \approx \frac{I_{\text{Load}} (V_{\text{in}} + |V_{\text{O}}|)}{V_{\text{in}}} + \frac{V_{\text{in}} \times t_{\text{on}}}{2L_1}$$

where $t_{\text{on}} = \frac{|V_{\text{O}}|}{V_{\text{in}} + |V_{\text{O}}|} \times \frac{1}{f_{\text{osc}}}$, and $f_{\text{osc}} = 52 \text{ kHz}$.

Under normal continuous inductor current operating conditions, the worst case occurs when V_{in} is minimal.

Note that the voltage appearing across the regulator is the absolute sum of the input and output voltage, and must not exceed 40 V.

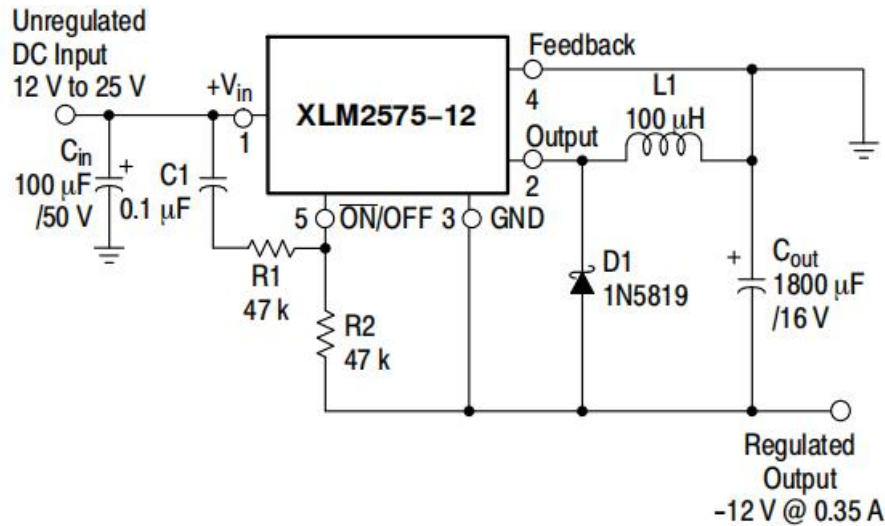
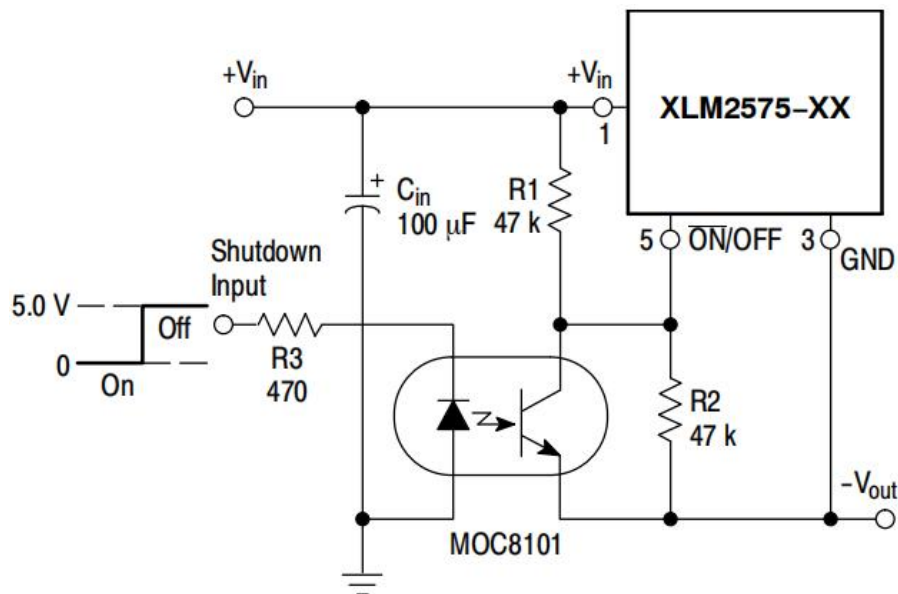

Figure 26. Inverting Buck–Boost Regulator with Delayed Startup

It has been already mentioned above, that in some situations, the delayed startup or the undervoltage lockout features could be very useful. A delayed startup circuit applied to a buck–boost converter is shown in Figure 26. Figure 32 in the “Undervoltage Lockout” section describes an undervoltage lockout feature for the same converter topology.



NOTE: This picture does not show the complete circuit.

Figure 27. Inverting Buck–Boost Regulator Shut Down Circuit Using an Optocoupler

With the inverting configuration, the use of the $\overline{\text{ON}}/\text{OFF}$ pin requires some level shifting techniques. This is caused by the fact, that the ground pin of the converter IC is no longer at ground. Now, the $\overline{\text{ON}}/\text{OFF}$ pin threshold voltage (1.4 V approximately) has to be related to the negative output voltage level. There are many different possible shut down methods, two of them are shown in Figures 27 and 28.

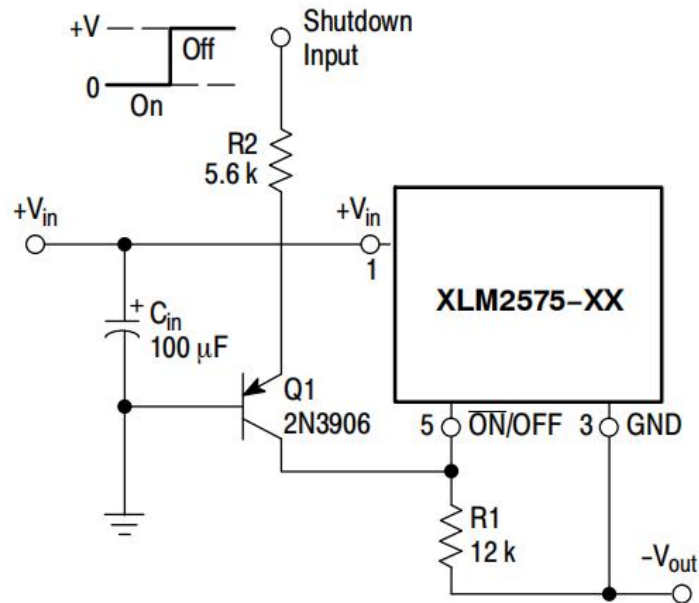

NOTE: This picture does not show the complete circuit.

Figure 28. Inverting Buck-Boost Regulator Shut Down Circuit Using a PNP Transistor

16.3. Negative Boost Regulator

This example is a variation of the buck-boost topology and is called a negative boost regulator. This regulator experiences relatively high switch current, especially at low input voltages. The internal switch current limiting results in lower output load current capability.

The circuit in Figure 29 shows the negative boost configuration. The input voltage in this application ranges from -5.0 V to -12 V and provides a regulated -12 V output. If the input voltage is greater than -12 V, the output will rise above -12 V accordingly, but will not damage the regulator.

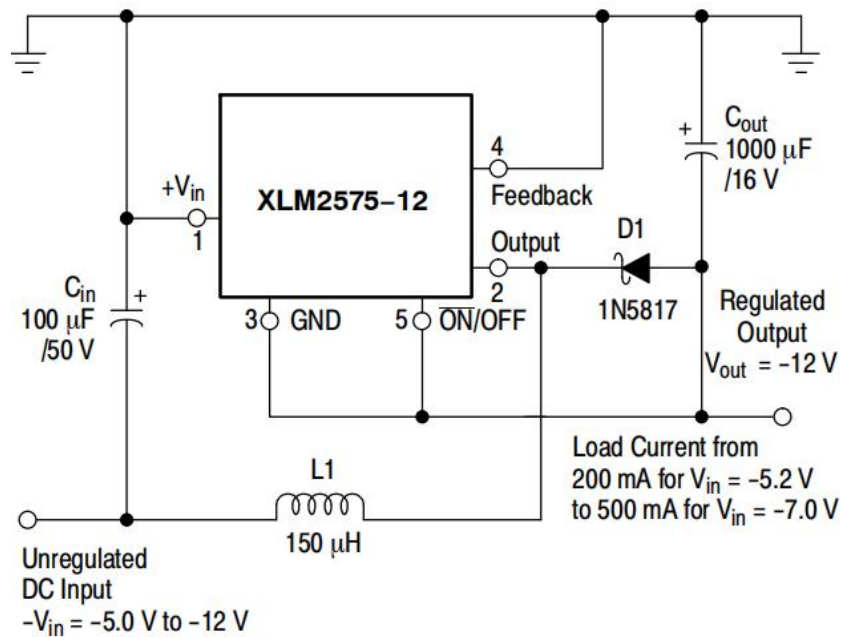

Figure 29. Negative Boost Regulator

16.4. Design Recommendations:

The same design rules as for the previous inverting buck-boost converter can be applied. The output capacitor C_{out} must be chosen larger than would be required for a standard buck converter. Low input voltages or high output currents require a large value output capacitor (in the range of thousands of μF). The recommended range of inductor values for the negative boost regulator is the same as for inverting converter design.

Another important point is that these negative boost converters cannot provide current limiting load protection in the event of a short in the output so some other means, such as a fuse, may be necessary to provide the load protection.

16.5. Delayed Startup

There are some applications, like the inverting regulator already mentioned above, which require a higher amount of startup current. In such cases, if the input power source is limited, this delayed startup feature becomes very useful.

To provide a time delay between the time the input voltage is applied and the time when the output voltage comes up, the circuit in Figure 30 can be used. As the input voltage is applied, the capacitor $C1$ charges up, and the voltage across the resistor $R2$ falls down. When the voltage on the $\overline{\text{ON}}/\text{OFF}$ pin falls below the threshold value 1.4 V, the regulator starts up. Resistor $R1$ is included to limit the maximum voltage applied to the $\overline{\text{ON}}/\text{OFF}$ pin, reduces the power supply noise sensitivity, and also limits the capacitor $C1$ discharge current, but its use is not mandatory.

When a high 50 Hz or 60 Hz (100 Hz or 120 Hz respectively) ripple voltage exists, a long delay time can cause some problems by coupling the ripple into the $\overline{\text{ON}}/\text{OFF}$ pin, the regulator could be switched periodically on and off with the line (or double) frequency.

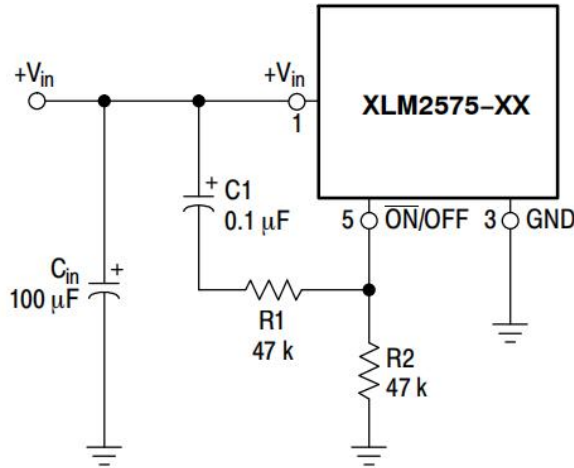

NOTE: This picture does not show the complete circuit.

Figure 30. Delayed Startup Circuitry

16.6. Undervoltage Lockout

Some applications require the regulator to remain off until the input voltage reaches a certain threshold level. Figure 31 shows an undervoltage lockout circuit applied to a buck regulator. A version of this circuit for buck-boost converter is shown in Figure 32. Resistor R3 pulls the $\overline{\text{ON/OFF}}$ pin high and keeps the regulator off until the input voltage reaches a predetermined threshold level, which is determined by the following expression:

$$V_{th} \approx V_{Z1} + \left(1 + \frac{R2}{R1}\right) V_{BE} (Q1)$$

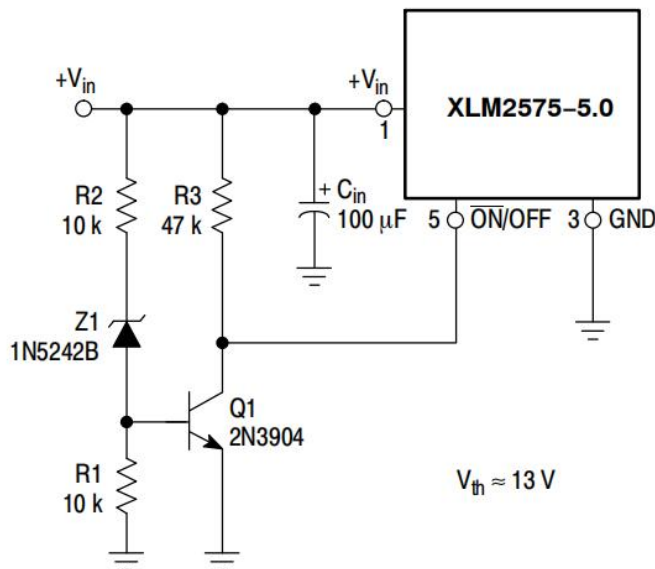

NOTE: This picture does not show the complete circuit.

Figure 31. Undervoltage Lockout Circuit for Buck Converter

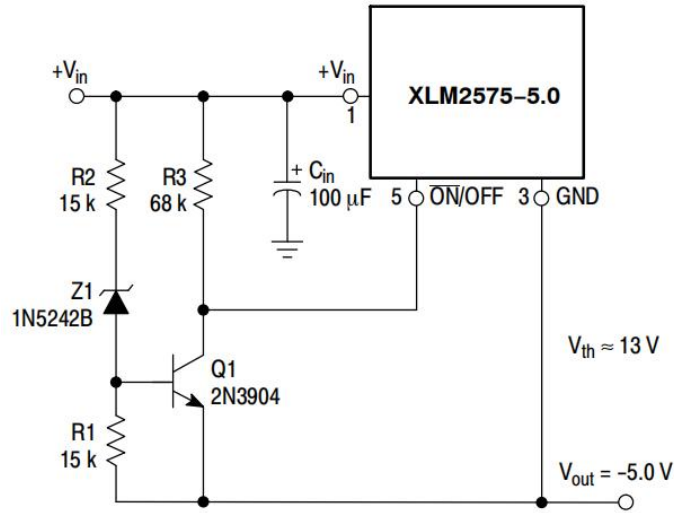

NOTE: This picture does not show the complete circuit.

Figure 32. Undervoltage Lockout Circuit for Buck-Boost Converter

16.7. Adjustable Output, Low-Ripple Power Supply

A 1.0 A output current capability power supply that features an adjustable output voltage is shown in Figure 33.

This regulator delivers 1.0 A into 1.2 V to 35 V output. The input voltage ranges from roughly 8.0 V to 40 V. In order to achieve a 10 or more times reduction of output ripple, an additional L-C filter is included in this circuit.

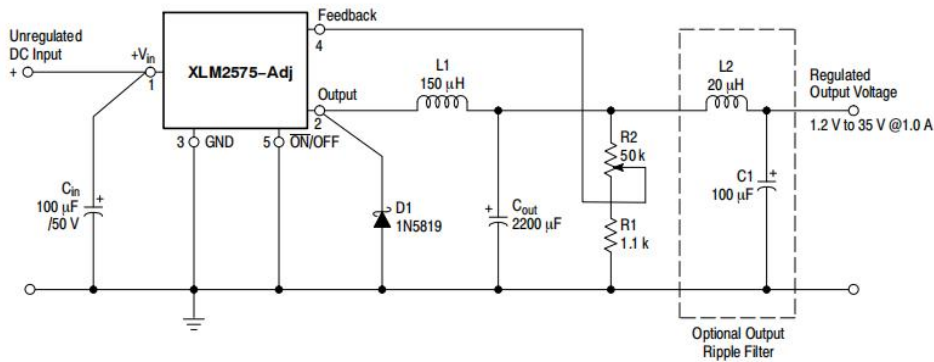

Figure 33. Adjustable Power Supply with Low Ripple Voltage

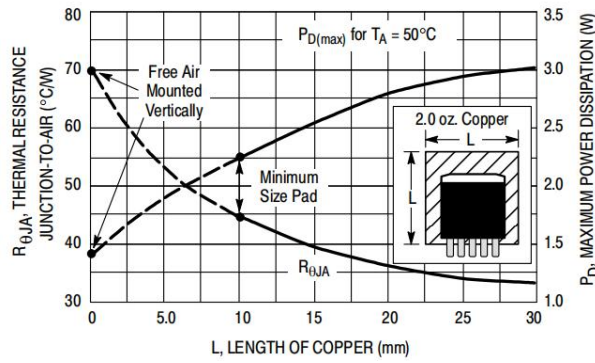

Figure 34. D2PAK Thermal Resistance and Maximum Power Dissipation versus P.C.B. Copper Length

THE XLM2575-5.0 STEP-DOWN VOLTAGE REGULATOR WITH 5.0 V @ 1.0 A OUTPUT POWER CAPABILITY. TYPICAL APPLICATION WITH THROUGH-HOLE PC BOARD LAYOUT

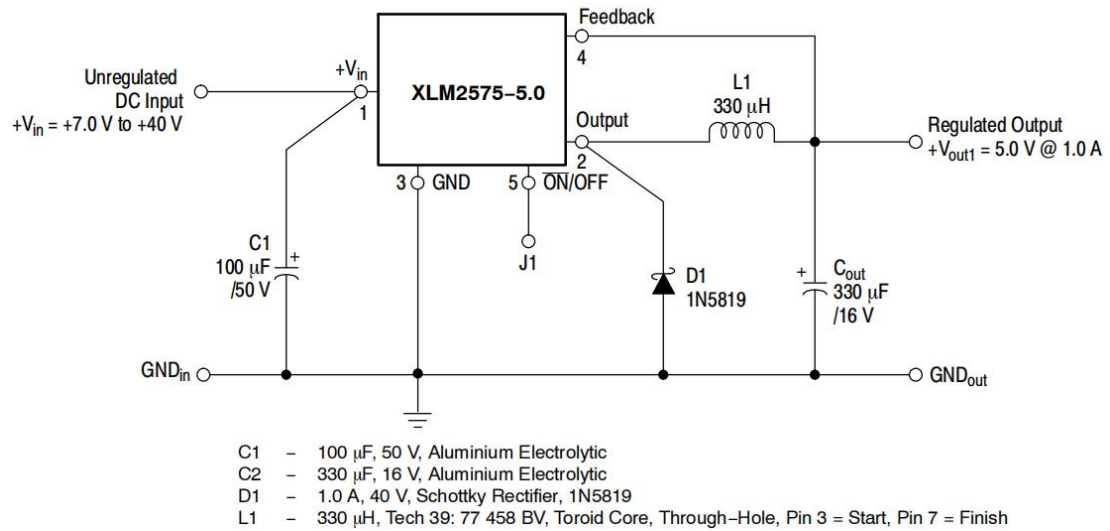

Figure 35. Schematic Diagram of the XLM2575-5.0 Step-Down Converter

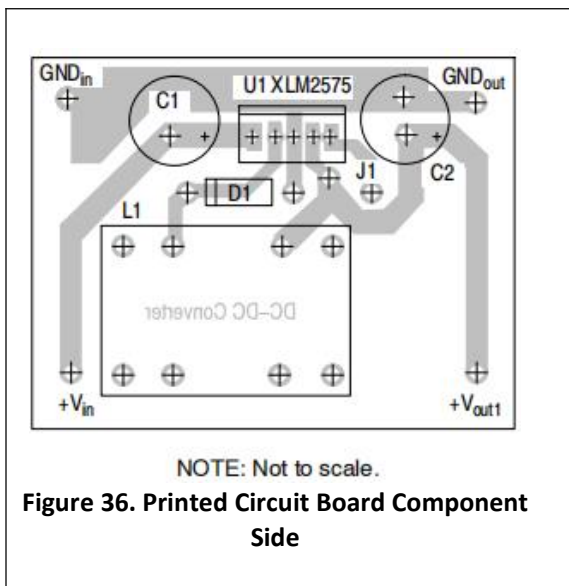
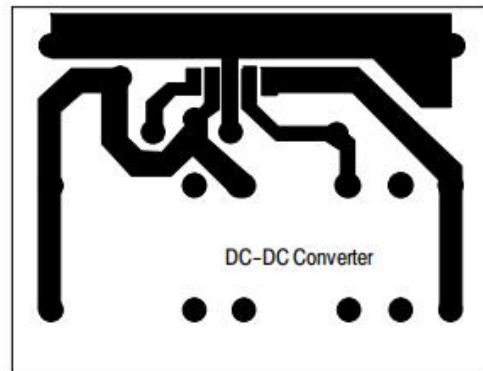

Figure 36. Printed Circuit Board Component Side



NOTE: Not to scale.
Figure 37. Printed Circuit Board Copper Side

THE XLM2575-ADJ STEP-DOWN VOLTAGE REGULATOR WITH 8.0 V @ 1.0 A OUTPUT POWER CAPABILITY. TYPICAL APPLICATION WITH THROUGH-HOLE PC BOARD LAYOUT

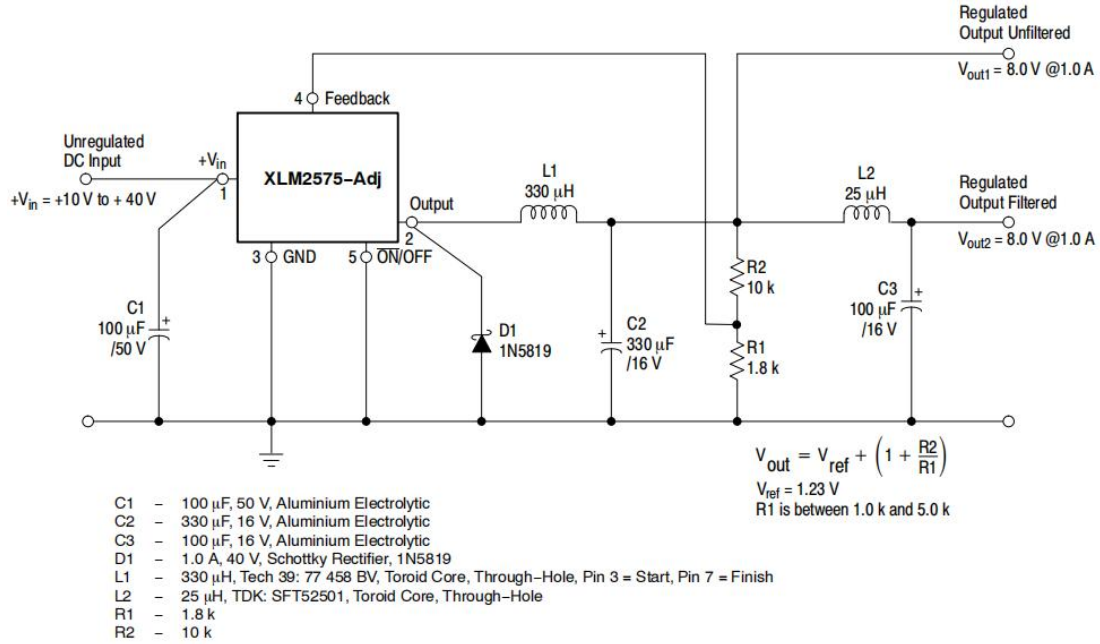
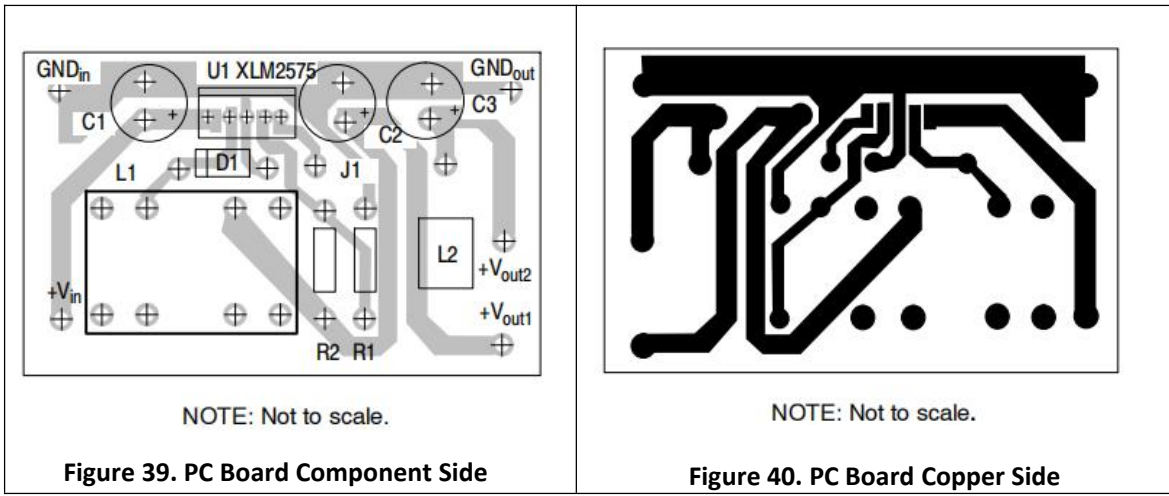

Figure 38. Schematic Diagram of the 8.0 V @ 1.0 V Step-Down Converter Using the XLM2575-Adj
(An additional LC filter is included to achieve low output ripple voltage)



17. ORDERING INFORMATION

Ordering Information

Part Number	Device Making	Package type	Body size (mm)	Temperate (°C)	MSL	Transpo Rt	Package Quantit
XLM2575D2T-3.3R4G	XL2575T-3.3	TO263-5	10.00*8.80	-40 to +85	MSL3	T&R	800
XLM2575D2T-5R4G	XL2575T-5.0	TO263-5	10.00*8.80	-40 to +85	MSL3	T&R	800
XLM2575D2T-12R4G	XL2575T-12	TO263-5	10.00*8.80	-40 to +85	MSL3	T&R	800
XLM2575D2T-ADJR4G	XL2575T-ADJ	TO263-5	10.00*8.80	-40 to +85	MSL3	T&R	800

18. DIMENSIONAL DRAWINGS

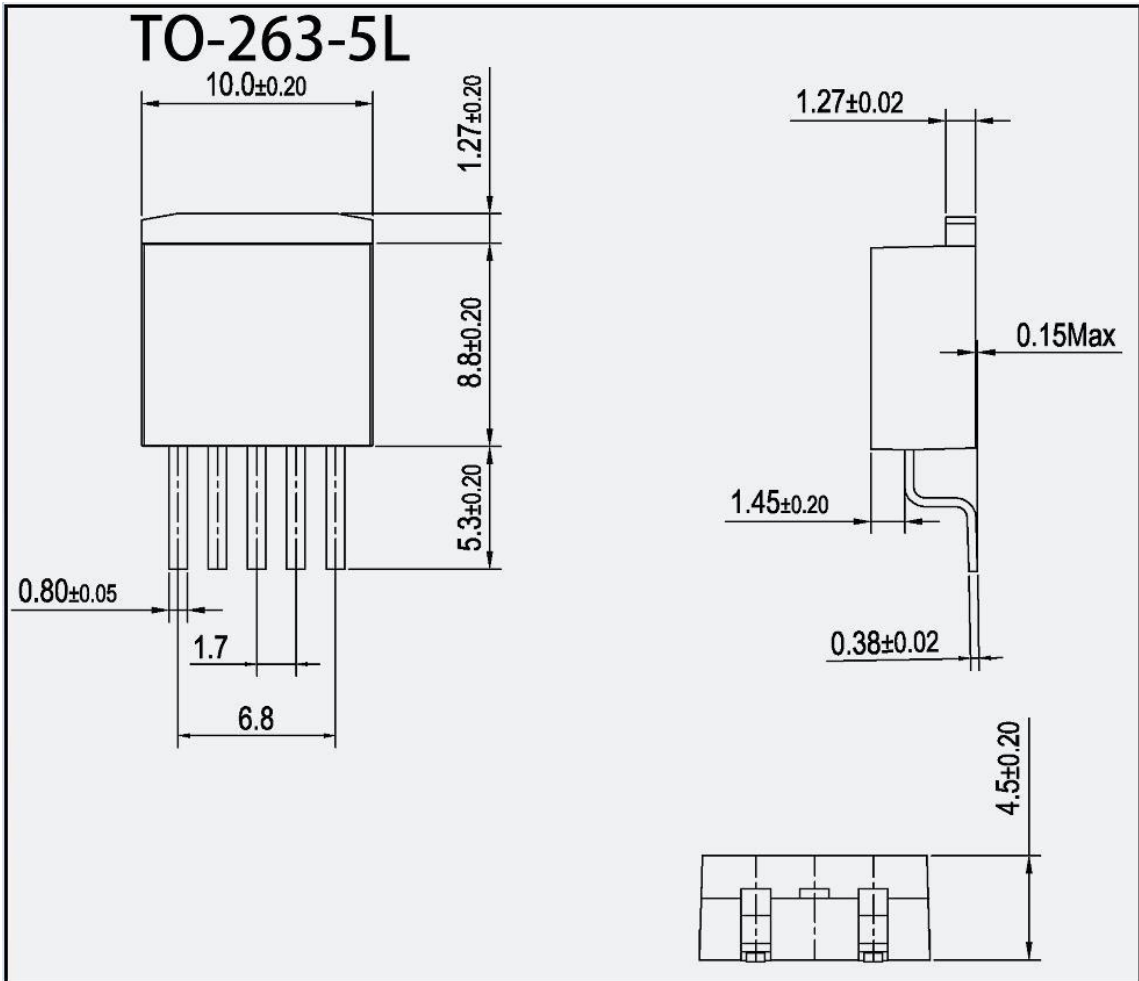

[if you need help contact us. Xinluda reserves the right to change the above information without prior notice.]