

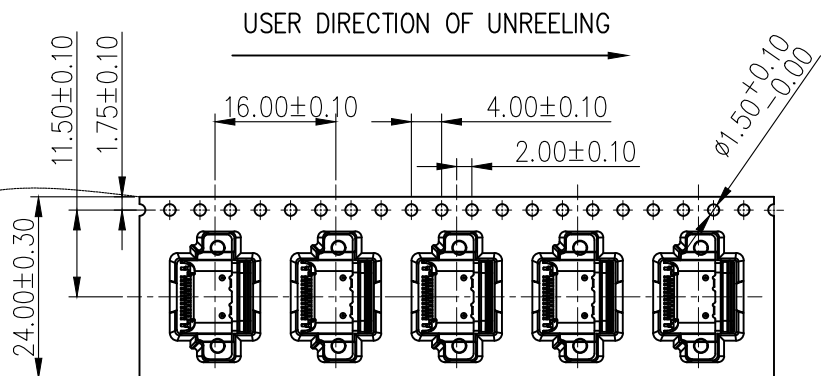

RoHS



COVER TAPE PEELING ANGLE: 165°~180°  
PEELING FORCE: 20~130g

CARRIER TAPE

USER DIRECTION OF UNREELING

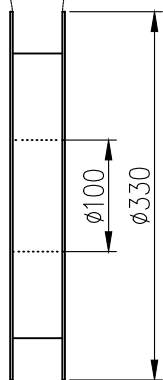

DETAIL B

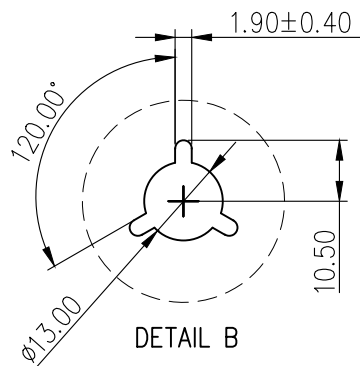

NOTES

1. NUMBER OF CONNECTORS: 900PCS/REEL
2. LEAD TAPE LENGTH

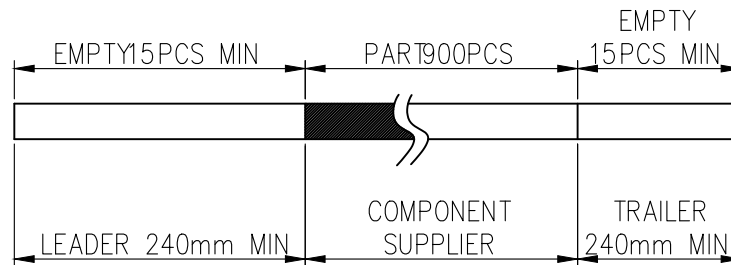

3. QUANTITY: 9000PCS/CARTON

CARTON  
350\*350\*325 K=K

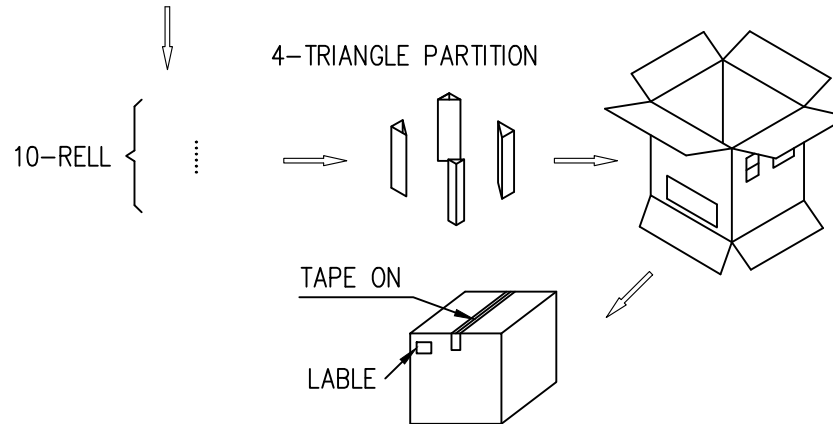

MILLIMETERS	INCH
X.* ±2*	X.* ±2*
.X ±0.30	.X ±0.012
.XX ±0.20	.XX ±0.008
.XXX ±0.10	.XXX ±0.004

THESE DRAWINGS AND SPECIFICATIONS ARE THE PROPERTY OF DongGuan JinBLai Metal Plastic Technology Co.,Ltd  
COPIED OR USED IN ANY MANNER WITHOUT THE PRIOR WRITTEN CONSENT OF DongGuan JinBLai Metal Plastic Technology Co.,Ltd



东莞市金比莱五金塑胶科技有限公司  
DONGGUAN JBL TECH CO., LTD

TITLE	TYPE C 24PIN 双壳沉板 0.88 双排SMT	DR	
PART NO.	104369702	CHKD	
PRO J.	PAGE 2/2	UNITS mm	APPD
SIZE	A4	SCALE 1:1	DIS NO.