

RoHS

REV.	ECN.#	DESCRIPTION	NAME	DATE
A0	_____	NEW RELEASE	HZP	2024.11.23

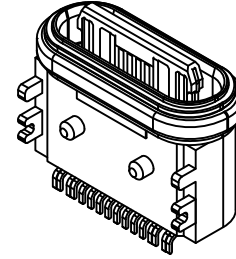
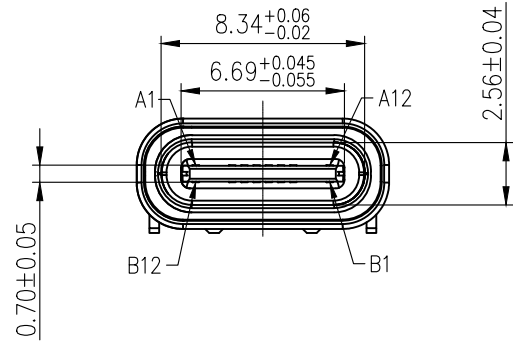

NOTES:

- MATERIAL:
  - HOUSING: PA10T UL94V-0; COLOR: BLACK
  - TERMINAL: C7025
  - SHELL: ZINC ALLOY
  - MID PLATE: SUS301
  - O RING: SILICON RUBBER
- FINISH:
  - TERMINAL: 3U" Au PLATED ON CONTACT AREA; G/F PLATED ON SOLDER AREA; Ni 30u" MIN. UNDERPLATED OVERALL.
  - SHELL: Ni 30u" MIN. PLATED OVERALL
  - MID PLATE: CLEANING.
- ELECTRICAL SPECIFICATION:
  - RATED CURRENT: VBUS AND GND PIN 3.0A; Other pin 0.25A
  - CONTACT RESISTANCE: 40mΩ MAX(INITIAL). 50mΩ MAX (AFTER).
  - INSULATION RESISTANCE: 100MΩ MIN.
  - DIELECTRIC WITHSTANDING VOLTAGE: 100V AC .
- MACHINERY SPECIFICATION:
  - MATING FORCE: 5N~20N. UNMATING FORCE: 8N~20N. (AFTER TEST:6N~20N).
  - DURABILITY: 10000 CYCLES MIN.
- ENVIRONMENTAL SPECIFICATION:
  - OPERATING CONDITION: TEMPERATURE-40°C~+85°C
- WATER PROOFNESS: THIS PRODUCT IS BASED ON IPX7.

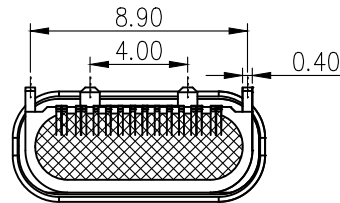
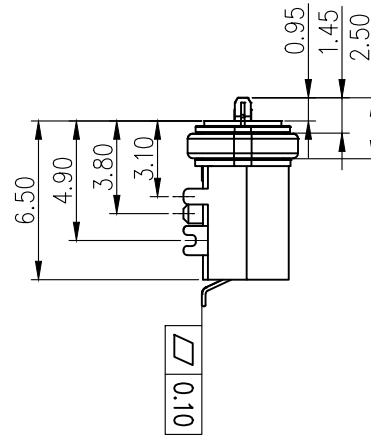
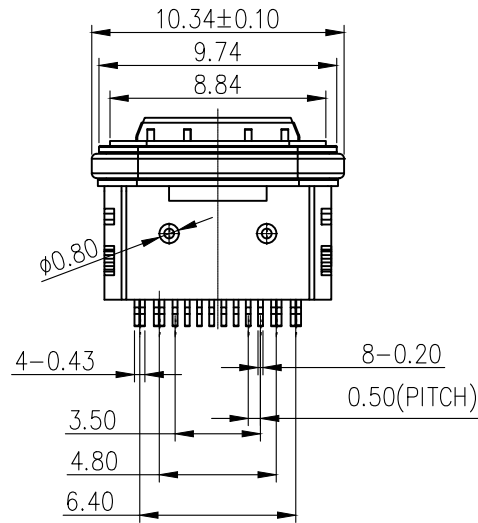
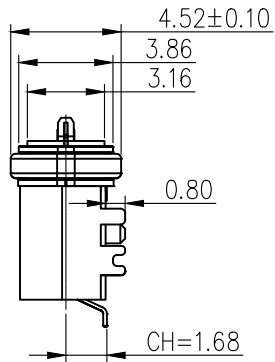

MILLIMETERS	INCH
X.* ±2*	X.* ±2*
.X ±0.30	.X ±0.012
.XX ±0.20	.XX ±0.008
.XXX ±0.10	.XXX ±0.004

THESE DRAWINGS AND SPECIFICATIONS ARE THE PROPERTY OF DongGuan JinBilal Metal Plastic Technology Co.,Ltd COPIED OR USED IN ANY MANNER WITHOUT THE PRIOR WRITTEN CONSENT OF DongGuan JinBilal Metal Plastic Technology Co.,Ltd



东莞市金比莱五金塑胶科技有限公司  
DONGGUAN JBL TECH CO., LTD

TITLE	TYPE C 16Pin CH=1.68 舌片 外径0.95mm 锌合金超薄款母座	DR		
PART NO.	1043212602	CHKD		
PRO J.	PAGE 1/3	UNITS mm	APPD	
SIZE	A4	SCALE 1:1	DIS NO.	

RoHS

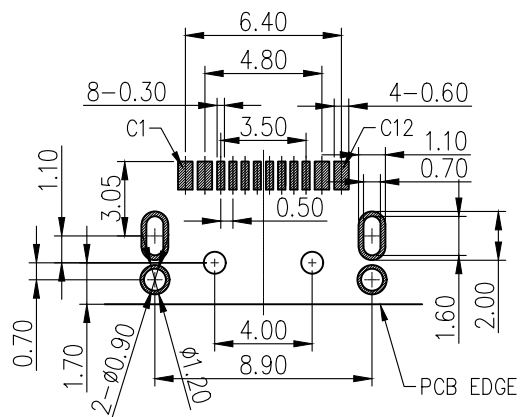

RECOMMENDED PCB LAYOUT(TOP VIEW)

THICKNESS T=0.8mm  
DEFAULT TOLERANCE+/-0.05

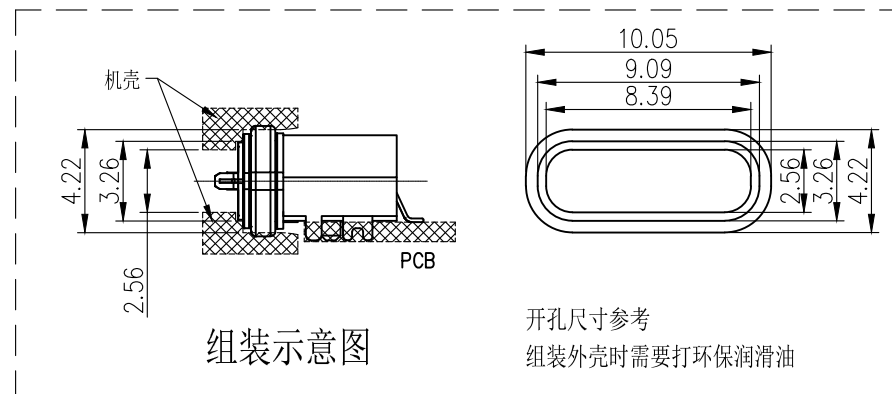

INTERFACE(FRONT VIEW)

A1	A2	A3	A4	A5	A6	A7	A8	A9	A10	A11	A12
GND			VBUS	CC1	DP1	DN1	SBU1	VBUS			GND
GND			VBUS	SBU2	DN2	DP2	CC2	VBUS			GND
B12	B11	B10	B9	B8	B7	B6	B5	B4	B3	B2	B1

PIN ASSIGNMENT

PIN NO.	A1&B12	A4&B9	B8	A5	B7	A6	A7	B6	A8	B5	A9&B4	A12&B1
SINGAL NAME	GND	VBUS	SBU2	CC1	DN2	DP1	DN1	DP2	SBU1	CC2	VBUS	GND
PCB PAD NO.	C1	C2	C3	C4	C5	C6	C7	C8	C9	C10	C11	C12

MILLIMETERS	INCH		 东莞市金比莱五金塑胶科技有限公司 DONGGUAN JBL TECH CO., LTD			
X.* ±2'	X.* ±2'					
.X ±0.30	.X ±0.012					
.XX ±0.20	.XX ±0.008					
.XXX ±0.10	.XXX ±0.004		TITLE TYPE C 16Pin CH=1.68 舌片 外径0.95mm 锌合金超薄款母座 DR			
THESE DRAWINGS AND SPECIFICATIONS ARE THE PROPERTY OF DongGuan JinBiLai Metal Plastic Technology Co.,Ltd COPIED OR USED IN ANY MANNER WITHOUT THE PRIOR WRITTEN CONSENT OF DongGuan JinBiLai Metal Plastic Technology Co.,Ltd			PART NO.	1043212602	CHKD	
			PRO J.	PAGE 2/3	UNITS mm	APPD
			SIZE	A4	SCALE 1:1	DIS NO.
						

RoHS

USER DIRECTION OF UNREELING

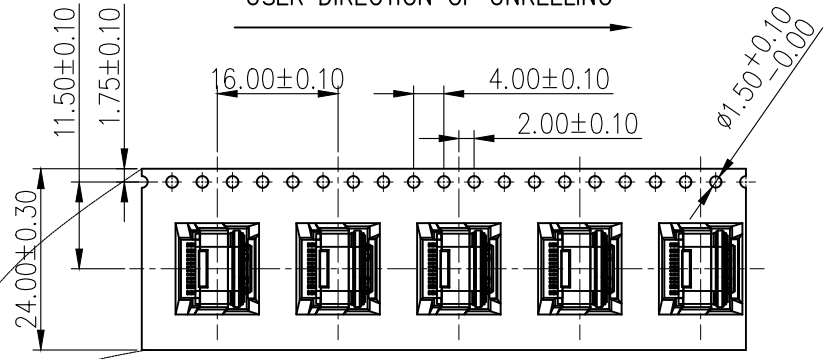

COVER TAPE PEELING ANGLE: 165°~180°  
PEELING FORCE: 20~130g

USER DIRECTION OF UNREELING

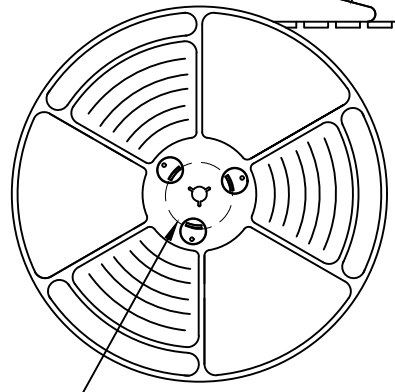

DETAIL B

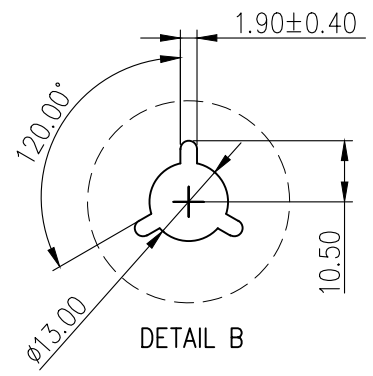

DETAIL B

NOTES

1. NUMBER OF CONNECTORS: 800PCS/REEL
2. LEAD TAPE LENGTH

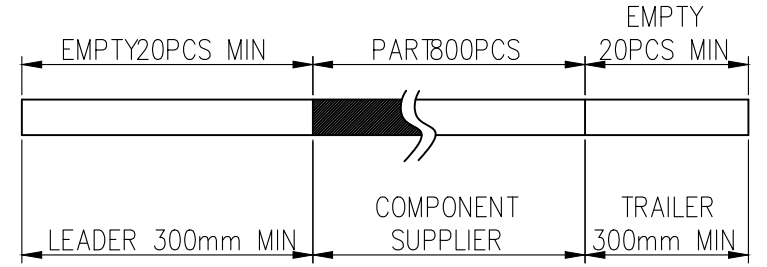

3. QUANTITY: 8000PCS/CARTON

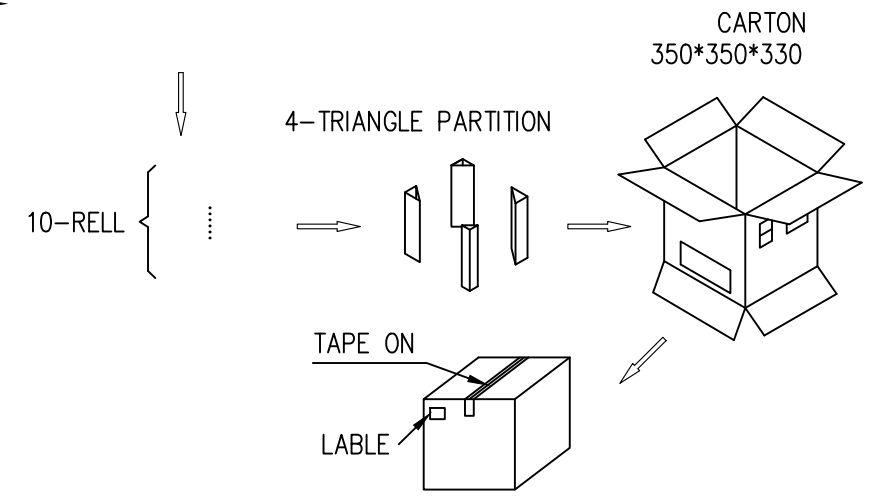

MILLIMETERS	INCH
X.* ±2*	X.* ±2*
.X ±0.30	.X ±0.012
.XX ±0.20	.XX ±0.008
.XXX ±0.10	.XXX ±0.004

THESE DRAWINGS AND SPECIFICATIONS ARE THE PROPERTY OF DongGuan JinBiLai Metal Plastic Technology Co.,Ltd  
COPIED OR USED IN ANY MANNER WITHOUT THE PRIOR WRITTEN CONSENT OF DongGuan JinBiLai Metal Plastic Technology Co.,Ltd



东莞市金比莱五金塑胶科技有限公司  
DONGGUAN JBL TECH CO., LTD

TITLE	TYPE C 16Pin CH=1.68 舌片 外游0.95mm 锌合金超薄款母座	DR	
PART NO.	1043212602	CHKD	
PRO J.	PAGE 3/3 UNITS mm	APPD	
SIZE	A4 SCALE 1:1 DIS NO.		