

RoHS

REV.	ECN.#	DESCRIPTION	NAME	DATE
A0		NEW RELEASE	HZP	2023.01.02

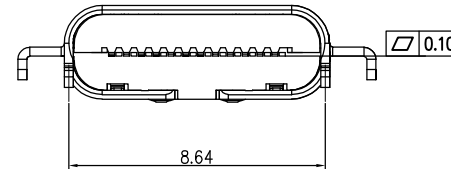

- NOTES:
- MATERIAL:
 - HOUSING: PA9T UL94V-0; COLOR: BLACK
 - TERMINAL: C7025
 - SHELL: SUS304
 - MID PLATE: SUS301
 - EMI PLATE: SUS304
 - FINISH:
 - TERMINAL: G/F PLATED ON CONTACT AREA; G/F PLATED ON SOLDER AREA; Ni 30u" MIN. UNDERPLATED OVERALL.
 - SHELL: Ni 30u" MIN. PLATED OVERALL
 - MID PLATE: CLEANING.
 - EMI PLATE: CLEANING.
 - ELECTRICAL SPECIFICATION:
 - RATED CURRENT: VBUS AND GND PIN 5A; Other pin 0.25A
 - CONTACT RESISTANCE: 40mΩ MAX(INITIAL).
 - INSULATION RESISTANCE: 100MΩ MIN.
 - DIELECTRIC WITHSTANDING VOLTAGE: 100V AC .
 - MACHINERY SPECIFICATION:
 - MATING FORCE: 5N~20N. UNMATING FORCE: 8N~20N. (AFTER TEST:6N~20N).
 - DURABILITY: 10000 CYCLES MIN.
 - ENVIRONMENTAL SPECIFICATION:
 - OPERATING CONDITION: TEMPERATURE-25°C~+85°C; HUMIDITY 80% R.H MAX
 - SOLDER ABILITY: 245±5°C, 5±0.5s
 - IR REFLOW: THE PEAK TEMPERATURE ON THE BOARD SHALL BE MAINTAINED FOR 10 SECONDS AT 260°C.

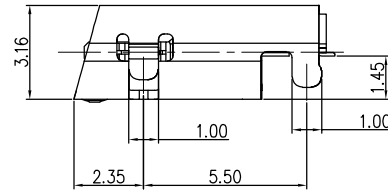
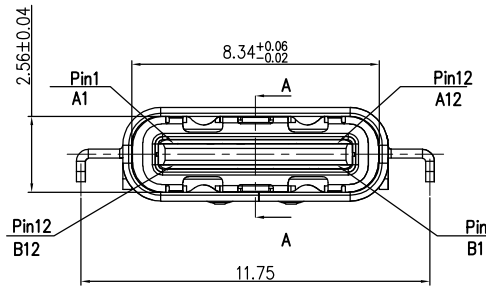
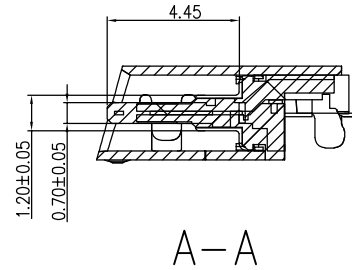
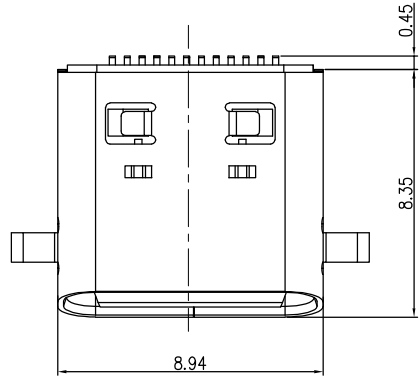
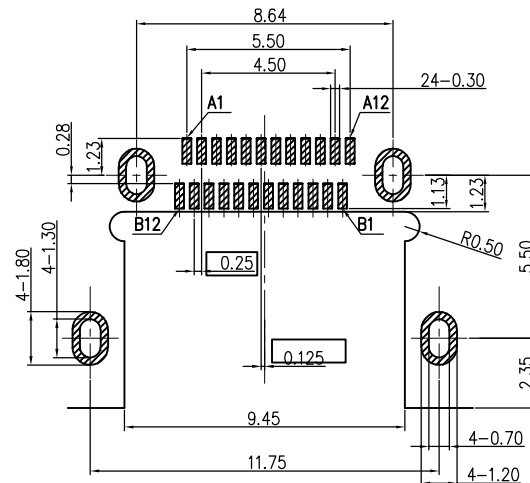
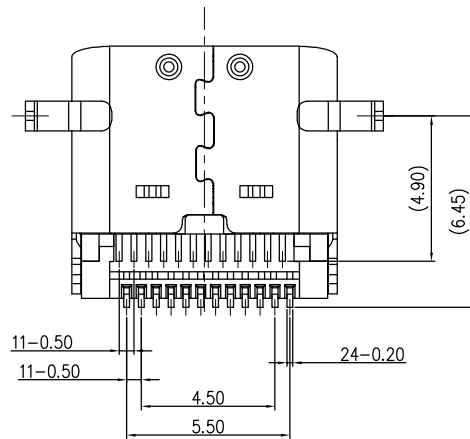

RECOMMENDED P.C.B. LAYOUT
TOLERANCE UNSPECIFIED ±0.05mm

PIN ASSIGNMENTS:

PIN No.	A1	A2	A3	A4	A5	A6	A7	A8	A9	A10	A11	A12
SIGNAL NAME	GND	TX1+	TX1-	Vbus	CC1	D+	D-	SBU1	Vbus	RX2-	RX2+	GND
PIN No.	B12	B11	B10	B9	B8	B7	B6	B5	B4	B3	B2	B1
SIGNAL NAME	GND	RX1+	RX1-	Vbus	SUB2	D-	D+	CC2	Vbus	TX2-	TX2+	GND

MILLIMETERS	INCH
X.* ±2*	X.* ±2*
X ±0.30	.X ±0.012
XX ±0.20	.XX ±0.008
XXX ±0.10	.XXX ±0.004

THESE DRAWINGS AND SPECIFICATIONS ARE THE PROPERTY OF DongGuan JinBiLai Metal Plastic Technology Co.,Ltd
COPIED OR USED IN ANY MANNER WITHOUT THE PRIOR WRITTEN CONSENT OF DongGuan JinBiLai Metal Plastic Technology Co.,Ltd



东莞市金比莱五金塑胶科技有限公司
DONGGUAN JBL TECH CO., LTD

TITLE	TYPE C 24P 双排沉板1.5 L8.35双排SMT 斜口	DR	
PART NO.	1044114142	CHKD	
PRO J.	PAGE 1/2 UNITS mm	APPD	
SIZE	A4 SCALE 1:1 DIS NO.		

RoHS

USER DIRECTION OF UNREELING

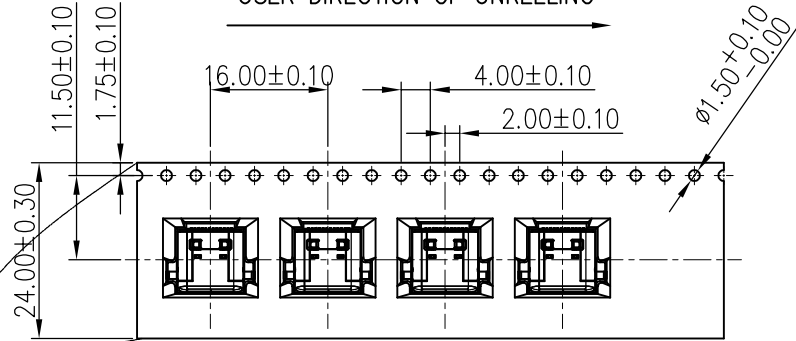

COVER TAPE PEELING ANGLE: 165°~180°

PEELING FORCE: 20~130g

CARRIER TAPE

USER DIRECTION OF UNREELING

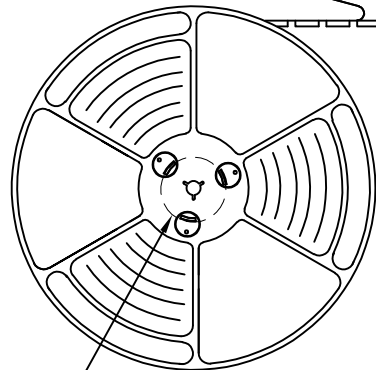

DETAIL B

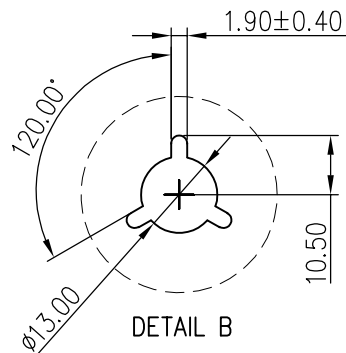

DETAIL B

NOTES

1. NUMBER OF CONNECTORS: 1000PCS/REEL
2. LEAD TAPE LENGTH

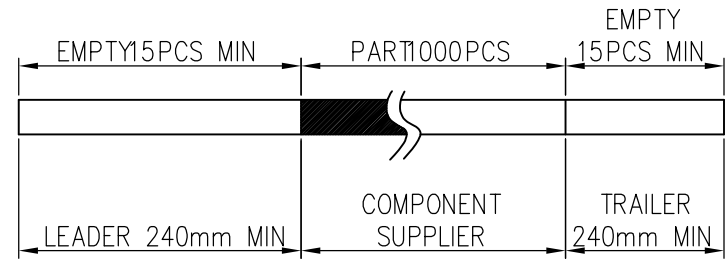

3. QUANTITY: 10000PCS/CARTON

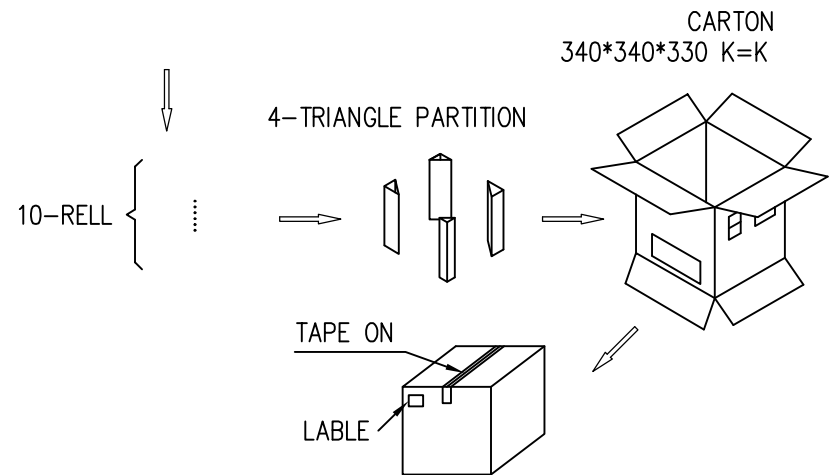

MILLIMETERS		INCH		东莞市金比莱五金塑胶科技有限公司 DONGGUAN JBL TECH CO., LTD						
X.* ±2*		X.* ±2*		TITLE		TYPE C 24P 双排沉板1.5 L8.35双排SMT 斜口		DR		
X ±0.30		.X ±0.012		PART NO.		1044114142		CHKD		
XX ±0.20		.XX ±0.008		PRO J.		PAGE	2/2	UNITS	mm	APPD
XXX ±0.10		.XXX ±0.004		SIZE		A4	SCALE	1:1	DIS NO.	
THESE DRAWINGS AND SPECIFICATIONS ARE THE PROPERTY OF DongGuan JinBiLai Metal Plastic Technology Co.,Ltd COPIED OR USED IN ANY MANNER WITHOUT THE PRIOR WRITTEN CONSENT OF DongGuan JinBiLai Metal Plastic Technology Co.,Ltd										