

ROHS

REV.	ECN NO.	DESCRIPTION	DRAW	DATE

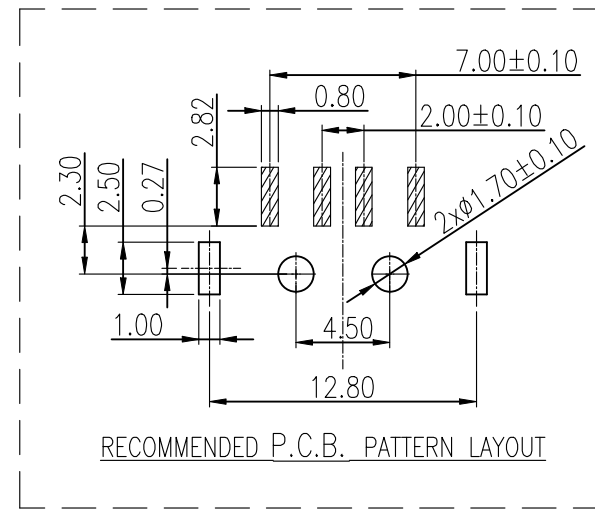
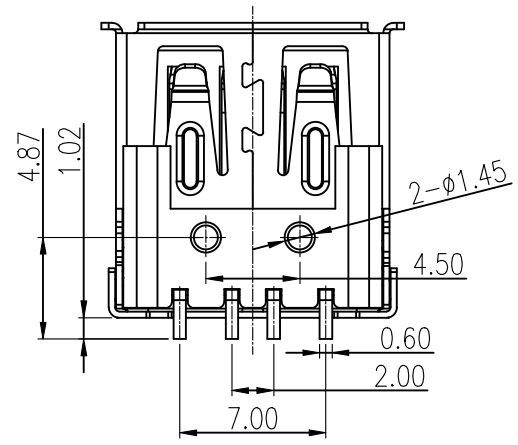
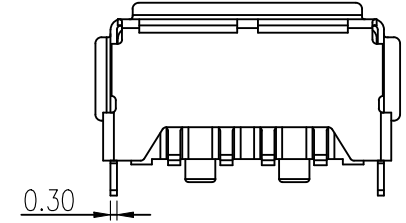
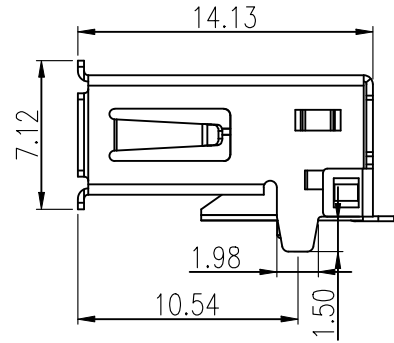
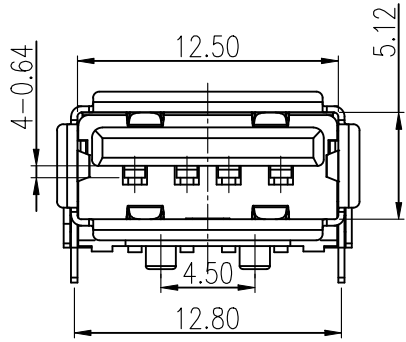
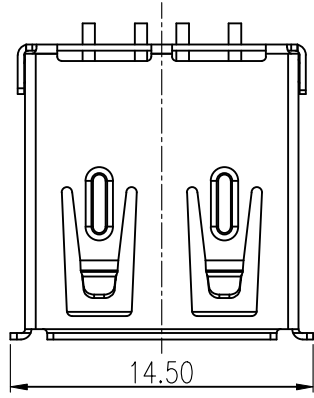

- NOTES:
- MECHANICAL:
 - MATING: 35N MAX.
 - WITHDRAWAL: 10N MIN(SUS)
 - DURABILITY: 10000 CYCLES MIN.
 - ELECTRICAL:
 - CURRENT: 1.5A MAX
 - VOLTAGE: 30V MAX
 - WITHSTANDING VOLTAGE: 500V AC
 - CONTACT RESISTANCE: 30 mΩ MAX
 - INSULATION RESISTANCE: 1000MΩ MIN
 - ENVIRONMENTAL
 - TEMPERATURE RANGE -55°C ~ +85°C
 - PRODUCT MEET FOR ROHS STANDARD

ITEM	PART NAME	Q'TY	Material
1	SHELL	1	SUS304R-1/2H,Ni40u"min
2	CONTACT	1	钛铜,G/F 镍50u"min,雾锡120u"min
3	HOUSING	1	LCP(无卤)

CUSTOMER DRAWING		LAILIAN 深圳市莱联电子有限公司	
DRAWING		SHENZHEN LAILIAN ELECTRONICS CO., LTD	
CHECKED		TITLE	USB AF SMT+DIP 卷边带柱(4PIN) REV. A
APPROVED		PART NO.	LAIL-USB-TYPE-A-4PIN-03-WT UNITS mm
TOLERANCES ARE		DWG. NO.	Projection
30-150	±0.35		
10-30	±0.2		
5-10	±0.15		
0-5	±0.1		