

# MSKSEMI 美森科

SEMICONDUCTOR



ESD



TVS



TSS



MOV



GDT



PLED

## AP3031KTR-MS

Product specification

**GENERAL DESCRIPTION**

The AP3031KTR-MS is a step-up converter designed for driving up to 7 series white LEDs from a single cell Lithium Ion battery. The AP3031 uses current mode, fixed frequency architecture to regulate an LED current, which is measured through an external current sense resistor. Its low 200mV feedback voltage reduces power loss and improves efficiency.

The AP3031KTR-MS includes under-voltage lockout, current limiting and thermal overload protection preventing damage in the event of an output overload. Optimized operation frequency can meet the requirement of small LC filters value and low operation current with high efficiency. Internal soft start function can reduce the inrush current. Tiny package type provides the best solution for PCB space saving and total BOM cost.



**FEATURES**

- High Efficiency: Up to 90%
- 1.2MHz Constant Frequency Operation
- Integrated internal Power MOSFET
- Drives up to 7 Series WLEDs
- Low 200mV Feedback Voltage
- Soft-start/Dimming with wide Frequency Range
- UVLO, Thermal Shutdown
- Internal Current limit
- Over Voltage Protection
- Small LC Filter
- Minimize the External Component
- <1µA Shutdown Current
- SOT23-6 Package

**APPLICATIONS**

- Camera Flash White LED
- Mobile Phone, Smart Phone LED Backlight
- PDA LED Backlight
- Digital Still Cameras
- Camcorder

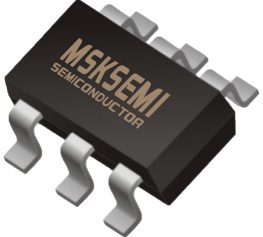
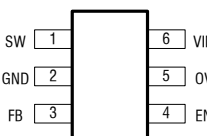
**Reference News**

| SOT23-6   | PIN DESCRIPTION   | MARKING   |
|---|---|---|
|  | <p style="text-align: center;">TOP VIEW</p>  <p style="text-align: center;">6-LEAD PLASTIC SOT-23<br/>T<sub>JMAX</sub> = 160°C, θ<sub>JA</sub> = 250°C/W, θ<sub>JC</sub> = 130°C/W</p> |  |

**TYPICAL APPLICATION**

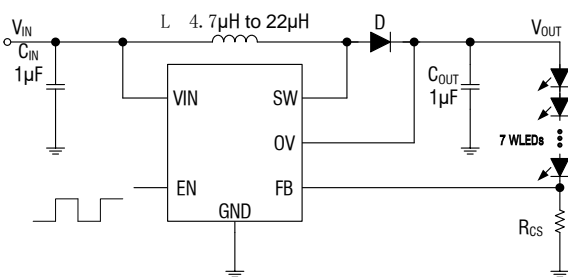
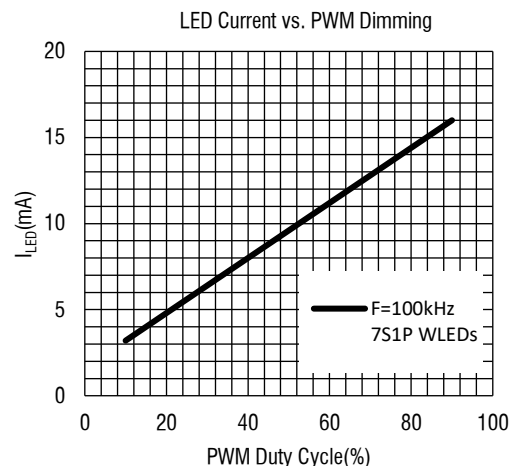

Figure 1. Basic Application Circuit



**PIN DESCRIPTION**

| Pin Name | Pin Number | Description   |
|----------|------------|---|
| SW       | 1          | Inductor Connection. Connect to the switched side of the external inductor as well as the anode of the external diode. SW is high impedance during shutdown.                                      |
| GND      | 2          | Ground Pin.   |
| FB       | 3          | Current-Sense Feedback Input. Connect a resistor from FB to GND to set the LED current: $I_{LED} = 0.2V/R_{CS}$   |
| EN       | 4          | Enable and LED Brightness Control Input. Pull high to turn on IC. Drive EN with a 20kHz to 1MHz unfiltered PWM dimming signal for DC LED current that is proportional to the signal's duty cycle. |
| OV       | 5          | Over Voltage Input. The AP3031KTR-MS turn off the N-channel MOSFET when $V_{out}$ exceeds 28V. Connect OV to the output at the top of the LED string.   |
| VIN      | 6          | Power Supply Input. Must be closely decoupled to GND with a 1μF or greater ceramic capacitor.   |

**ABSOLUTE MAXIMUM RATINGS** (Note 1)

Input Supply Voltage.....-0.3V to 25V  
 EN,FB Voltages.....-0.3V to 6V  
 SW Voltage.....-0.3V to 30V  
 Power Dissipation.....0.6W  
 Thermal Resistance  $\theta_{JC}$ .....130°C/W  
 Thermal Resistance  $\theta_{JA}$ .....250°C/W

Junction Temperature(Note2).....160°C  
 Operating Temperature Range.....-40°C to 85°C  
 Lead Temperature(Soldering,10s).....300°C  
 Storage Temperature Range.....-65°C to 150°C  
 ESD HBM(Human Body Mode).....2kV  
 ESD MM(Machine Mode).....200V

**ELECTRICAL CHARACTERISTICS (Note 3)**

 ( $V_{IN}=V_{EN}=3.7V, T_A = 25^{\circ}C$ , unless otherwise noted.)

| PARAMETER                        | CONDITIONS                                | MIN | TYP        | MAX       | UNIT     |
|----------------------------------|---|-----|------------|-----------|----------|
| Operating Input Voltage          |   | 3   |            | 24        | V        |
| Under Voltage Lockout            |   |     |            | 2.6       | V        |
| Under Voltage Lockout Hysteresis |   |     | 100        |           | mV       |
| Current (Shutdown)               | $V_{EN} < 0.4V$                           |     |            | 1         | $\mu A$  |
| Quiescent Current                | $V_{FB} = 0.15V$ , No switching           |     | 200        |           | $\mu A$  |
| Supply Current                   | $V_{FB} = 0V$ , switching                 |     | 0.6        | 1         | mA       |
| Regulated Feedback Voltage       |   | 194 | 200        | 206       | mV       |
| Switching Frequency              |   |     | 1.2        |           | MHz      |
| ON Resistance of NMOS            |   |     | 0.1        |           | $\Omega$ |
| Peak Current Limit               | $V_{IN} = 4.2V, \text{Duty cycle} = 50\%$ | 2   |            |           | A        |
| EN Shutdown Voltage              |   |     |            | 0.4       | V        |
| EN Enable Voltage                |   | 1.5 |            |           | V        |
| EN Leakage Current               |   |     | $\pm 0.01$ | $\pm 1.0$ | $\mu A$  |
| OVP Threshold                    | Open LED, $V_{OUT}$ Rising                |     | 28         |           | V        |

**Note 1:** Absolute Maximum Ratings are those values beyond which the life of a device may be impaired.

**Note 2:**  $T_J$  is calculated from the ambient temperature  $T_A$  and power dissipation  $P_D$  according to the following formula:  $T_J = T_A + (P_D) \times (250^{\circ}C/W)$ .

**Note 3:** 100% production test at  $25^{\circ}C$ . Specifications over the temperature range are guaranteed by design and characterization.

**TYPICAL PERFORMANCE CHARACTERISTICS**

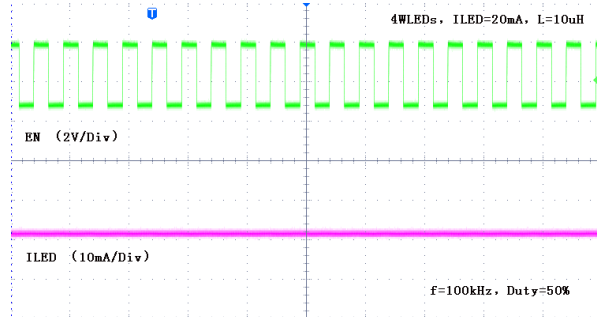
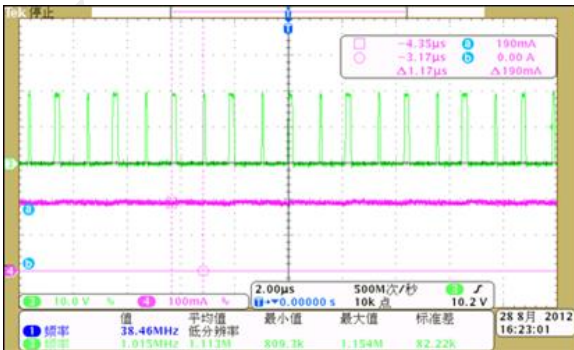
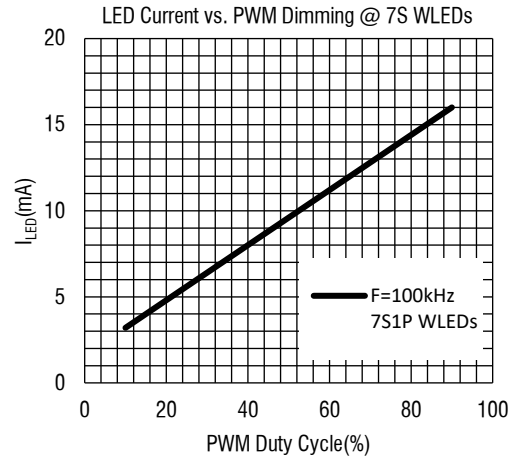
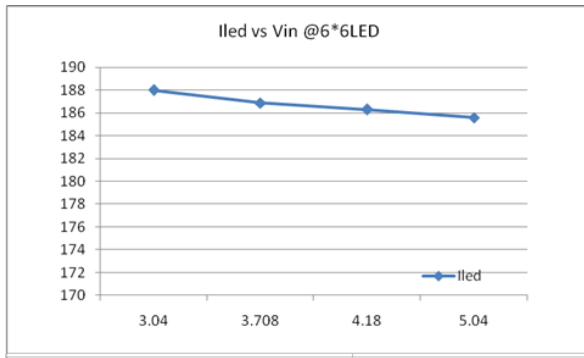
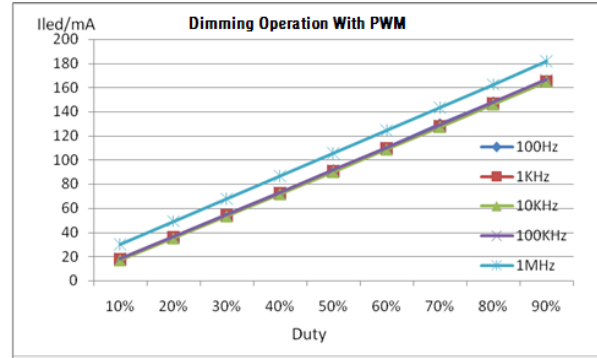
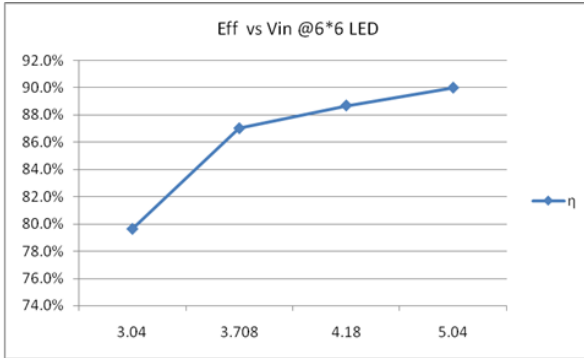

Normal Operation @  $V_{IN}=3.0V$

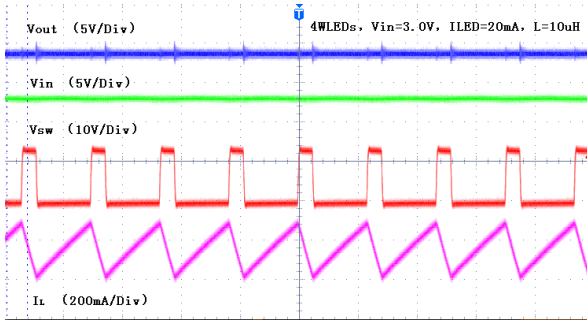

Normal Operation @  $V_{IN}=3.7V$

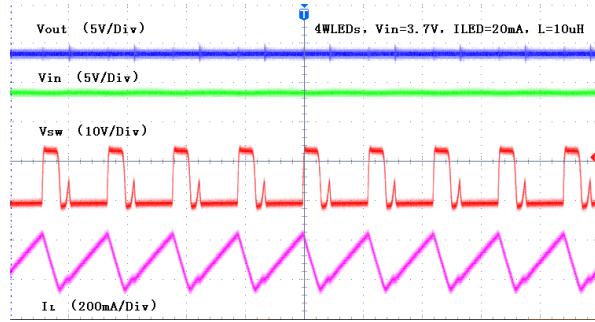

Normal Operation @  $V_{IN}=4.3V$

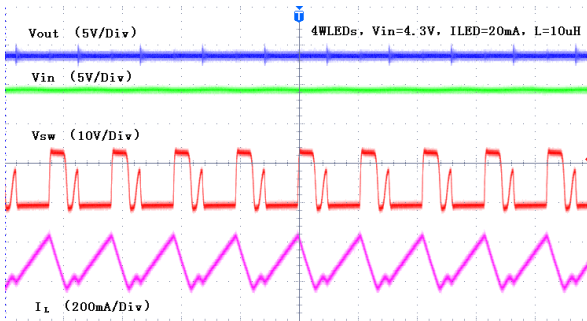

Normal Operation @  $V_{IN}=5.5V$

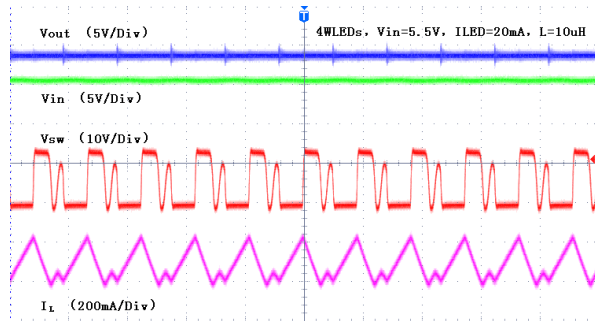

**FUNCTIONAL BLOCK DIAGRAM**

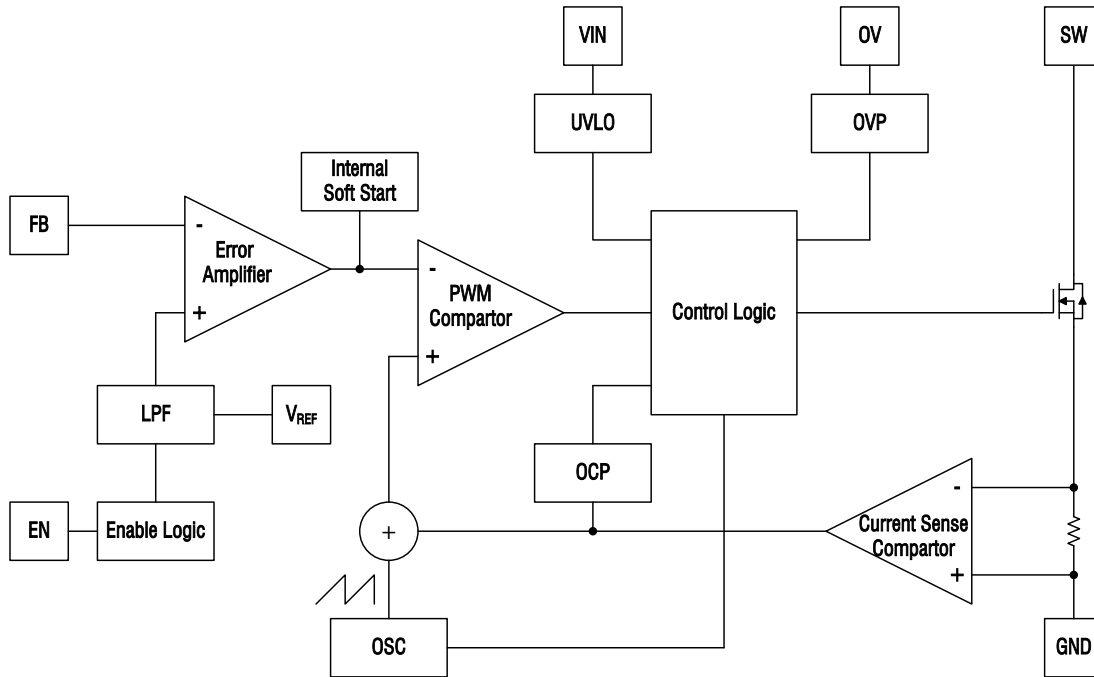

Figure 2. AP3031KTR-MS Block Diagram

**FUNCTIONAL DESCRIPTION**

The AP3031KTR-MS uses a constant frequency, peak current mode boost regulator architecture to regulate the series string of white LEDs. At the start of each oscillator cycle the FET is turned on through the control circuitry.

To prevent sub-harmonic oscillations at duty cycles greater than 50 percent, a stabilizing ramp is added to the output of the current sense amplifier and the result is fed into the positive input of the PWM comparator.

When this voltage equals the output voltage of the error amplifier the power FET is turned off. The voltage at the output of the error amplifier is

an amplified version of the difference between the 200mV reference voltage and the feedback voltage. In this way the peak current level keeps the output in regulation. If the feedback voltage starts to drop, the output of the error amplifier increases. This results in more current flowing through the power FET, thus increasing the power delivered to the output.

## APPLICATIONS INFORMATION

### Adjusting LED Current

Set the maximum LED current using a resistor from FB to GND. Calculate the resistance as follows:

$$R_{CS} = \frac{200\text{mV}}{I_{LED}}$$

where  $I_{LED}$  is the desired maximum current through the LEDs.

| $I_{LED}(\text{mA})$ | $R_{CS}(\Omega)$ |
|----------------------|------------------|
| 1                    | 200              |
| 5                    | 40               |
| 10                   | 20               |
| 15                   | 13.3             |
| 20                   | 10               |

### LED Dimming Control

- Using a PWM Signal to EN Pin

For controlling the LED brightness, the AP3031 KTR-MS can perform the dimming control by applying a PWM signal to EN pin. The internal soft start and the wide range dimming frequency can eliminate inrush current and audio noise when dimming. The average LED current is proportional to the PWM signal duty cycle. The magnitude of the PWM signal should be higher than the maximum enable voltage of EN pin, in order to let the dimming control perform correctly for preventing the flicker issue, the suggested PWM frequency is  $\geq 20\text{kHz}$  and  $\leq 1\text{MHz}$ .

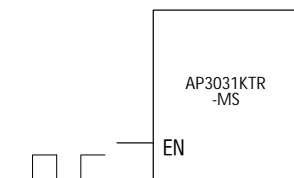

Figure 3

- Using a DC Voltage

Using a variable DC voltage to adjust the brightness is a popular method in some applications. According to the Superposition Theorem, as the DC voltage increases, the voltage contributed to  $V_{FB}$  increases and the voltage drop on R1 decreases, i.e. the LED current decreases. For example, if the  $V_{DC}$  range is from 0V to 2.8V, the selection of resistors sets dimming control of LED current from 20mA to 0mA. The LED current can be calculated by the following equation:

$$I_{LED} = \frac{V_{FB} - \frac{R1 \times (V_{DC} - V_{FB})}{R2}}{R_{CS}}$$

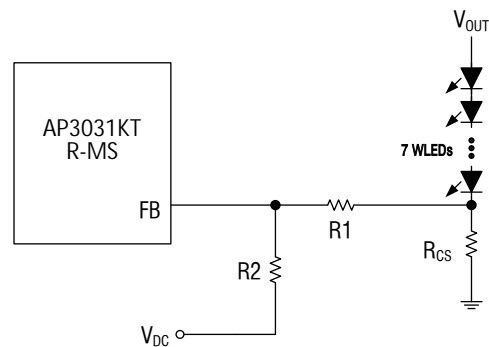

Figure 4

- Using a Filtered PWM signal

Another common application is using a filtered PWM signal as an adjustable DC voltage for LED dimming control. A filtered PWM signal acts as the DC voltage to regulate the output current. The recommended application circuit is shown in the Figure 5. In this circuit, the output ripple depends on the frequency of PWM signal. For smaller output voltage ripple ( $< 100\text{mV}$ ), the recommended frequency of 2.8V PWM signal should be above 20kHz. To fix the frequency of PWM signal and change the duty cycle of PWM signal can get different output current. Figure 5.

shows the relationship between LED current and PWM duty cycle. The LED current can be calculated by the following equation:

$$I_{LED} = \frac{V_{FB} - \frac{R1 \times (V_{PWM} \times Duty - V_{FB})}{R3 + R2}}{R_{CS}}$$

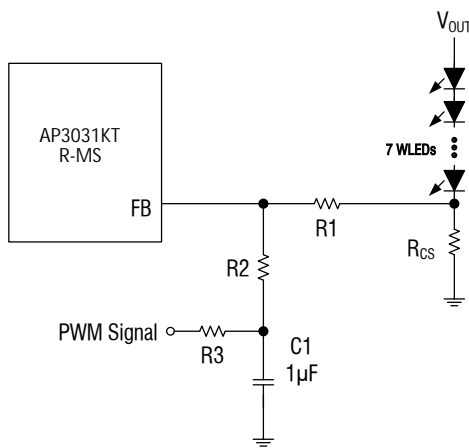

Figure5

**Inductor Selection**

The recommended value of inductor are 4.7 to 22µH. Small size and better efficiency are the major concerns for portable device, such as AP3031KTR-MS used for mobile phone. The inductor should have low core loss at 1.2MHz and low DCR for better efficiency. To avoid inductor saturation current rating should be considered.

**Capacitor Selection**

Input and output ceramic capacitors of 4.7µF are recommended for AP3031KTR-MS applications. For better voltage filtering, ceramic capacitors with low ESR are recommended. X5R and X7R types are suitable because of their wider voltage and temperature ranges.

**Diode Selection**

Schottky diode is a good choice for AP3031KTR-MS because of its low forward voltage drop and fast reverse recovery. Using Schottky diode can get better efficiency. The high speed rectification is

also a good characteristic of Schottky diode for high switching frequency. Current rating of the diode must meet the root mean square of the peak current and output average current multiplication as following :

$$I_D(RMS) = \sqrt{I_{OUT} \times I_{PEAK}}$$

The diode’s reverse breakdown voltage should be larger than the output voltage.

**Layout Consideration**

For best performance of the AP3031KTR-MS, the following guidelines must be strictly followed.

- Input and Output capacitors should be placed close to the IC and connected to ground plane to reduce noise coupling.
- The GND should be connected to a strong ground plane for heat sinking and noise protection.
- Keep the main current traces as possible as short and wide.
- SW node of DC-DC converter is with high frequency voltage swing. It should be kept at a small area.
- Place the feedback components as close as possible to the IC and keep away from the noisy device

**PACKAGE DESCRIPTION**

**SOT23-6**

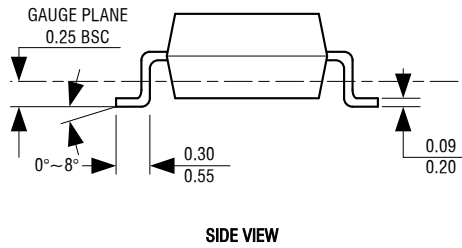
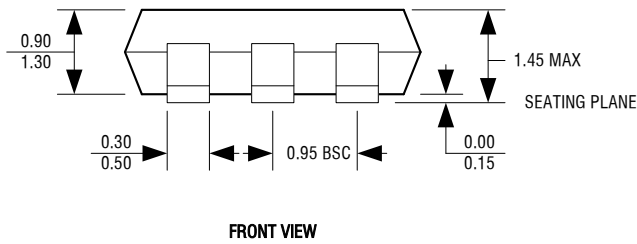
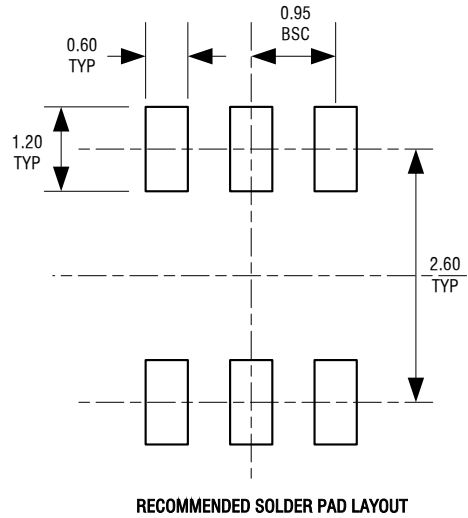
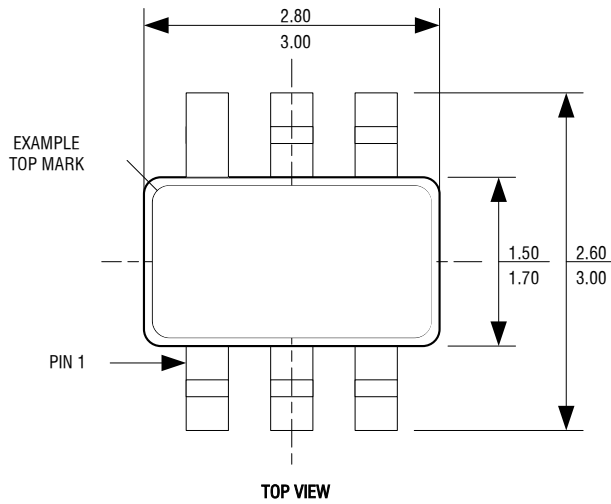

- NOTE:**
- 1.DIMENSIONS ARE IN MILLIMETERS.
  - 2.DRAWING NOT TO SCALE.
  - 3.DIMENSIONS ARE INCLUSIVE OF PLATING.
  - 4.DIMENSIONS ARE EXCLUSIVE OF MOLD FLASH AND METAL BURR.

**Order information**

| Orderable Device | Package  | Packing Option |
|------------------|----------|----------------|
| AP3031KTR-MS     | SOT-23-6 | 3000PCS        |

## Attention

- Any and all MSKSEMI Semiconductor products described or contained herein do not have specifications that can handle applications that require extremely high levels of reliability, such as life-support systems, aircraft's control systems, or other applications whose failure can be reasonably expected to result in serious physical and/or material damage. Consult with your MSKSEMI Semiconductor representative nearest you before using any MSKSEMI Semiconductor products described or contained herein in such applications.
- MSKSEMI Semiconductor assumes no responsibility for equipment failures that result from using products at values that exceed, even momentarily, rated values (such as maximum ratings, operating condition ranges, or other parameters) listed in products specifications of any and all MSKSEMI Semiconductor products described or contained herein.
- Specifications of any and all MSKSEMI Semiconductor products described or contained herein stipulate the performance, characteristics, and functions of the described products in the independent state, and are not guarantees of the performance, characteristics, and functions of the described products as mounted in the customer's products or equipment. To verify symptoms and states that cannot be evaluated in an independent device, the customer should always evaluate and test devices mounted in the customer's products or equipment.
- MSKSEMI Semiconductor strives to supply high-quality high-reliability products. However, any and all semiconductor products fail with some probability. It is possible that these probabilistic failures could give rise to accidents or events that could endanger human lives, that could give rise to smoke or fire, or that could cause damage to other property. When designing equipment, adopt safety measures so that these kinds of accidents or events cannot occur. Such measures include but are not limited to protective circuits and error prevention circuits for safe design, redundant design, and structural design.
- In the event that any or all MSKSEMI Semiconductor products (including technical data, services) described or contained herein are controlled under any of applicable local export control laws and regulations, such products must not be exported without obtaining the export license from the authorities concerned in accordance with the above law.
- No part of this publication may be reproduced or transmitted in any form or by any means, electronic or mechanical, including photocopying and recording, or any information storage or retrieval system, or otherwise, without the prior written permission of MSKSEMI Semiconductor.
- Information (including circuit diagrams and circuit parameters) herein is for example only ; it is not guaranteed for volume production. MSKSEMI Semiconductor believes information herein is accurate and reliable, but no guarantees are made or implied regarding its use or any infringement of intellectual property rights or other rights of third parties.
- Any and all information described or contained herein are subject to change without notice due to product/technology improvement, etc. When designing equipment, refer to the "Delivery Specification" for the MSKSEMI Semiconductor product that you intend to use.