

## FEATURES

- \* For surface mount application
- \* Built-in strain relief
- \* Excellent clamping capability
- \* Low profile package
- \* Fast response time: Typically less than 1.0ps from 0 volt to BV min.
- \* Typical  $I_R$  less than 1 A above 10V
- \* High temperature soldering guaranteed: 260°C / 10 seconds at terminals

## MECHANICAL DATA

- \* Case: Molded plastic
- \* Epoxy: UL 94V-0 rate flame retardant
- \* Lead: Solderable per MIL-STD-202, method 208 guaranteed
- \* Polarity: Color band denotes cathode end except Bidirectional
- \* Mounting position: Any
- \* Weight: 0.063 grams



- "GK" represents the brand name
- "XXX" represents the periodic code
- "YY" represents the product type marking

## VOLTAGE RANGE

180 Volts  
400 Watts Peak Power

## MAXIMUM RATINGS AND ELECTRICAL CHARACTERISTICS

Rating 25°C ambient temperature unless otherwise specified.  
Single phase half wave, 60Hz, resistive or inductive load.  
For capacitive load, derate current by 20%.

RATINGS	SYMBOL	VALUE	UNITS
Peak Power Dissipation at $T_A=25^\circ\text{C}$ , $T_P=1\text{ms}$ (NOTE 1)	$P_{PK}$	Minimum 400	Watts
Peak Forward Surge Current at 8.3ms Single Half Sine-Wave superimposed on rated load (JEDEC method) (NOTE 3)	$I_{FSM}$	60	Amps
Operating and Storage Temperature Range	$T_J, T_{STG}$	-55 to +150	°C

### NOTES:

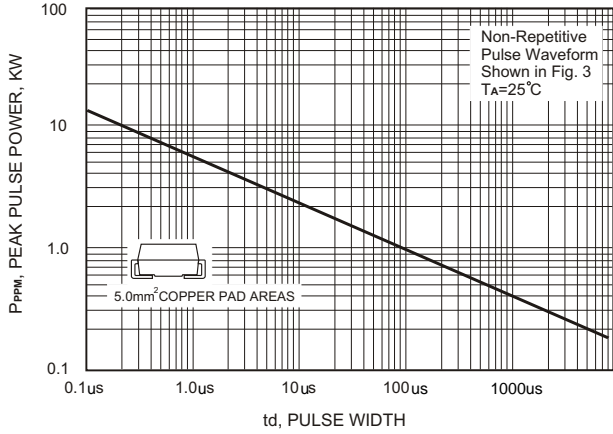
1. Non-repetitive current pulse per Fig. 3 and derated above  $T_A=25^\circ\text{C}$  per Fig. 2.
2. Mounted on Copper Pad area of  $5.0\text{mm}^2$  (.013mm Thick) to each terminal.
3. 8.3ms single half sine-wave, duty cycle = 4 pulses per minute maximum.

## DEVICES FOR BIDIRECTIONAL APPLICATIONS

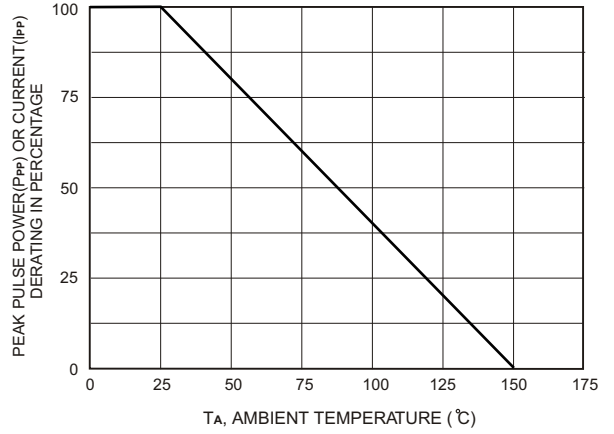
- 1. For bi-directional use C suffix for Types .
- 2. Electrical characteristics apply in both directions.

**RATING AND CHARACTERISTIC CURVES**

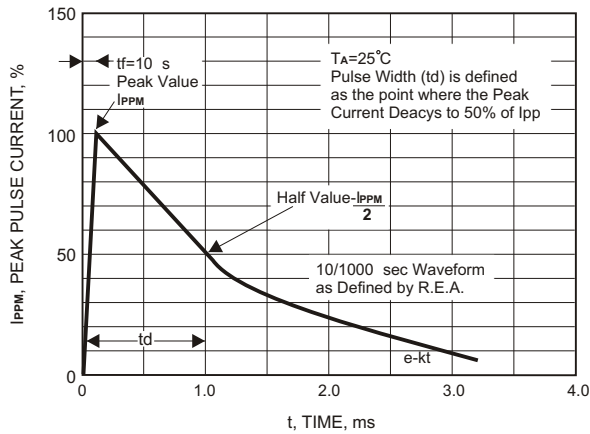
**FIG.1-PEAK PULSE POWER DERATING CURVE**



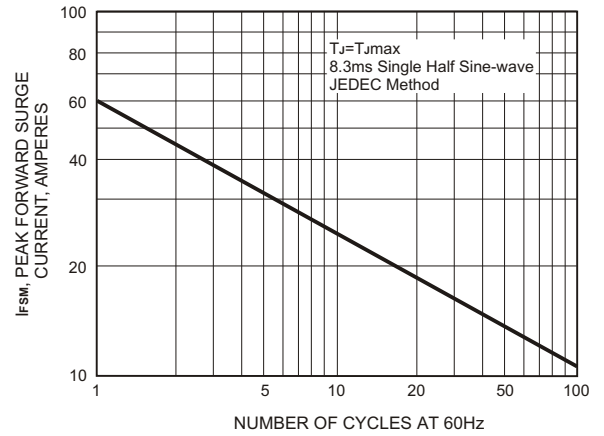
**FIG.2-PULSE DERATING CURVE**



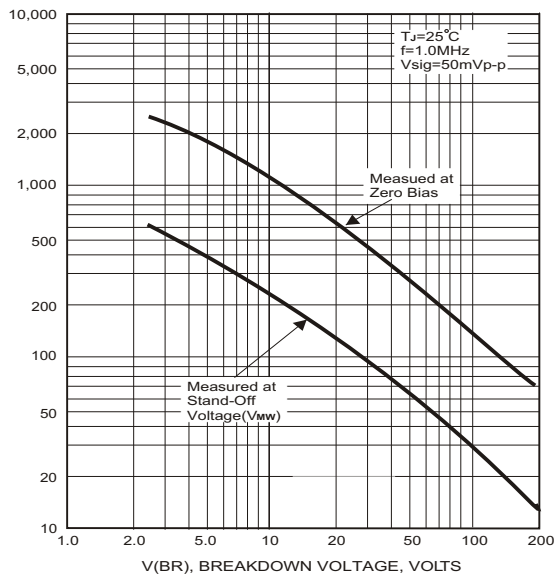
**FIG.3-PULSE WAVE FORM**



**FIG.4 MAXIMUM NON REPETITIVE PEAK FORWARD SURGE CURRENT**

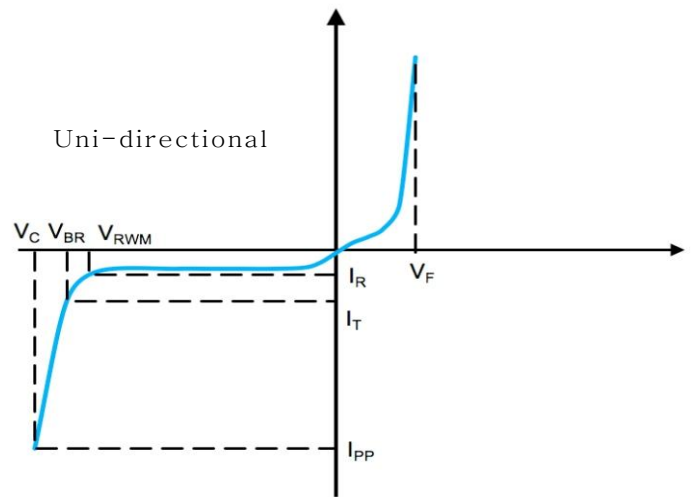
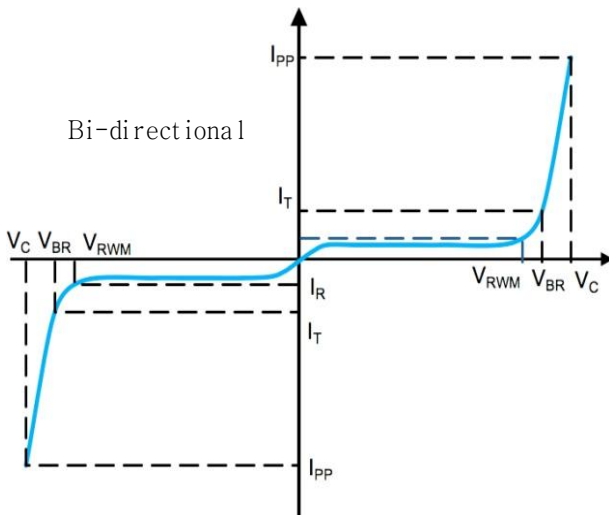


**FIG.5-TYPICAL JUNCTION CAPACITANCE**



Type		Reverse Stand-off Voltage	Breakdown Voltage		Test Current	Reverse Leakage	Max. Clamp Voltage	Peak Pulse Current	Package	
			$V_{BR} @ I_T$						SMA	
		$V_{RRM}$	Min	Max	$I_T$	$I_R @ V_{RRM}$	$V_C @ I_{PP}$	$I_{PP}$	Device Marking Ccode	
UNI	BI	V	V	V	mA	$\mu A$	V	A	UNI	BI
SMAJ180A	SMAJ180CA	180	200	222	1	1	292	1.4	ST	VT

## I-V Curve Characteristics



$P_{PPM}$  Peak Pulse Power Dissipation - Max power dissipation

$V_{RWM}$  Reverse Stand-off Voltage - Maximum voltage that can be applied to TVS without operation

$V_{BR}$  Breakdown Voltage – Maximum voltage that flows though the TVS at a specified current ( $I_T$ )

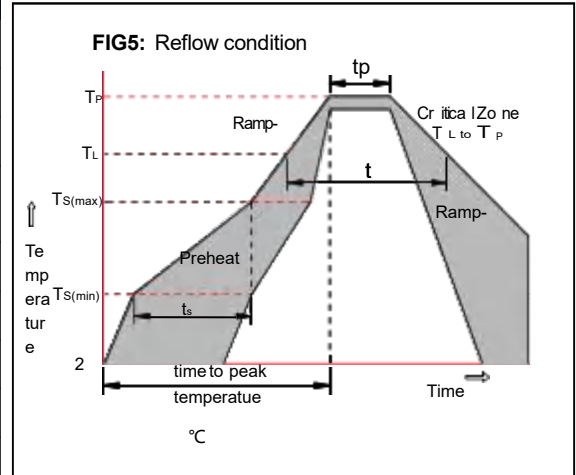
$V_C$  Clamping Voltage – Peak voltage measured across the TVS at a specified  $I_{PPM}$  (peak impulse current)

$I_R$  Reverse Leakage Current – Current measured at  $V_R$

$V_F$  Forward Voltage Drop for Uni-directional

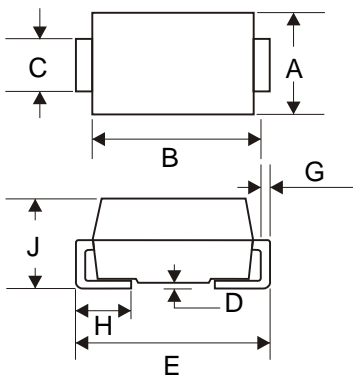
**Soldering parameters**

Reflow Condition		Pb-Free assembly (see as below)
Pre Heat	-Temperature Min ( $T_{s(min)}$ )	+150°C
	-Temperature Max( $T_{s(max)}$ )	+200°C
	-Time (Min to Max) (ts)	60-180 secs.
Average ramp up rate (Liquid us Temp ( $T_L$ ) to peak)		3°C/sec. Max
$T_{s(max)}$ to $T_L$ - Ramp-up Rate		3°C/sec. Max
Reflow	-Temperature( $T_L$ )(Liquid us)	+217°C
	-Temperature( $t_L$ )	60-150 secs.
Peak Temp ( $T_P$ )		+260(+0/-5)°C
Time within 5°C of actual Peak Temp ( $t_p$ )		30 secs. Max
Ramp-down Rate		6°C/sec. Max
Time 25°C to Peak Temp ( $T_P$ )		8 min. Max
Do not exceed		+260°C

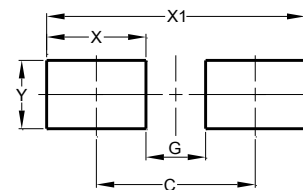


**Package Dimensions & Suggested Pad Layout**

**SMA**



SMA		
Dim	Min	Max
A	2.40	2.79
B	3.99	4.50
C	1.32	1.47
D	-	0.20
E	4.93	5.28
G	0.15	0.31
H	0.76	1.52
J	1.98	2.29
All Dimensions in mm		



Dimensions	Value (in mm)
C	4.20
G	1.90
X	2.30
X1	6.50
Y	2.00

**Tape & reel specification**

Tape		Symbol	Dimension (mm)		
		P0	4.00±0.20		
		P1	4.00±0.20		
		P2	2.00±0.20		
		D0	1.60±0.20		
		D1	1.60±0.20		
		E	1.75±0.20		
		F	5.50±0.15		
		W	12.00±0.25		
		A0	2.75±0.20		
		B0	5.25±0.20		
		K0	2.45±0.25		
		T	0.20±0.10		
		7" Reel		D2	176.0±5.0
				D3	55.0Min.
D4	14.0±2.5				
W1	14.0±2.5				
Quantity: 2000PCS					
13" Reel		D5	330.0±5.0		
		D6	73.0Min.		
		D7	14.0±2.5		
		W2	14.0±2.5		
		Quantity: 5000PCS			