



Low-Power, Slew-Rate-Limited RS-485/RS-422 Transceivers

FEATURES

Electro-Static Discharge (ESD): A/B $\pm 15\text{KV}$ - Human Body Mode (HBM)

Bus allows up to 256 transceivers to be hooked up

Maximum data speed 10 Mbps

Tri-state outputs

APPLICATION

Industrial Controls

Industrial Motor Drives

Automatic HVAC systems

RS485/RS422 Interface

PIN CONFIGURATIONS AND FUNCTIONS

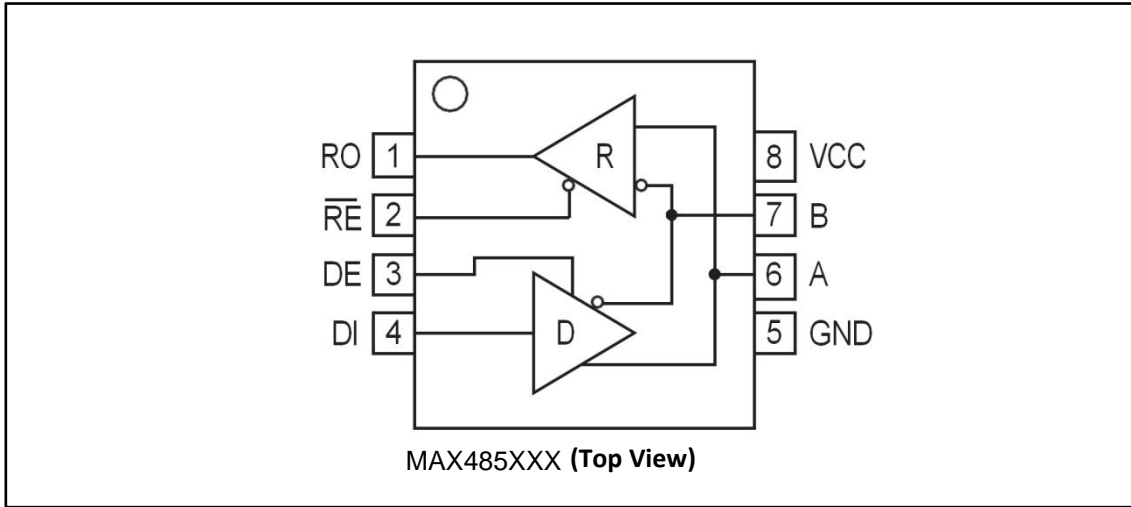

Pin Functions

Pin	Name	Description
1	RO	Receive outputs
2	\overline{RE}	Receive Enable: active low, when high, the receive output is high resistance.
3	DE	Transmit Enable: active high, when DE is low, the transmit output is high resistance. When DE is high, the chip works in transmit state, when DE is low, the chip works in receive state.
4	DI	Transmit data input
5	GND	Ground
6	A	Receive Input/Transmit Output
7	B	Receive Input/Transmit Output
8	Vcc	Power supply

LOGICAL RELATION

MAX485XXX Chip Driver Truth Table

INPUT	ENABLE	OUTPUT	
DI	DE	A	B
H	H	H	L
L	H	L	H
X	L	Z	Z

MAX485XXX Chip Receiver Truth Table

INPUT			OUTPUT
RE	DE	AXB	RO
L	X	>-50mV	H
L	X	<-200mV	L
L	X	Open circuit	H
L	X	Short circuit	H
H	H	X	Z
H	L	X	Z

SPECIFICATIONS

Absolute Maximum Ratings

SYMBOL	PARAMETER	MIN	MAX	UNIT
V _{CC}	Supply voltage range	-	+6.5	V
V _{IN1}	Control Input Voltage (DE, /RE)	-0.3	V _{CC} +0.5V	V
V _{IN2}	Driver Input Voltage (DI)	-0.3	V _{CC} +0.5V	V
V _{RO}	Receiver Output Voltage (RO)	-0.3	V _{CC} +0.5V	V
V _{BUS-OUT}	Driver Output Voltage (bus A, bus B)	-15.0	+15.0	V
V _{BUS-IN}	Receiver Input Voltage (bus A, bus B)	-15.0	+15.0	V
I _{RO}	Receiver Output Current	-60.0	60.0	mA
PD (T _{OP} =+70°C)	Continuous power consumption (MSOP8)	-	400	mW
	Continuous power consumption (SOP8)	-	470	mW
	Continuous power consumption (DIP8)	-	725	mW
T _{OP}	Operation temperature range	-40	+85	°C
T _{STG}	Storage temperature range	-55	+150	°C

DC Characteristics

 (Unless otherwise indicated, $V_{CC}=5V\pm 10\%$, $T_A=25^\circ C\pm 10\%$)

PARAMETER	SYMBOL	TEST CONDITIONS		MIN	TYP	MAX	UNIT
Operating voltage range	V_{CC}			4.5		5.5	V
Driver differential output (no load)	V_{OD1}	-		-	-	5	V
Driver differential output (with load)	V_{OD2}	Figure 1, $R=54\Omega$ or $R=27\Omega$		1.5		-	V
Driver Differential Output Voltage Amplitude of change (Note 2)	ΔV_{OD}			-	-	0.2	V
Driver Common Mode Output Voltage	V_{OC}			1		3	V
Amplitude of change in common mode output voltage of the driver (Note 2)	ΔV_{OC}			-	-	0.2	V
Input High Voltage	V_{IH}	$\overline{DE}, \overline{RE}, DI$		2	-	-	V
Input Low Voltage	V_{IL}	$\overline{DE}, \overline{RE}, DI$		-	-	0.8	V
Input Current	I_{IN1}	DE, RE, DI		-	-	± 2	μA
Input Current (A,B)	I_{IN2}	$DE=0V, V_{CC}=5V$	$V_{IN}=5V$	-	40	90	μA
			$V_{IN}=0V$	-	60	100	
Receiver differential input threshold voltage	V_{TH}	$-7V \leq V_{CM} \leq +12V$		-200	-	-50	mV
Receiver input hysteresis	ΔV_{TH}			-	25	-	mV
Receiver output high	V_{OH}	$I_o = -4mA$		4	-	-	V
Receiver output low	V_{OL}	$I_o = 4mA$		-	-	0.4	V
Receiver-side tri-state (high-resistance) output current	I_{OZR}	$0.4V \leq V_o \leq 2.4V$		-	-	1	μA
Receiver Input Impedance	R_{IN}	$-7V \leq V_{CM} \leq +12V$		96	-	-	$k\Omega$
No-load operating current	I_{CC}	No-load, $\overline{RE} = DI = GND$ 或 V_{CC}	$DE = V_{CC}$	-	480	600	μA
			$DE = GND$	-	450	600	μA
Receiver output short-circuit current	I_{OSR}	$0V \leq V_{RO} \leq V_{CC}$		-	-	50	mA
ESD protection		A/B, Body Mode		± 8	± 15	-	kV

Switching Characteristics

PARAMETER	SYMBOL	TEST CONDITIONS	MIN	TYP	MAX	UNIT
Drive Input to Output	tDPLH	Figure 3 and Figure 5 RDIFF=50Ω CL1=CL2=100pF	-	34	60	nS
	tDPHL		-	34	60	nS
Driver Output Offset tDPLH – tDPHL	tDSKEW		-	-2.5	±10	nS
Drive Rise and Fall Time	tDR		-	10	25	nS
	tDF		-	10	25	nS
Driver enable to output high	tDZH		Figure 4 and Figure 6, CL=100pF S2 close	-	-	150
Driver enable to output low	tDZL	Figure 4 and Figure 6, CL=100pF S1 close	-	-	150	nS
Drive from low to off	tDLZ	Figure 4 and Figure 6, CL=15pF S1 close	-	-	100	nS
Drive from high to off	tDHZ	Figure 4 and Figure 6, CL=15pF S2 close	-	-	100	nS
Receiver input to output	tRPLH	Figure 7 and Figure 9, VID ≥ 2.0V; VID Rise and fall time ≤15nS	-	-	150	nS
	tRPHL		-	-	150	nS
Differential Receiver Offset tRPLH - tRPHL	tRSKEW		-	0	±10	nS
Receiver enable to output low	tRZL	Figure 2 and Figure 8 CL=100pF S1 close	-	20	50	nS
Receiver enable to output high	tRZH	Figure 2 and Figure 8 CL=100pF S2 close	-	20	50	nS
Receiver low to off	tRLZ	Figure 2 和 Figure 8 CL=100pF S1 close	-	20	50	nS
Receiver high to off	tRHZ	Figure 2 和 Figure 8 CL=100pF S2 close	-	20	50	nS
Driver output short-circuit current	I _{OD}	Short-circuit current between A/B	-	-	100	mA
Maximum data speed	f _{MAX}		-	-	10	Mbps

Test line and switch waveforms

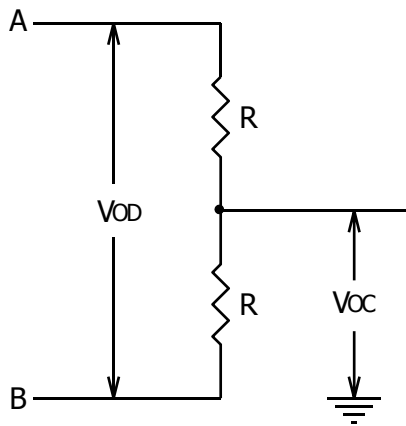

Figure 1: Driver DC Characteristics Test Load

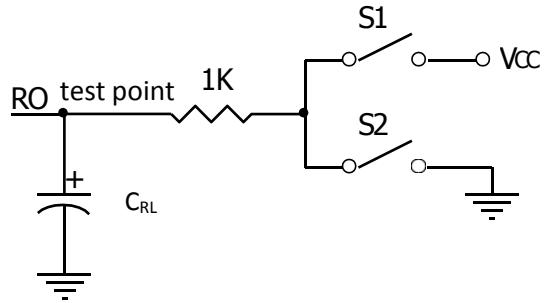

Figure 2: Receiver Enable/Off Switching Characteristics Test Load

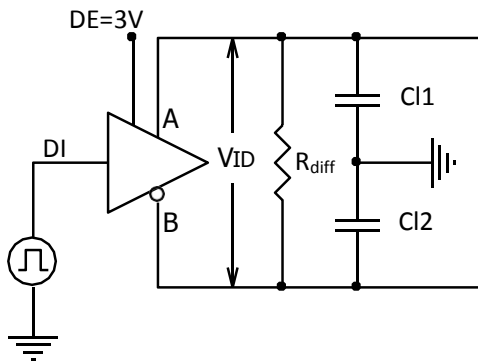

Figure 3: Driver Switching Characteristics Test Load

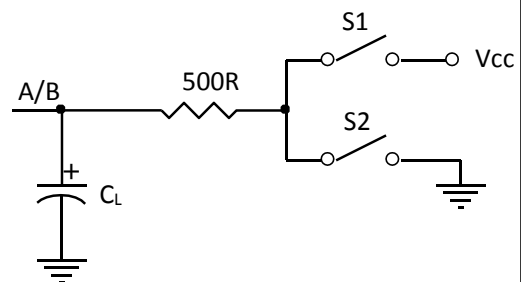

Figure 4: Driver Enable/Off Switching Characteristics Test Load

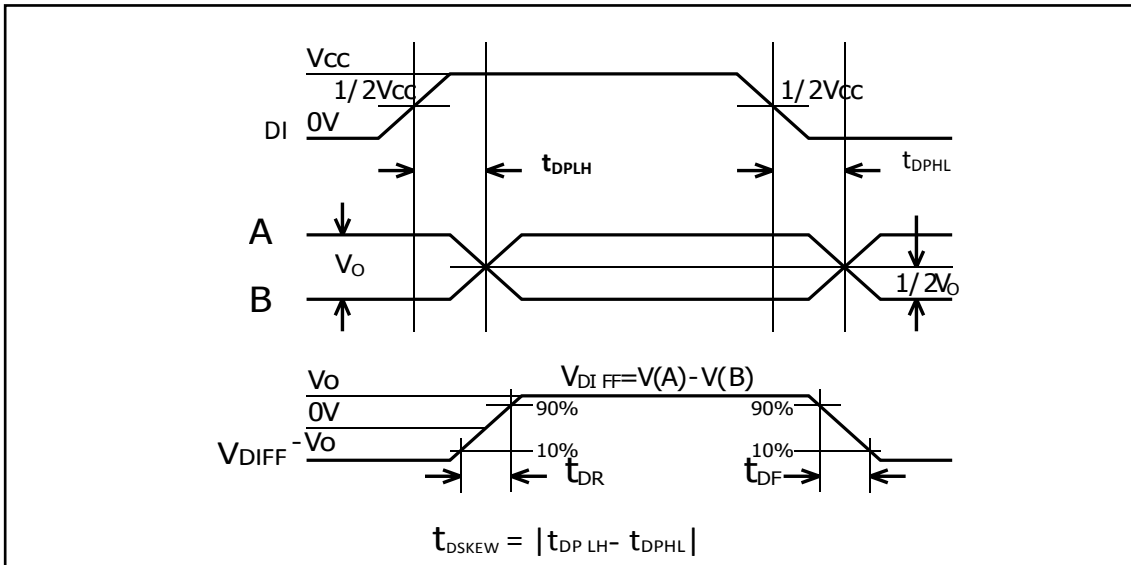

Figure 5: Drive Transfer Delay

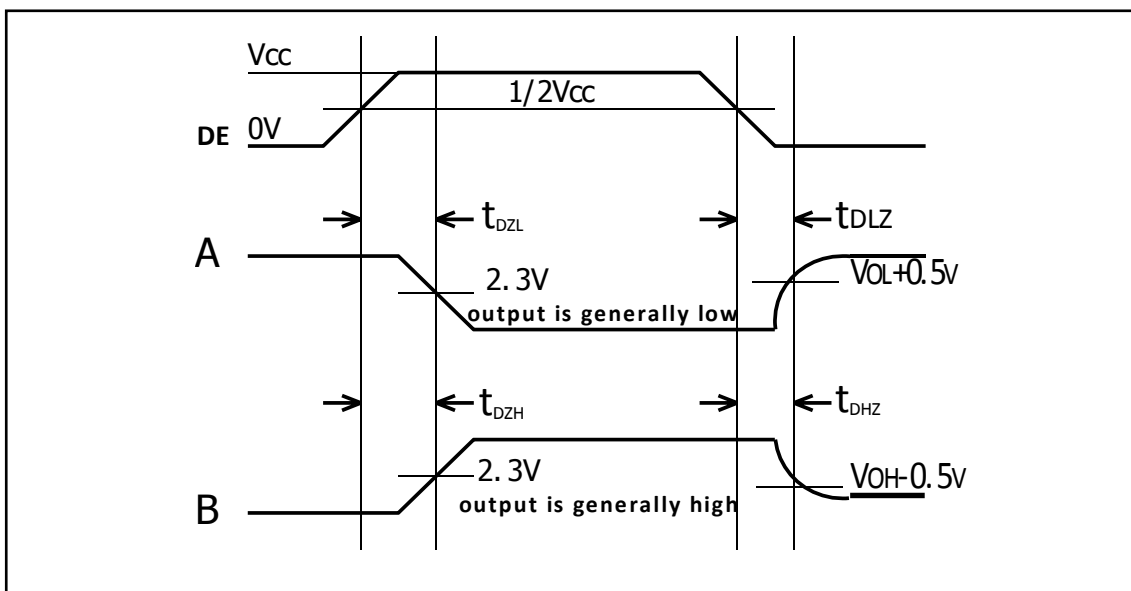

Figure 6: Driver Enable/Off Timing

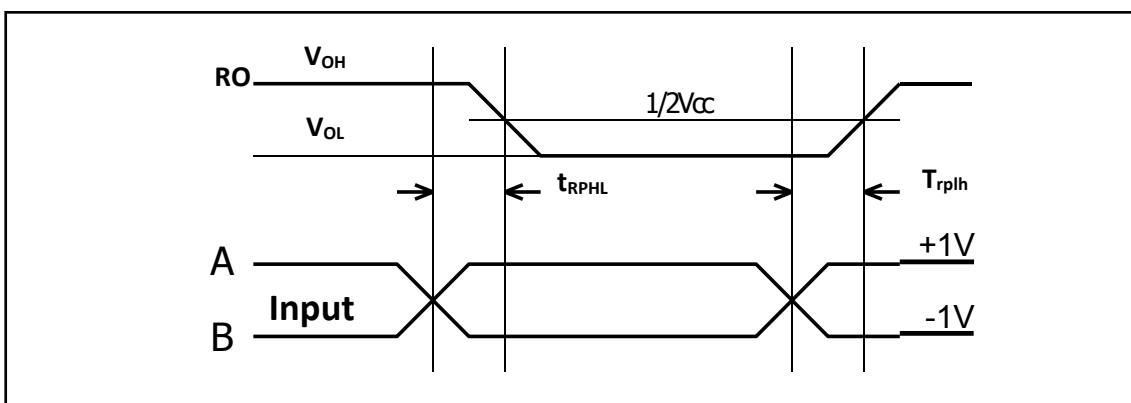

Figure 7: Receiver Transmission Delay

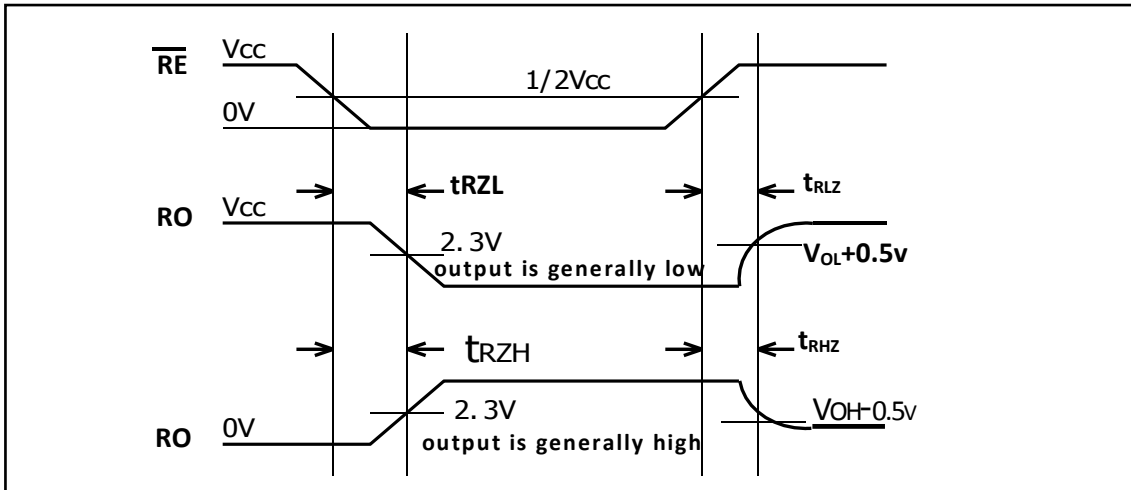

Figure 8: Receiver Enable/Off Timing

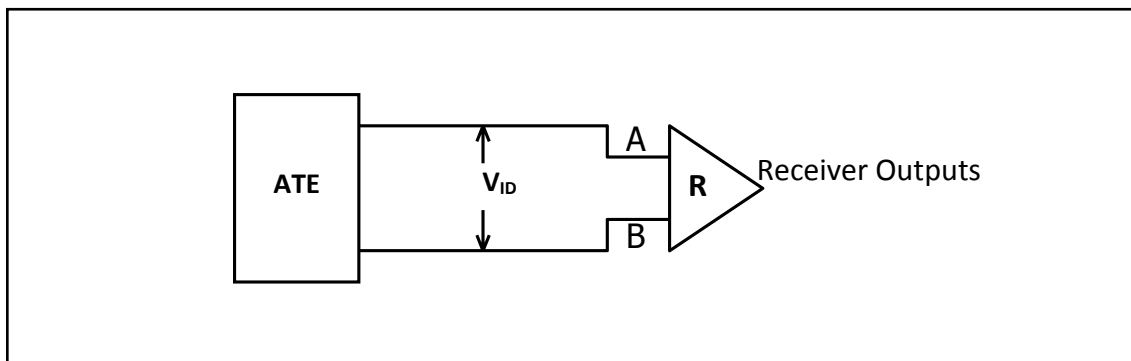

Figure 9: Receiver Transmission Delay Test Circuitry

Typical Application Diagram

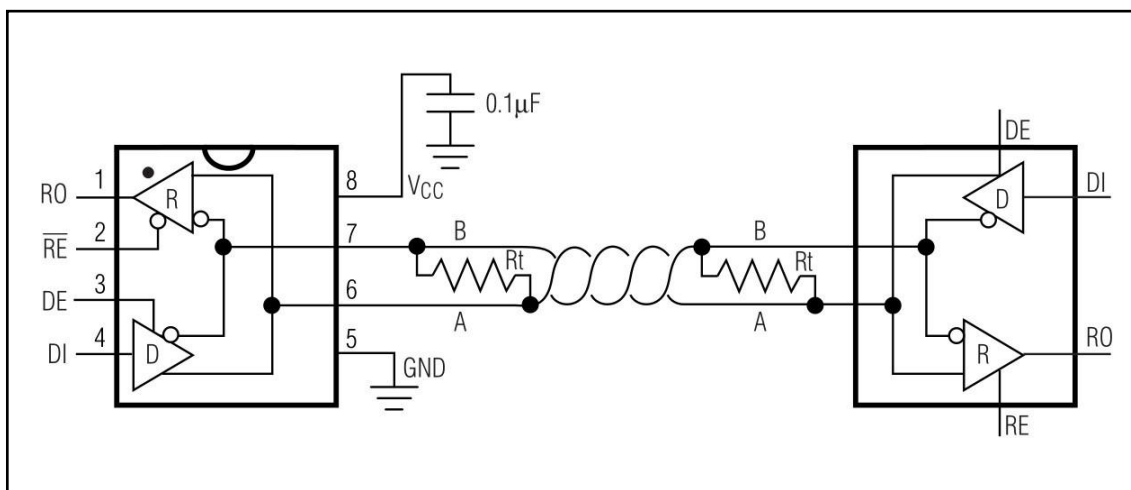

Figure 10: Typical Half-Duplex Operation Circuit for MAX485XXX

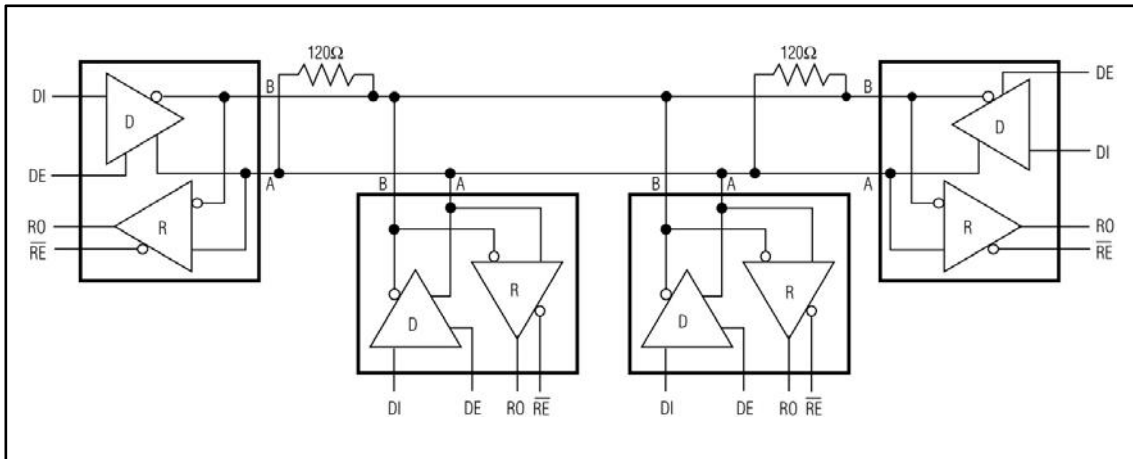

Figure 11: Typical half-duplex MAX485XXX operating network

ORDERING INFORMATION

Ordering Information

Part Number	Device Marking	Package Type	Body size (mm)	Temperature (°C)	MSL	Transport Media	Package Quantity
MAX485ESA	MAX485	SOP8	4.90 * 3.90	-40 to +85	MSL3	T&R	2500
MAX485ESB	MAX485	MSOP8	3.00 * 3.00	-40 to +85	MSL3	T&R	2500
MAX485ESC	MAX485	DIP8	9.25 * 6.38	-40 to +85	MSL3	Tube 50	2000

DIMENSIONAL DRAWINGS

SOP8

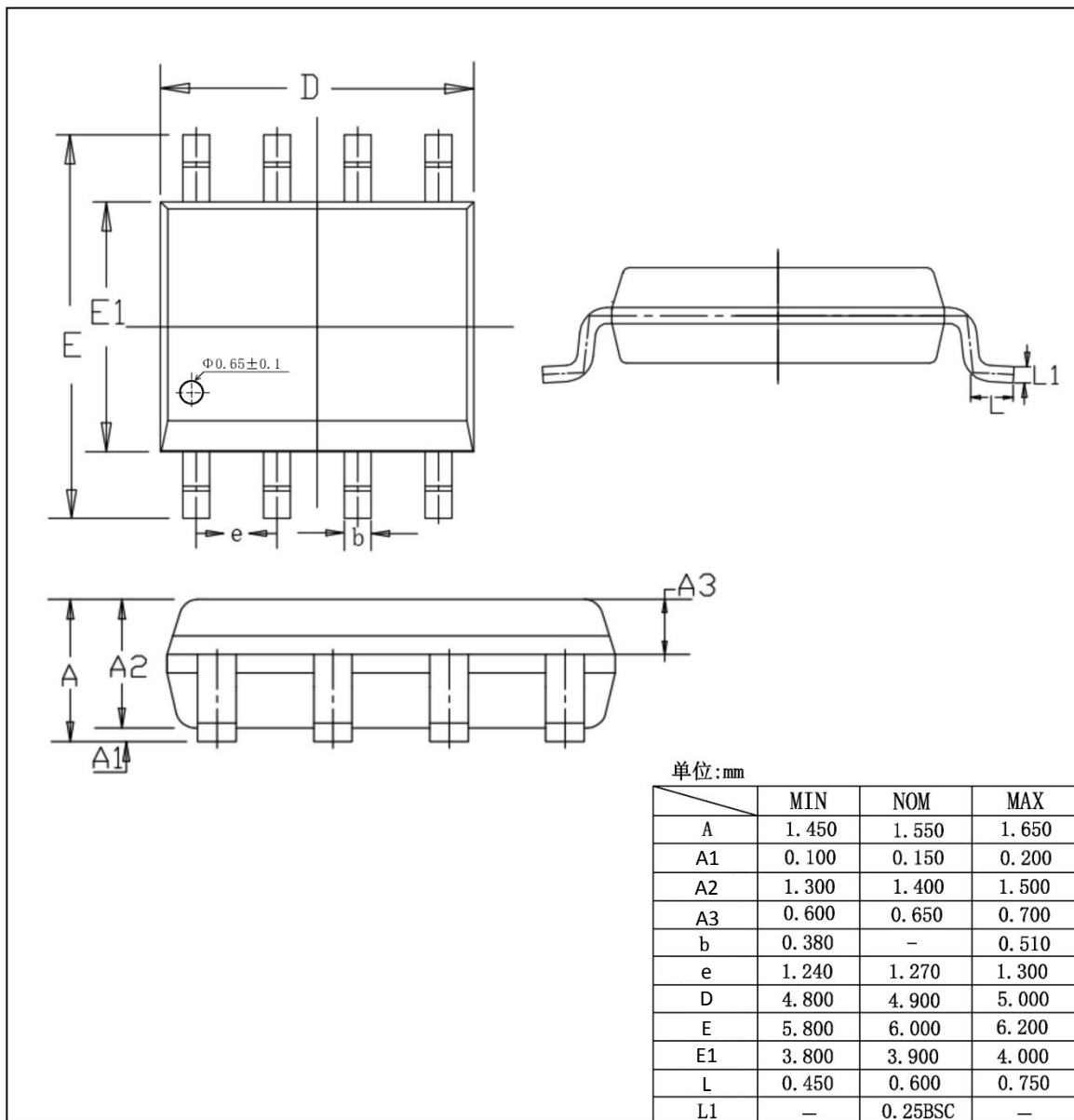

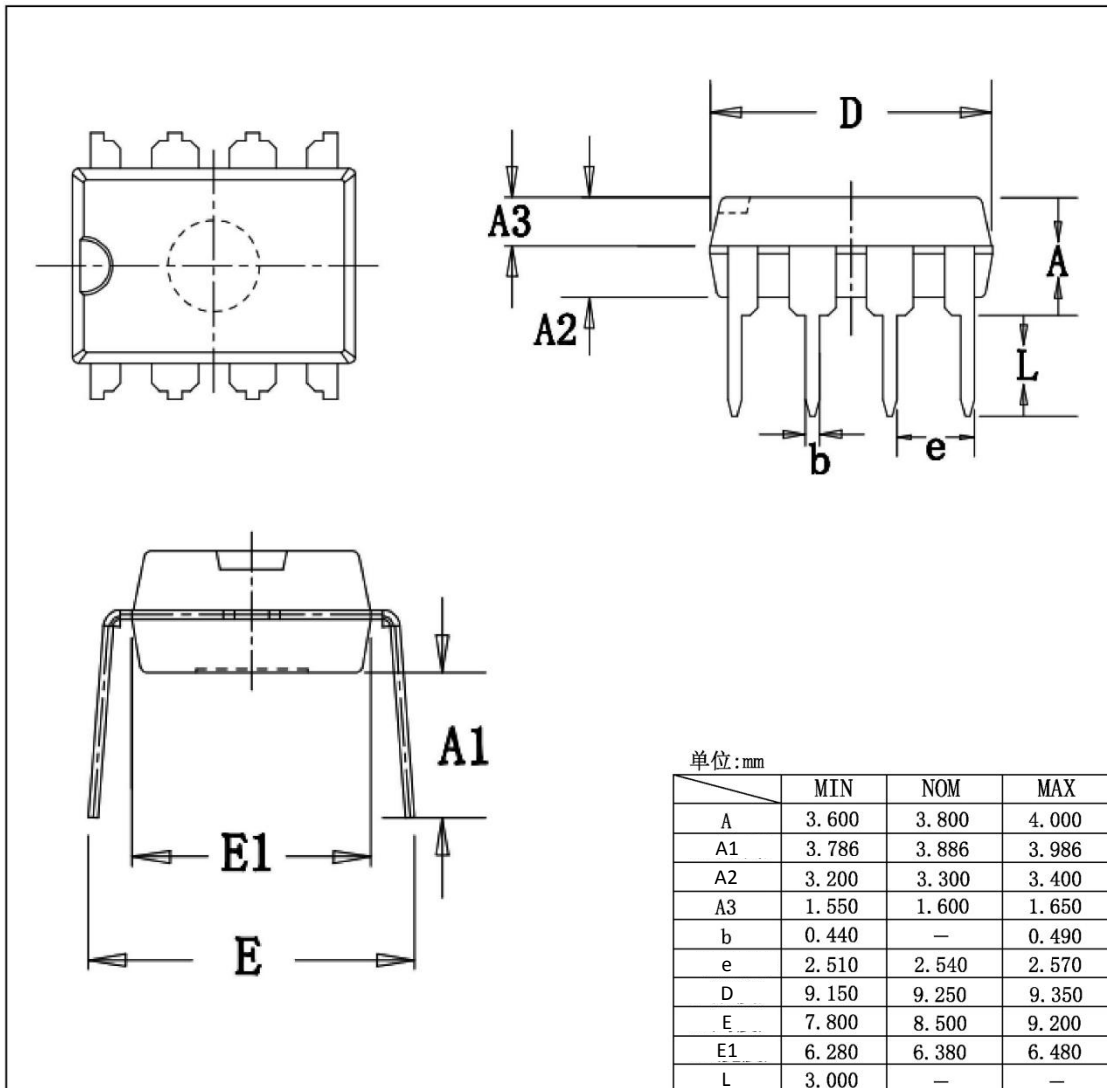
DIP8

MSOP8

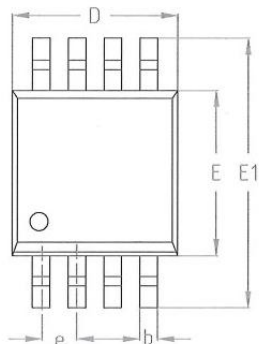
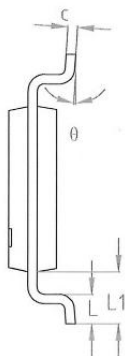
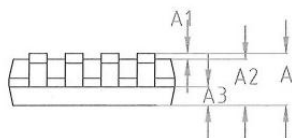
 TOP VIEW
正视图

 SIDE VIEW
侧视图

 SIDE VIEW
侧视图

机械尺寸/mm Dimensions			
字符 SYMBOL	最小值 MIN	典型值 NOMINAL	最大值 MAX
A	-	-	1.10
A1	0.05	-	0.15
A2	0.75	0.85	0.95
A3	0.30	0.35	0.40
b	0.28	-	0.36
c	0.15	-	0.19
D	2.90	3.00	3.10
E	2.90	3.00	3.10
E1	4.70	4.90	5.10
e	0.65 BSC		
L1	0.95 REF		
L	0.40	-	0.70
θ	0°	-	8°