

RoHS

REV	ECN NO.	DESCRIPTION	DESIGN	APPROVAL	DATE
A1	NEW	新版发行			2026.04.14

AUTO FUS
(2)PLS

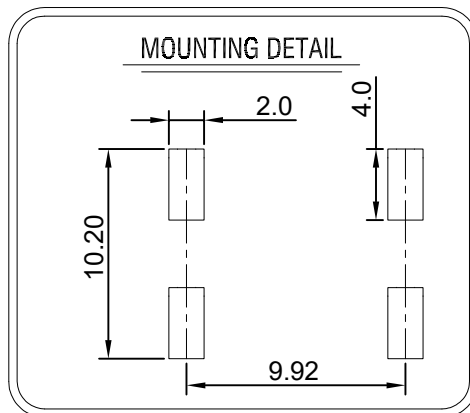
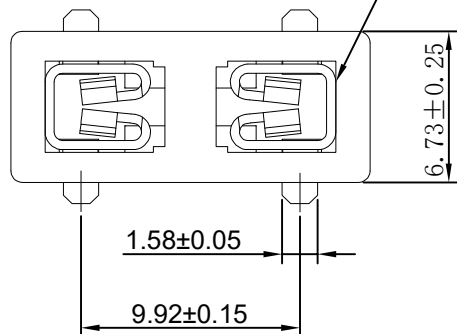

SPECIFICATIONS
 Current Rating: 30 Amps @ 500V AC
 Temperature Rating: -40 °C to 125 °C
 Insulator: Nylon 6T , UL 94V-0
 Contacts: Brass,
 Finish: Tin plated over Nickel
 Fuse Size: Mini automotive blade Fuses
 Max.Processing Temp:230°C for 30-60 seconds
 (260°C for 10 seconds)

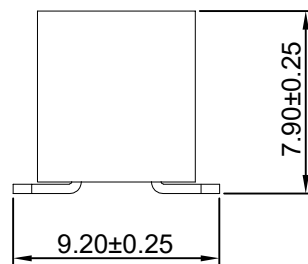
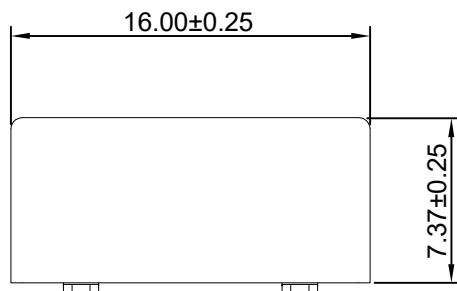

ACTUAL SIZE

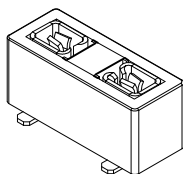

X.±0.50	X.°±	PART NO:		XFCN 兴飞连接器		
.X±0.25	.X°±	XF-508PVS-B-B-D				
.XX±0.15	.XX°±	TITLE:		0769-82001899		
.XXX±0.10	.XXX°±	迷你(微型)汽车刀片保险丝座		www.xfconn.com		
UNITS:	mm			DWG NO: /		
THESE DRAWINGS AND SPECIFICATIONS ARE THE PROPERTY OF XFCN AND SHALL NOT BE REPRODUCED, COPIED OR CUED IN ANY MANNER WITHOUT THE PRIOR WRITTEN CONSENT OF XFCN		APPD	Chen ZhiQiang	VIEW		
		CHKD	Liu Wei	SCALE	SHEET	
		DRAW	Chen HongJiang	SCALE	SHEET	REV
		DATE	2026.04.14	NONE	1/1	A1