

Enhanced ESD, 3.0kV rms 200Mbps Single-Channel Digital Isolators

FEATURES

Ultra-low power consumption (1Mbps): 0.75mA/Channel

High data rate: 200Mbps

High common-mode transient immunity: 75 kV/ μ s typical

High robustness to radiated and conducted noise

Low propagation delay:

8 ns typical for 5 V operation

9 ns typical for 3.3 V operation

Isolation voltages: AC 3000Vrms

High ESD rating:

ESDA/JEDEC JS-001-2017

Human body model (HBM) \pm 8kV

Safety and regulatory approvals:

3000Vrms for 1 minute per UL 1577

CSA Component Acceptance Notice 5A

DIN VDE V 0884-11:2017-01

$V_{IORM} = 565V$ peak

3 V to 5.5 V level translation

Wide temperature range: $-40^{\circ}C$ to $125^{\circ}C$

RoHS-compliant, NB SOIC-8 package

FUNCTIONAL BLOCK DIAGRAMS

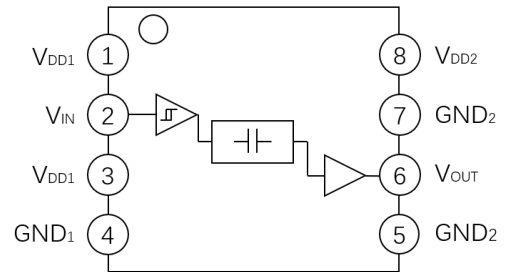

Figure 1. ISO7221 functional Block Diagram

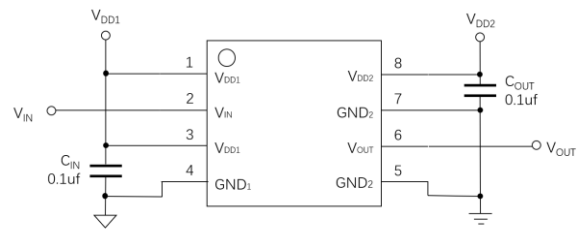

Figure 2. ISO7221 Typical Application Circuit

APPLICATIONS

General-purpose Single-channel isolation

Industrial field bus

Isolation Industrial automation systems

Isolated switch mode supplies

Isolated ADC, DAC

Motor control

PIN CONFIGURATIONS AND FUNCTIONS

Table 1. ISO7221 Pin Function Descriptions

Pin No.	Name	Description
1	V _{DD1}	Supply Voltage for Isolator Side 1.
2	V _{IN}	Logic Input.
3	V _{DD1}	Supply Voltage for Isolator Side 1.
4	GND ₁	Ground 1. This pin is the ground reference for Isolator Side 1.
5	GND ₂	Ground 2. This pin is the ground reference for Isolator Side 2.
6	V _{OUT}	Logic Output.
7	GND ₂	Ground 2. This pin is the ground reference for Isolator Side 2.
8	V _{DD2}	Supply Voltage for Isolator Side 2.

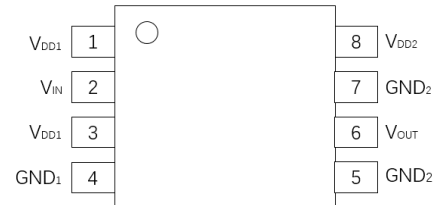

Figure 3. ISO7221 Pin Configuration

ABSOLUTE MAXIMUM RATINGS

T_A = 25°C, unless otherwise noted.

 Table 2. Absolute Maximum Ratings⁴

Parameter	Rating
Supply Voltages (V _{DD1} -GND ₁ , V _{DD2} -GND ₂)	-0.5 V to +7.0 V
Input Voltages ¹	-0.5 V to V _{DDx} + 0.5 V
Output Voltages ¹	-0.5 V to V _{DDx} + 0.5 V
Average Output Current per Pin ² Side 1 Output Current (I _{O1})	-10 mA to +10 mA
Average Output Current per Pin ² Side 2 Output Current (I _{O2})	-10 mA to +10 mA
Common-Mode Transients Immunity ³	-200 kV/μs to +200 kV/μs
Storage Temperature (T _{ST}) Range	-65°C to +150°C
Ambient Operating Temperature (T _A) Range	-40°C to +125°C

Notes:

¹ V_{DDx} is the side voltage power supply V_{DD}, where x = 1 or 2.

² See Figure 4 for the maximum rated current values for various temperatures.

³ See Figure 11 for Common-mode transient immunity (CMTI) measurement.

⁴ Stresses at or above those listed under Absolute Maximum Ratings may cause permanent damage to the device. These are stress rating only; functional operation of the device at these or any other conditions above those indicated in the operational section of this specification is not implied. Operation beyond the maximum operating conditions for extended periods may affect product reliability.

RECOMMENDED OPERATING CONDITIONS

Table 3. Recommended Operating Conditions

Parameter	Symbol	Min	Typ	Max	Unit
Supply Voltage	V _{DDx} ¹	3		5.5	V
High Level Input Signal Voltage	V _{IH}	0.7*V _{DDx} ¹		V _{DDx} ¹	V
Low Level Input Signal Voltage	V _{IL}	0		0.3*V _{DDx} ¹	V
High Level Output Current	I _{OH}	-6			mA
Low Level Output Current	I _{OL}			6	mA
Data Rate		0		200	Mbps
Junction Temperature	T _J	-40		150	°C
Ambient Operating Temperature	T _A	-40		125	°C

Notes:

¹ V_{DDx} is the side voltage power supply V_{DD}, where x = 1 or 2.

Truth Tables

Table 4. ISO7221 Truth Table

V _{ix} Input ¹	V _{DDI} State ¹	V _{DDO} State ¹	Default Low V _{ox} Output ¹	Default High V _{ox} Output ¹	Test Conditions /Comments
Low	Powered ²	Powered ²	Low	Low	Normal operation
High	Powered ²	Powered ²	High	High	Normal operation
Open	Powered ²	Powered ²	Low	High	Default output
Don't Care ⁴	Unpowered ³	Powered ²	Low	High	Default output ⁵
Don't Care ⁴	Powered ²	Unpowered ³	High Impedance	High Impedance	

Notes:

¹ V_{ix}/V_{ox} are the input/output signals of a given channel (A or B). V_{DDI}/V_{DDO} are the supply voltages on the input/output signal sides of this given channel.

² Powered means V_{DDx} ≥ 2.95 V

³ Unpowered means V_{DDx} < 2.30V

⁴ Input signal (V_{ix}) must be in a low state to avoid powering the given V_{DDI}¹ through its ESD protection circuitry.

⁵ If the V_{DDI} goes into unpowered status, the channel outputs the default logic signal after around 1 μ s. If the V_{DDI} goes into powered status, the channel outputs the input status logic signal after around 1 μ s.

SPECIFICATIONS

ELECTRICAL CHARACTERISTICS

Table 5. Switching Specifications

V_{DD1} - V_{GND1} = V_{DD2} - V_{GND2} = 3.3V_{DC} ± 10% or 5V_{DC} ± 10%, T_A = 25°C, unless otherwise noted.

Parameter	Symbol	Min	Typ	Max	Unit	Test Conditions/Comments
Minimum Pulse Width	PW			5	ns	Within pulse width distortion (PWD) limit
Maximum Data Rate		200			Mbps	Within PWD limit
Propagation Delay Time ¹	t _{pHL} , t _{pLH}	5.5	8	12.5	ns	@ 5V _{DC} supply
		6.5	9	13.5	ns	@ 3.3V _{DC} supply
Pulse Width Distortion	PWD	0	0.3	3.0	ns	The max different time between t _{pHL} and t _{pLH} @ 5V _{DC} supply. And The value is t _{pHL} - t _{pLH}
		0	0.3	3.0	ns	@ 3.3V _{DC} supply
Part to Part Propagation Delay Skew	t _{PSK}			2	ns	The max different propagation delay time between any two devices at the same temperature, load and voltage @ 5V _{DC} supply
				2	ns	@ 3.3V _{DC} supply
Output Signal Rise/Fall Time ⁴	t _r /t _f		1.5		ns	See Figure 7.
Dynamic Input Supply Current per Channel	I _{DDI(D)}		9		μ A /Mbps	Inputs switching, 50% duty cycle square wave, CL = 0 pF @ 5V _{DC} Supply
Dynamic Output Supply Current per Channel	I _{DDO(D)}		38		μ A /Mbps	Inputs switching, 50% duty cycle square wave, CL = 0 pF @ 5V _{DC} Supply
Dynamic Input Supply Current per Channel	I _{DDI(D)}		5		μ A /Mbps	Inputs switching, 50% duty cycle square wave, CL = 0 pF @ 3.3V _{DC} Supply
Dynamic Output Supply Current per Channel	I _{DDO(D)}		23		μ A /Mbps	Inputs switching, 50% duty cycle square wave, CL = 0 pF @ 3.3V _{DC} Supply
Common-Mode Transient Immunity ³	CMTI		75		kV/ μ s	V _{IN} = V _{DDx} ² or 0V, V _{CM} = 1000 V
Jitter			120		ps p-p	See the Jitter Measurement section
			20		ps rms	
ESD(HBM - Human body model)	ESD		±8		kV	

Notes:

¹ t_{pLH} = low-to-high propagation delay time, t_{pHL} = high-to-low propagation delay time. See Figure 8.

² V_{DDx} is the side voltage power supply V_{DD}, where x = 1 or 2.

³ See Figure 11 for Common-mode transient immunity (CMTI) measurement.

⁴ t_r means is the time from 10% amplitude to 90% amplitude of the rising edge of the signal, t_f means is the time from 90% amplitude to 10% amplitude of the falling edge of the signal.

Table 6. DC Specifications

 $V_{DD1} - V_{GND1} = V_{DD2} - V_{GND2} = 3.3VDC \pm 10\%$ or $5VDC \pm 10\%$, $T_A = 25^\circ C$, unless otherwise noted.

	Symbol	Min	Typ	Max	Unit	Test Conditions/Comments
Rising Input Signal Voltage Threshold	V_{IT+}		$0.6 * V_{DDx}^1$	$0.7 * V_{DDx}^1$	V	
Falling Input Signal Voltage Threshold	V_{IT-}	$0.3 * V_{DDx}^1$	$0.4 * V_{DDx}^1$		V	
High Level Output Voltage	V_{OH}^1	$V_{DDx} - 0.1$	V_{DDx}		V	-20 μA output current
		$V_{DDx} - 0.2$	$V_{DDx} - 0.1$		V	-2 mA output current
Low Level Output Voltage	V_{OL}		0	0.1	V	20 μA output current
			0.1	0.2	V	2 mA output current
Input Current per Signal Channel	I_{IN}	-10	0.5	10	μA	$0 V \leq \text{Signal voltage} \leq V_{DDx}^1$
V_{DDx}^1 Undervoltage Rising Threshold	V_{DDxUV+}	2.45	2.75	2.95	V	
V_{DDx}^1 Undervoltage Falling Threshold	V_{DDxUV-}	2.30	2.60	2.75	V	
V_{DDx}^1 Hysteresis	V_{DDxUVH}		0.15		V	

Notes:

¹ V_{DDx} is the side voltage power supply V_{DD} , where $x = 1$ or 2 .

Table 7. Quiescent Supply Current

 $V_{DD1} - V_{GND1} = V_{DD2} - V_{GND2} = 3.3VDC \pm 10\%$ or $5VDC \pm 10\%$, $T_A = 25^\circ C$, $C_L = 0$ pF, unless otherwise noted.

Part	Symbol	Min	Typ	Max	Unit	Test Conditions	
						Supply voltage	Input signal
ISO7221	$I_{DD1}(Q)$	0.06	0.08	0.10	mA	$5V_{DC}$	$V_I = 0V$ for ISO7222
	$I_{DD2}(Q)$	0.47	0.59	0.76	mA		$V_I = 5V$ for ISO7221
	$I_{DD1}(Q)$	0.15	0.19	0.25	mA		$V_I = 5V$ for ISO7222
	$I_{DD2}(Q)$	0.44	0.55	0.72	mA		$V_I = 0V$ for ISO7221
	$I_{DD1}(Q)$	0.06	0.08	0.10	mA	$3.3V_{DC}$	$V_I = 0V$ for ISO7222
	$I_{DD2}(Q)$	0.46	0.58	0.75	mA		$V_I = 3.3V$ for ISO7221
	$I_{DD1}(Q)$	0.11	0.14	0.18	mA		$V_I = 3.3V$ for ISO7222
	$I_{DD2}(Q)$	0.43	0.53	0.69	mA		$V_I = 0V$ for ISO7221

 Table 8. Total Supply Current vs. Data Throughput ($C_L = 0$ pF)

 $V_{DD1} - V_{GND1} = V_{DD2} - V_{GND2} = 3.3VDC \pm 10\%$ or $5VDC \pm 10\%$, $T_A = 25^\circ C$, $C_L = 0$ pF, unless otherwise noted.

Part	Symbol	2 Mbps			20 Mbps			200 Mbps			Unit	Supply voltage
		Min	Typ	Max	Min	Typ	Max	Min	Typ	Max		
ISO7221	I_{DD1}		0.21	0.34		0.34	0.54		2.09	3.34	mA	$5V_{DC}$
	I_{DD2}		0.93	1.49		1.71	2.73		9.57	15.32		
	I_{DD1}		0.16	0.26		0.26	0.42		1.23	1.97	mA	$3.3V_{DC}$
	I_{DD2}		0.87	1.39		1.40	2.25		6.23	9.97		

INSULATION AND SAFETY RELATED SPECIFICATIONS

Table 9. Insulation Specifications

Parameter	Symbol	Value	Unit	Test Conditions/Comments
Rated Dielectric Insulation Voltage		3000	V rms	1-minute duration
Minimum External Air Gap (Clearance)	L (CLR)	≥ 4	mm	Measured from input terminals to output terminals, shortest distance through air
Minimum External Tracking (Creepage)	L (CRP)	≥ 4	mm	Measured from input terminals to output terminals, shortest distance path along body
Minimum Internal Gap (Internal Clearance)		≥ 11	μm	Insulation distance through insulation
Tracking Resistance (Comparative Tracking Index)	CTI	> 400	V	DIN EN 60112 (VDE 0303-11):2010-05
Material Group		II		IEC 60112:2003 + A1:2009

PACKAGE CHARACTERISTICS

Table 10.Package Characteristics

Parameter	Symbol	Typical Value	Unit	Test Conditions/Comments
Resistance (Input to Output) ¹	R _{IO}	10 ¹¹	Ω	
Capacitance (Input to Output) ¹	C _{IO}	0.6	pF	@1MHz
Input Capacitance ²	C _I	3.0	pF	@1MHz
IC Junction to Ambient Thermal Resistance	θ _{JA}	100	°C/W	Thermocouple located at center of package underside

Notes:

¹The device is considered a 2-terminal device; SOIC-8 Pin 1 - Pin 4 are shorted together as the one terminal, and SOIC-8 Pin 5 - Pin 8 are shorted together as the other terminal.

²Testing from the input signal pin to ground.

REGULATORY INFORMATION

See Table 11 for details regarding recommended maximum working voltages for specific cross isolation waveforms and insulation levels.

Table 11.Regulatory

Regulatory	ISO7221
UL	Recognized under UL 1577 Component Recognition Program Single Protection, 3000 V rms Isolation Voltage File
VDE	DIN VDE V 0884-11:2017-01 Basic insulation, V _{IORM} = 565V peak, V _{IOSM} = 3615 V peak File
CQC	Certified under CQC11-471543-2012, GB4943.1-2011 Basic insulation at 500 V rms (707 V peak) working voltage Reinforced insulation at 250 V rms (353 V peak) NB SOIC-8 File

DIN V VDE V 0884-11 (VDE V 0884-11) INSULATION CHARACTERISTICS

Table 12.VDE Insulation Characteristics

Description	Test Conditions/Comments	Symbol	Characteristic	Unit
Installation Classification per DIN VDE 0110 For Rated Mains Voltage ≤ 150 V rms For Rated Mains Voltage ≤ 300 V rms For Rated Mains Voltage ≤ 400 V rms			I to IV I to III I to III	
Climatic Classification			40/105/21	
Pollution Degree per DIN VDE 0110, Table 1			2	
Maximum repetitive peak isolation voltage		V _{IORM}	565	Vpeak
Input to Output Test Voltage, Method B1	V _{IORM} × 1.5 = V _{pd(m)} , 100% production test, t _{ini} = t _m = 1 sec, partial discharge < 5 pC	V _{pd(m)}	848	Vpeak
Input to Output Test Voltage, Method A After Environmental Tests Subgroup 1	V _{IORM} × 1.3 = V _{pd(m)} , t _{ini} = 60 sec, t _m = 10 sec, partial discharge < 5 pC	V _{pd(m)}	735	1560
After Input and/or Safety Test Subgroup 2 and Subgroup 3	V _{IORM} × 1.2 = V _{pd(m)} , t _{ini} = 60 sec, t _m = 10 sec, partial discharge < 5 pC	V _{pd(m)}	678	1440
Highest Allowable Overvoltage		V _{IOTM}	4200	Vpeak

Description	Test Conditions/Comments	Symbol	Characteristic	Unit
Surge Isolation Voltage Basic	Basic insulation, 1.2/50 μ s combination wave, $V_{TEST} = 1.3 \times V_{IOSM}$ (qualification)	V_{IOSM}	3615	Vpeak
Safety Limiting Values	Maximum value allowed in the event of a failure (see <i>Figure 4</i>)			
Maximum Safety Temperature		T_S	150	$^{\circ}$ C
Maximum Power Dissipation at 25 $^{\circ}$ C		P_S	1.25	W
Insulation Resistance at T_S	$V_{IO} = 500$ V	R_S	$>10^9$	Ω

Typical Thermal Characteristic

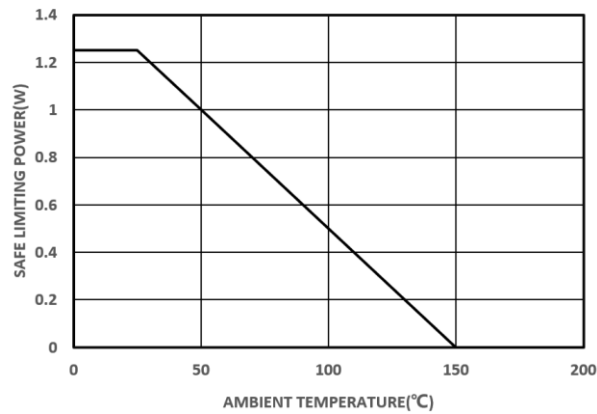

Figure 4. Thermal Derating Curve, Dependence of Safety Limiting Values with Ambient Temperature per VDE

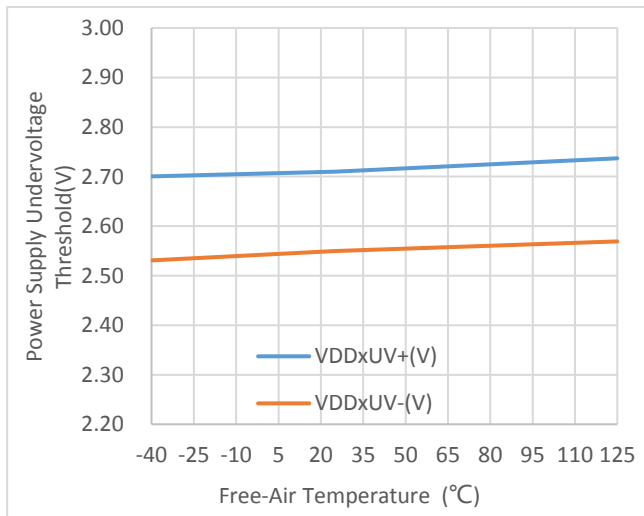

Figure 5. UVLO vs. Free-Air Temperature

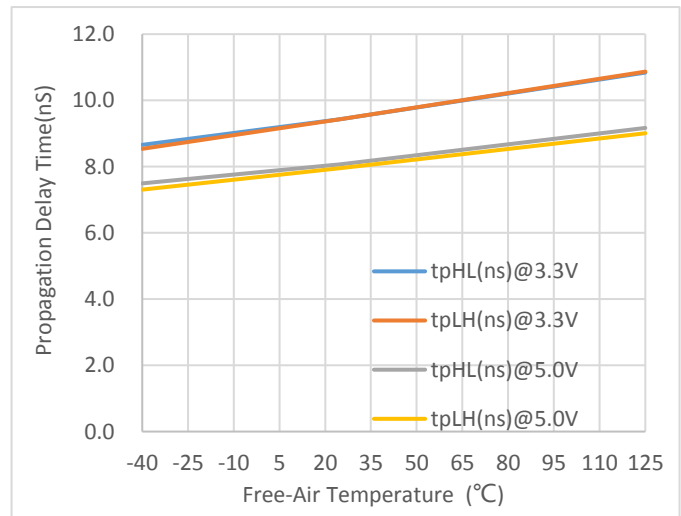

Figure 6. Propagation Delay Time vs. Free-Air Temperature

Timing test information

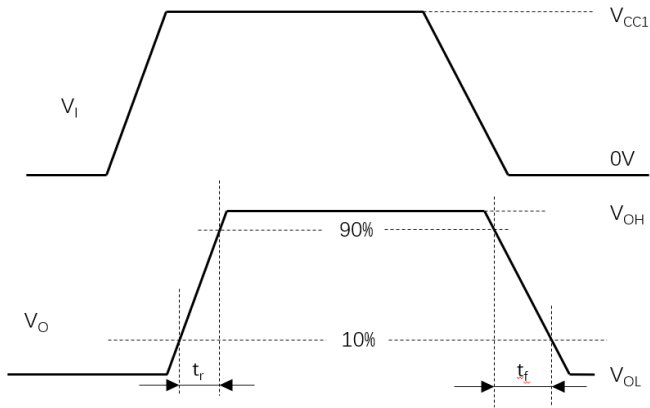

Figure 7. Transition time waveform measurement

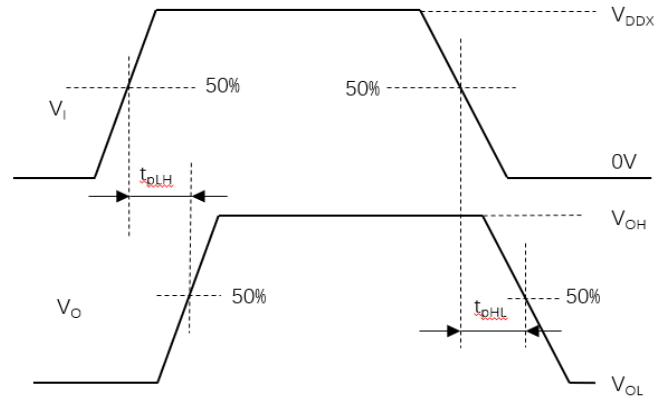

Figure 8. Propagation delay time waveform measurement

PCB LAYOUT

The low-ESR ceramic bypass capacitors must be connected between V_{DD1} and GND_1 and between V_{DD2} and GND_2 . The bypass capacitors are placed on the PCB as close to the isolator device as possible. The recommended bypass capacitor value is between 0.1 μF and 10 μF . To enhance the robustness of a design, the user may also include resistors (50–300 Ω) in series with the inputs and outputs if the system is excessively noisy.

Avoid reducing the isolation capability, Keep the space underneath the isolator device free from metal such as planes, pads, traces and vias.

To minimize the impedance of the signal return loop, keep the solid ground plane directly underneath the high-speed signal path, the closer the better. The return path will couple between the nearest ground plane to the signal path. Keep suitable trace width for controlled impedance transmission lines interconnect.

To reduce the rise time degradation, keep the length of input/output signal traces as short as possible, and route low inductance loop for the signal path and its return path.

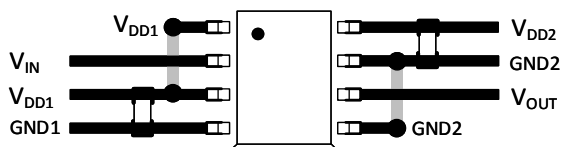

Figure 9. Recommended Printed Circuit Board Layout

JITTER MEASUREMENT

The eye diagram shown in the figure below provides the jitter measurement result for the ISO7221. The Keysight 81160A pulse function arbitrary generator works as the data source for the ISO7221, which generates 100Mbps pseudo random bit sequence (PRBS). The Keysight DSOS104A digital storage oscilloscope captures the ISO7221 output waveform and recovers the eye diagram with the SDA tools and eye diagram analysis tools. The result shows a typical measurement jitter data.

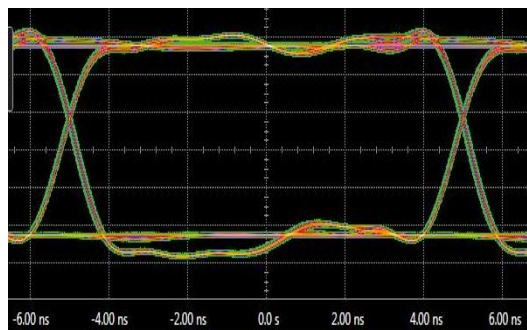

Figure 10. Eye Diagram

CMTI MEASUREMENT

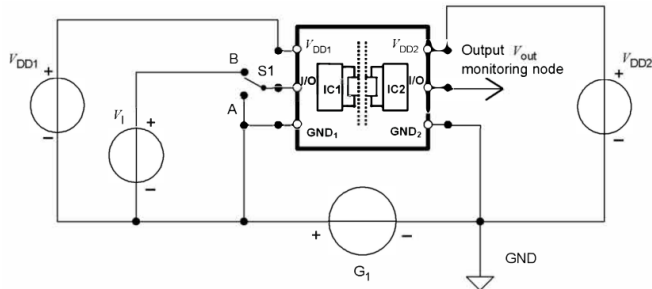

Figure 11. Common-mode transient immunity (CMTI) measurement

To measure the Common-Mode Transient Immunity (CMTI) of ISO7221 isolator under specified common-mode pulse magnitude (VCM) and specified slew rate of the common-mode pulse (dVCM/dt) and other specified test or ambient conditions, The common-mode pulse generator (G1) will be capable of providing fast rise and fall pulses of specified magnitude and duration of the common-mode pulse (VCM), such that the maximum common-mode slew rates (dVCM/dt) can be applied to ISO7221 isolator coupler under measurement. The common-mode pulse is applied between one side ground GND_1 and the other side ground GND_2 of ISO7221 isolator, and shall be capable of providing positive transients as well as negative transients.

OUTLINE DIMENSIONS

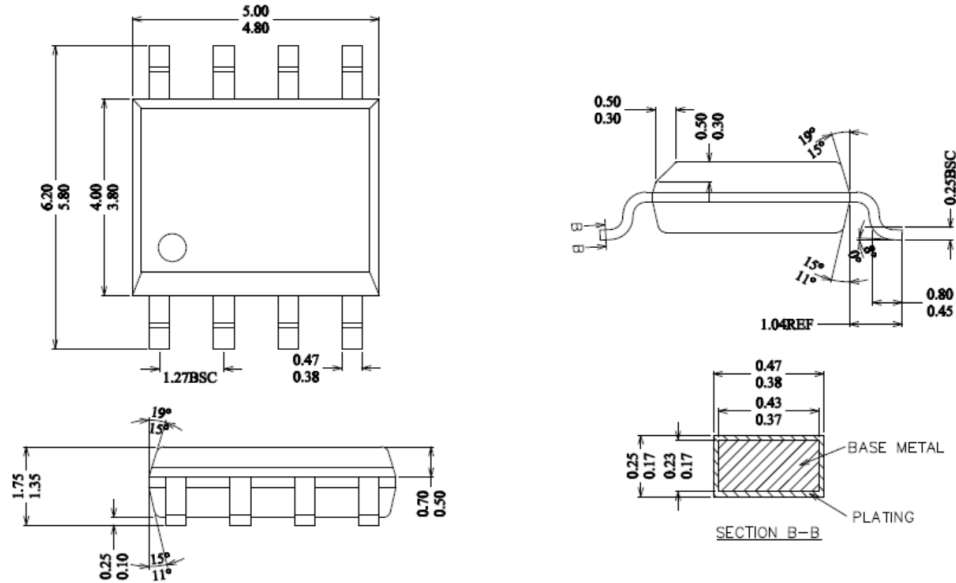

Figure 12. 8-Lead Narrow Body SOIC [NB SOIC-8] Package—dimension unit(mm)

Land Patterns

8-Lead Narrow Body SOIC [NB SOIC-8]

The figure below illustrates the recommended land pattern details for the ISO7221 in an 8-pin narrow-body SOIC. The table below lists the values for the dimensions shown in the illustration.

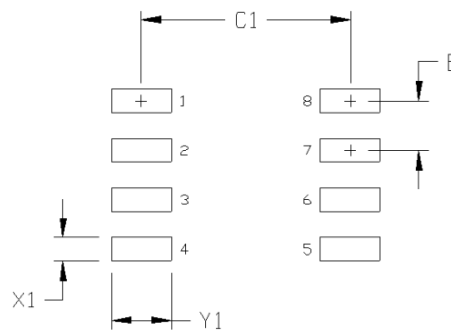

Figure 13.8-Lead Narrow Body SOIC [NB SOIC-8] Land Pattern

Table 13.8-Lead Narrow Body SOIC Land Pattern Dimensions

Dimension	Feature	Parameter	Unit
C1	Pad column spacing	5.40	mm
E	Pad row pitch	1.27	mm
X1	Pad width	0.60	mm
Y1	Pad length	1.55	mm

Note:

- 1.This land pattern design is based on IPC -7351.
- 2.All feature sizes shown are at maximum material condition and a card fabrication tolerance of 0.05 mm is assumed.

REEL INFORMATION

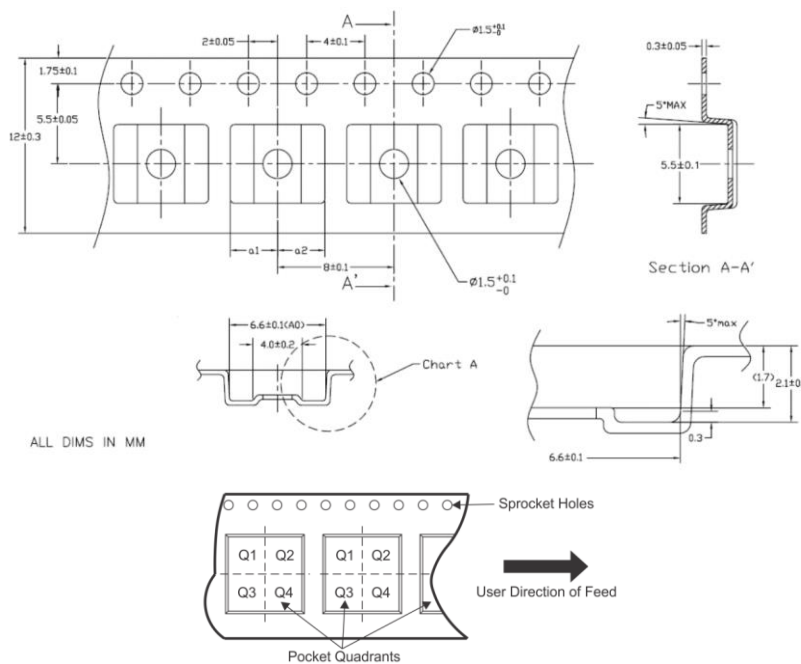

Note: The Pin 1of the chip is in the quadrant Q1

Figure 14.NB SOIC-8 Reel Information–dimension unit(mm)

ORDERING GUIDE

Model Name ¹	Temperature Range	No. of Inputs, V _{DD1} Side	No. of Inputs, V _{DD2} Side	Withstand Voltage Rating (kV rms)	Fail-Safe Output State	Package Description	MSL Peak Temp ²	Quantity per reel
ISO7221ADR	-40~125°C	1	0	3	High	NB SOIC-8	Level-2-260C-1 YEAR	4000
ISO7221ADQ	-40~125°C	1	0	3	High	NB SOIC-8	Level-2-260C-1 YEAR	4000
ISO7222ADR	-40~125°C	1	0	3	Low	NB SOIC-8	Level-2-260C-1 YEAR	4000
ISO7222ADQ	-40~125°C	1	0	3	Low	NB SOIC-8	Level-2-260C-1 YEAR	4000