

TL431 DATASHEET

Specification Revision History:

Version	Date	Description
V1.0	2019/12	New
V1.1	2021/01	Modify Ordering Information
V1.2	2025/02	Modify Ordering Information
V1.3	2025/03	Add application precautions and overall typesetting.
V1.4	2026/05	Add Simplified outline

FEATURES

- Equivalent Full Range Temperature Coefficient 50PPM/°C
- Temperature Compensated For Operation Over Full Rate Operating Temperature Range
- Adjustable Output Voltage
- Fast Turn-on Response
- Sink Current Capability 1mA to 100mA
- Low(0.27ΩTyp.)Dynamic Output Impedance
- Low Output Noise

DESCRIPTION

The 431 is three-terminal adjustable shunt regulator with specified thermal stability. The output voltage may be set to any value between VREF(Approx.2.495V)and 36Vwith two external resistors. This device has a typical output impedance of 0.2Ω. Active output circuitry provides a very sharp tum-on characteristic, making this device excellent replacement for zener diodes in many application

THE APPEARANCE OF THE PRODUCT



SOT-23

ORDERING INFORMATION

Product Model	Package Type	Marking	Packing	Packing Qty
TL431AR	SOT-23	431	REEL	3000PCS/REEL

SIMPLIFIED OUTLINE

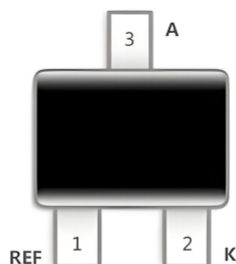

FUNCTION BLOCK DIAGRAM

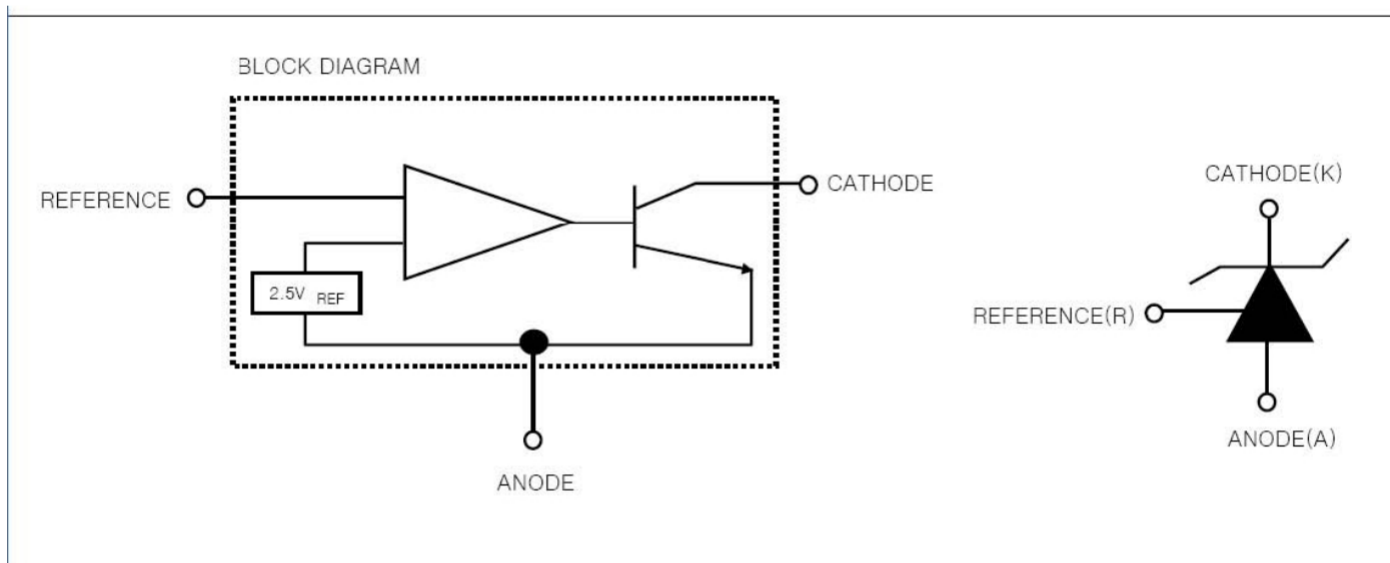

ABSOLUTE MAXIMUM RATINGS

(Full Operating Ambient Temperature Range Applies Unless Otherwise Noted)

CHARACTERISTIC	SYMBOL	RATING	UNIT
Cathode Voltage	V_{KA}	40	V
Continuous Cathode Current Range	I_{KA}	-100~+150	mA
Reference Input Current Range	I_{REF}	0.05~10	mA
Junction Temperature	T_J	150	°C
Operating Temperature	T_{ORR}	-20~85	°C
Storage Temperature	T_{STG}	-65~150	°C
Total Power Dissipation	P_D	700	mW

ELECTRICAL CHARACTERISTICS

($T_a=25^{\circ}\text{C}$, $V_{KA}=V_{REF}$, $I_K=10\text{mA}$ unless otherwise specified)

Characteristic	Symbol	Test Condition	Min	Typ	Max	Unit
Reference Input Voltage	V_{REF}	$V_{KA}=V_{REF}, I_g=10\text{mA}$	2.483	2.495	2.507	V
Deviation of Reference Input Voltage Over Full Temperature Range	$V_{REF(\text{dev})}$	$T_{\text{min}} \leq T_a \leq T_{\text{max}}$		3	17	mV
Ratio of Change in Reference Input Voltage to the Change in Cathode Voltage	$\Delta V_{REF}/\Delta V_{KA}$	$\Delta V_{KA}=10\text{V}-V_{REF}$ $\Delta V_{KA}=36\text{V}-10\text{V}$	-0.4 -0.4	0.0 0.0	2.7 2.0	mV/V
Reference Input Current	I_{REF}	$R_1=10\text{K}\Omega, R_2=\infty$		1.8	4	μA
Deviation of Reference Input Current Over Full Temperature Range	$I_{REF(\text{dev})}$	$R_1=10\text{K}\Omega, R_2=\infty$		0.4	1.2	μA
Minimum Cathode Current for Regulation	$I_{K(\text{min})}$			0.25	0.5	mA
Off-State Cathode Current	$I_{K(\text{OFF})}$	$V_{KA}=40\text{V}, V_{REF}=0$		0.17	0.9	μA
Dynamic Impedance	Z_{KA}	$I_K=10\text{mA to }100\text{mA}, f \leq 1.0\text{KHz}$		0.27	0.5	Ω

Fig. 1 Test Circuit for $V_{KA}=V_{REF}$

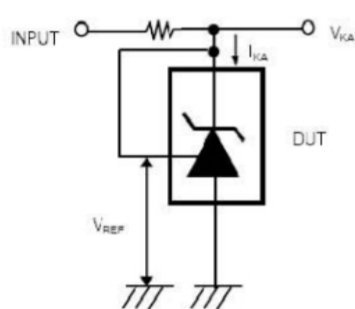

Fig. 2 Test Circuit for $V_{KA} \geq V_{REF}$

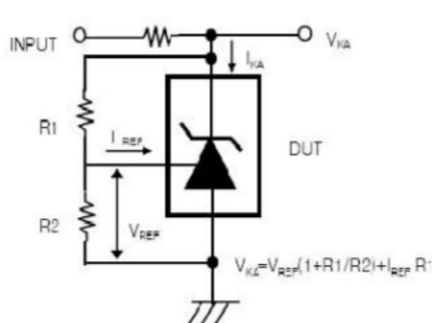
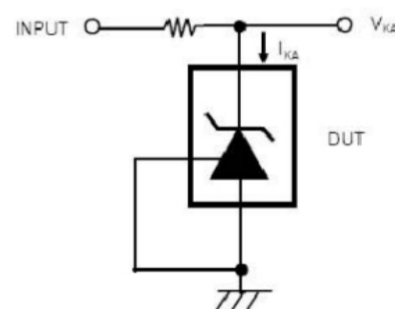
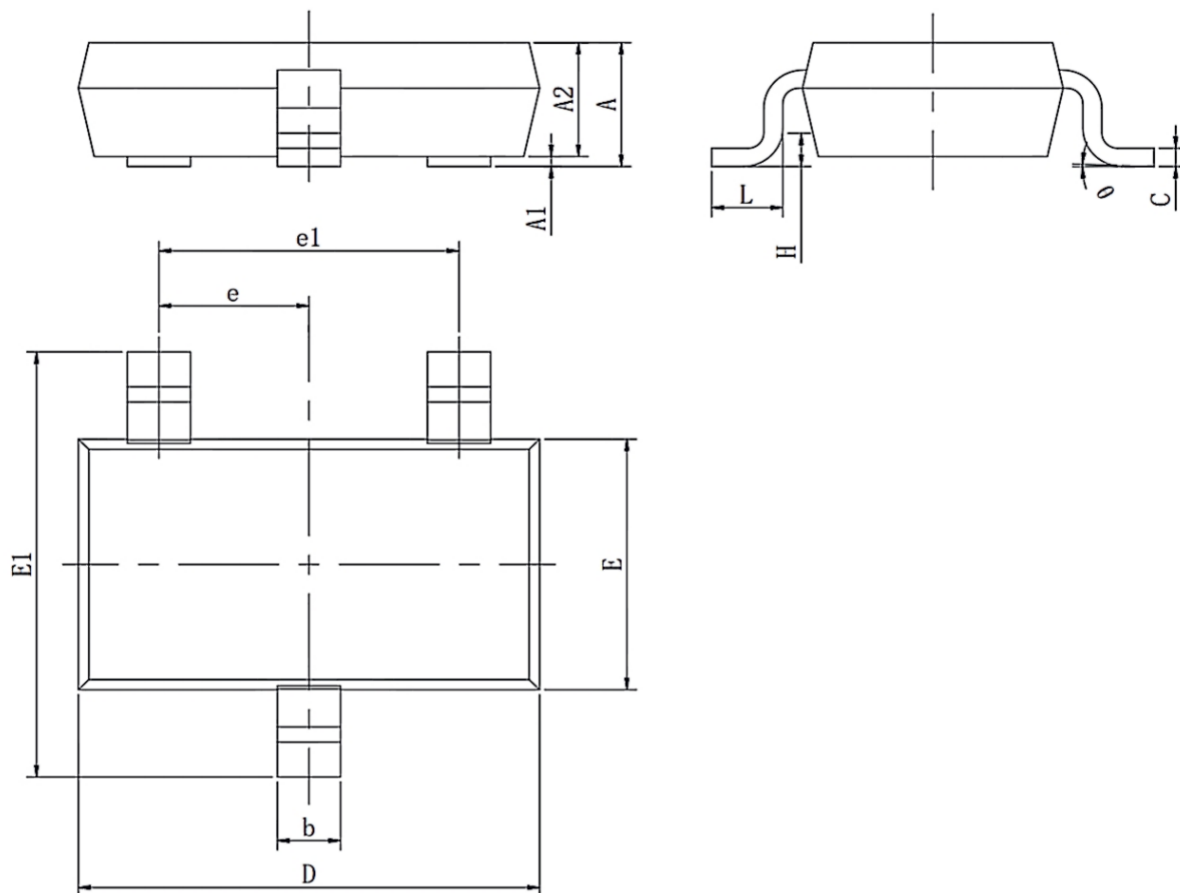

Fig. 3 Test Circuit for $I_{KA}(\text{off})$



OUTLINE DIMENSIONS

SOT-23



Symbol	Dimensions In Millimeters		Dimensions In Inches	
	Min	Max	Min	Max
A	0.900	1.150	0.035	0.045
A1	0.000	0.100	0.000	0.004
A2	0.900	1.050	0.035	0.041
b	0.300	0.500	0.012	0.020
C	0.080	0.200	0.003	0.008
D	2.800	3.020	0.110	0.119
E	1.200	1.400	0.047	0.055
E1	2.250	2.550	0.089	0.100
e	0.95 (BSC)		0.037(BSC)	
e1	1.90 (BSC)		0.075(BSC)	
L	0.300	0.500	0.012	0.020
θ	0°	8°	0°	8°

IMPORTANT NOTICE

- Green Micro chip reserves the right to change products and documents without notice. Customers should obtain and verify the completeness of the latest technical information before placing orders. Meanwhile, Green Micro chip shall not assume any responsibility or obligation for non-officially revised documents.
- Any parameters in the entire product specification are for reference only, and actual application testing shall prevail. When customers use the products for system design, they must comply with safety regulations and independently assume the following responsibilities: selecting suitable Green Micro chip products according to application requirements; completing design verification and full-link testing of the application; and ensuring that the application complies with safety regulations or other requirements of the target market. Customers shall bear all personal or property losses caused by design defects or illegal operations, which shall have no relation to Green Micro chip.
- Green Micro chip products are prohibited from being used in scenarios such as life support, military equipment, and key aerospace applications. All accidents and legal liabilities arising from out-of-scope use shall be borne by the user, and Green Micro chip shall not be held responsible.
- All technical resources of Green Micro chip (including data sheets and reference designs) are provided "as is", without guarantee of no defects or universality, and without any express or implied warranties. The documents are only authorized for product development and research described in this document. Unauthorized use of intellectual property, public reproduction, and reverse engineering are strictly prohibited. All claims and losses caused by illegal use shall be borne by the user, and Green Micro chip shall not be liable.