

## High Speed Optocoupler, Dual Channel, 10 MBd

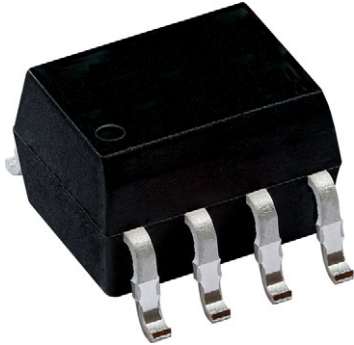

### DESCRIPTION

The VO0630, VO0631, VO0661 are dual channel 10 MBd optocoupler utilizing a high efficient input LED coupled to a high speed integrated photo-detector logic gate. The detector features an open drain output. The internal shield provides a guaranteed common mode transient immunity of up to 15 kV/ $\mu$ s.

### FEATURES

- CMTI of 15 kV/ $\mu$ s (min.)
- LVTTTL/LVCMOS compatibility
- Low power consumption
- Material categorization:  
for definitions of compliance please see [www.vishay.com/doc?99912](http://www.vishay.com/doc?99912)



**RoHS**  
COMPLIANT

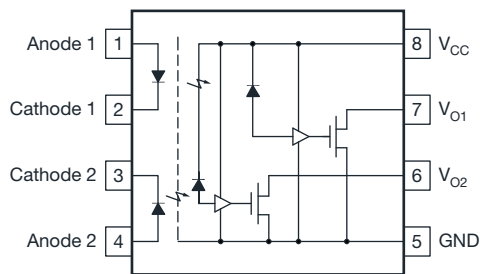

### APPLICATIONS

- Microprocessor system interface
- Ground loop elimination
- Digital bus systems isolation
- High speed A/D and D/A conversion
- Digital control power supply
- Level shifting

### AGENCY APPROVALS

- [UL1577](#)
- [cUL](#)
- [DIN EN 60747-5-5 \(VDE 0884-5\), available with option 1](#)

### LINKS TO ADDITIONAL RESOURCES





ORDERING INFORMATION				
<div style="display: flex; justify-content: space-around; align-items: center;"> <div style="border: 1px solid black; padding: 2px 5px;">V</div> <div style="border: 1px solid black; padding: 2px 5px;">O</div> <div style="border: 1px solid black; padding: 2px 5px;">0</div> <div style="border: 1px solid black; padding: 2px 5px;">6</div> <div style="border: 1px solid black; padding: 2px 5px;">#</div> <div style="border: 1px solid black; padding: 2px 5px;">#</div> <div style="border: 1px solid black; padding: 2px 5px;">-</div> <div style="border: 1px solid black; padding: 2px 5px;">X</div> <div style="border: 1px solid black; padding: 2px 5px;">0</div> <div style="border: 1px solid black; padding: 2px 5px;">0</div> <div style="border: 1px solid black; padding: 2px 5px;">#</div> <div style="border: 1px solid black; padding: 2px 5px;">T</div> </div>	PART NUMBER		PACKAGE OPTION	Tape and Reel
AGENCY CERTIFIED / PACKAGE		CMR (kV/μs)		
UL, cUL	1	5	15	
SOIC-8	VO0630T	VO0631T	VO0661T	
UL, cUL, VDE (option 1)	1	5	15	
SOIC-8	-	VO0631-X001T	-	

Note

- Additional options may be possible, please contact sales office

ABSOLUTE MAXIMUM RATINGS (T <sub>amb</sub> = 25 °C, unless otherwise specified)				
PARAMETER	TEST CONDITION	SYMBOL	VALUE	UNIT
<b>INPUT</b>				
Input forward current		I <sub>F</sub>	15	mA
Peak transient input current	> 1 μs pulse width, 330 pps	I <sub>F(tran)</sub>	1.0	A
Reverse input voltage		V <sub>R</sub>	5	V
Input power dissipation		P <sub>diss</sub>	40	mW
<b>OUTPUT</b>				
Supply voltage		V <sub>CC</sub>	7	V
Output current		I <sub>O</sub>	50	mA
Output voltage		V <sub>O</sub>	7	V
Output power dissipation		P <sub>diss</sub>	60	mW
<b>COUPLER</b>				
Storage temperature		T <sub>stg</sub>	-55 to +125	°C
Operating temperature		T <sub>amb</sub>	-40 to +100	°C
Solder reflow temperature <sup>(1)</sup>	5 s		260	°C

Notes

- Stresses in excess of the absolute maximum ratings can cause permanent damage to the device. Functional operation of the device is not implied at these or any other conditions in excess of those given in the operational sections of this document. Exposure to absolute maximum ratings for extended periods of the time can adversely affect reliability.
- <sup>(1)</sup> Refer to reflow profile for soldering conditions for surface mounted devices (SMD). Refer to wave profile for soldering conditions for through hole devices (DIP).

RECOMMENDED OPERATING CONDITIONS				
PARAMETER	SYMBOL	MIN.	MAX.	UNIT
Operating temperature	T <sub>amb</sub>	-40	+100	°C
Supply voltage	V <sub>CC</sub>	4.5	5.5	V
Input current low level	I <sub>FL</sub>	0	250	μA
Input current high level	I <sub>FH</sub>	5	15	mA
Output pull up resistor	R <sub>L</sub>	330	4000	Ω
Fanout (R <sub>L</sub> = 1 kΩ)	N	-	5	TTL loads

TRUTH TABLE (positive logic)	
LED	OUTPUT
On	L
Off	H

<b>ELECTRICAL CHARACTERISTICS</b> ( $T_{amb} = -40\text{ }^{\circ}\text{C}$ to $+100\text{ }^{\circ}\text{C}$ , $4.5\text{ V} \leq V_{CC} \leq 5.5\text{ V}$ , $I_F = 7.5\text{ mA}$ , unless otherwise specified; typical values are at $V_{CC} = 5.0\text{ V}$ , $T_{amb} = 25\text{ }^{\circ}\text{C}$ )						
PARAMETER	TEST CONDITION	SYMBOL	MIN.	TYP.	MAX.	UNIT
<b>INPUT</b>						
Input forward voltage	$I_F = 10\text{ mA}$	$V_F$	-	1.38	1.70	V
Input forward voltage temperature coefficient	$I_F = 10\text{ mA}$	$\Delta V_F / \Delta T$	-	-1.5	-	mV/K
Input reverse voltage	$I_R = 10\text{ }\mu\text{A}$	$BV_R$	5	-	-	V
Input threshold current	$V_O = 0.6\text{ V}$ , $V_{CC} = 5.5\text{ V}$ , $I_{OL}$ (sinking) = 13 mA	$I_{TH}$	-	2.1	5	mA
Input capacitance	$f = 1\text{ MHz}$ , $V_F = 0\text{ V}$	$C_I$	-	34	-	pF
<b>OUTPUT</b>						
Low level supply current	$I_F = 10\text{ mA}$ , $V_{CC} = 5.5\text{ V}$	$I_{CCL}$	-	7.2	10	mA
High level supply current	$I_F = 0\text{ mA}$ , $V_{CC} = 5.5\text{ V}$	$I_{CCH}$	-	7.6	10	mA
Low level output voltage	$V_{CC} = 5.5\text{ V}$ , $I_F = 5\text{ mA}$ , $I_{OL}$ (sinking) = 13 mA	$V_{OL}$	-	0.09	0.60	V
High level output current	$V_{CC} = 5.5\text{ V}$ , $V_O = 5.5\text{ V}$ , $I_F = 250\text{ }\mu\text{A}$	$I_{OH}$	-	1	10	$\mu\text{A}$
<b>COUPLER</b>						
Input to output capacitance	$f = 1\text{ MHz}$ , $T_{amb} = 25\text{ }^{\circ}\text{C}$	$C_{IO}$	-	1	-	pF

**Note**

- Minimum and maximum values are testing requirements. Typical values are characteristics of the device and are the result of engineering evaluation. Typical values are for information only and are not part of the testing requirements.

<b>SWITCHING CHARACTERISTICS</b> ( $T_{amb} = -40\text{ }^{\circ}\text{C}$ to $+100\text{ }^{\circ}\text{C}$ , $4.5\text{ V} \leq V_{CC} \leq 5.5\text{ V}$ , $I_F = 7.5\text{ mA}$ , unless otherwise specified; typical values are at $V_{CC} = 5.0\text{ V}$ , $T_{amb} = 25\text{ }^{\circ}\text{C}$ )						
PARAMETER	TEST CONDITION	SYMBOL	MIN.	TYP.	MAX.	UNIT
Propagation delay time to high output level	$R_L = 350\text{ }\Omega$ , $C_L = 15\text{ pF}$ , $T_{amb} = 25\text{ }^{\circ}\text{C}$	$t_{PLH}$	25	50	90	ns
	$R_L = 350\text{ }\Omega$ , $C_L = 15\text{ pF}$	$t_{PLH}$	-	-	100	ns
Propagation delay time to low output level	$R_L = 350\text{ }\Omega$ , $C_L = 15\text{ pF}$ , $T_{amb} = 25\text{ }^{\circ}\text{C}$	$t_{PHL}$	25	40	75	ns
	$R_L = 350\text{ }\Omega$ , $C_L = 15\text{ pF}$	$t_{PHL}$	-	-	100	ns
Pulse width distortion	$R_L = 350\text{ }\Omega$ , $C_L = 15\text{ pF}$	$ t_{PLH} - t_{PHL} $	-	10	-	ns
Propagation delay skew	$R_L = 350\text{ }\Omega$ , $C_L = 15\text{ pF}$	$t_{PSK}$	-	-	40	ns
Output rise time (10 % to 90 %)	$R_L = 350\text{ }\Omega$ , $C_L = 15\text{ pF}$	$t_r$	-	11	-	ns
Output fall time (90 % to 10 %)	$R_L = 350\text{ }\Omega$ , $C_L = 15\text{ pF}$	$t_f$	-	2.3	-	ns

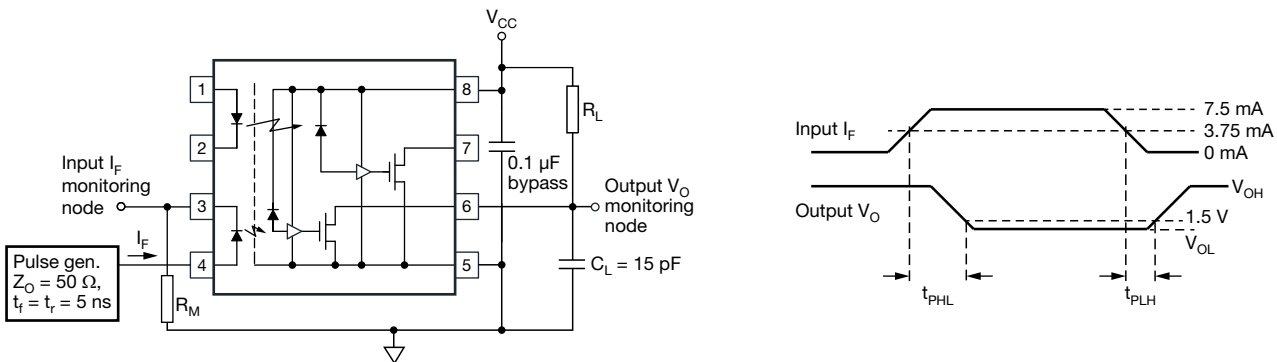

The probe and Jig capacitances are included in  $C_L$

Fig. 1 - Test Circuit for  $t_{PLH}$ ,  $t_{PHL}$ ,  $t_r$ , and  $t_f$



**TYPICAL CHARACTERISTICS** ( $T_{amb} = 25\text{ }^{\circ}\text{C}$ , unless otherwise specified)

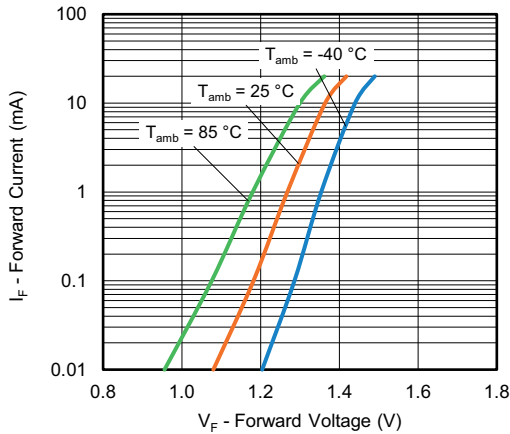

Fig. 3 - Forward Current vs. Forward Voltage

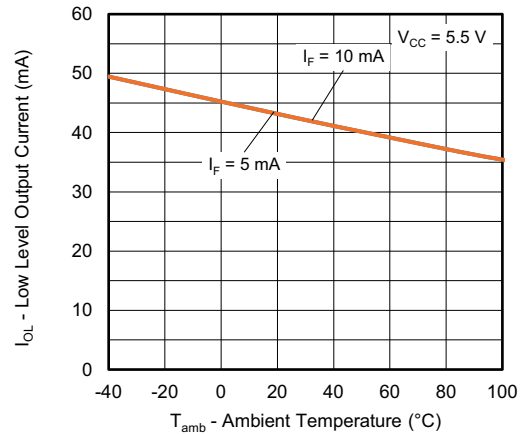

Fig. 6 - Low Level Output Current vs. Ambient Temperature

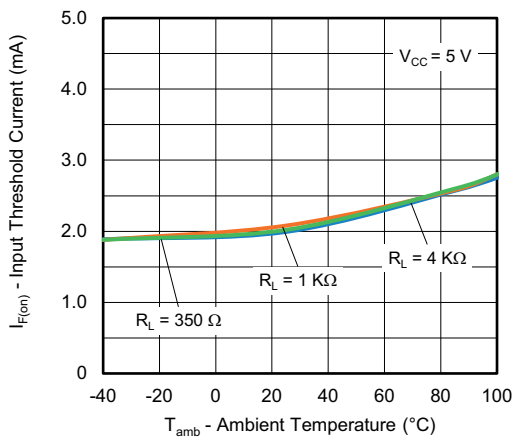

Fig. 4 - Input Threshold Current vs. Ambient Temperature

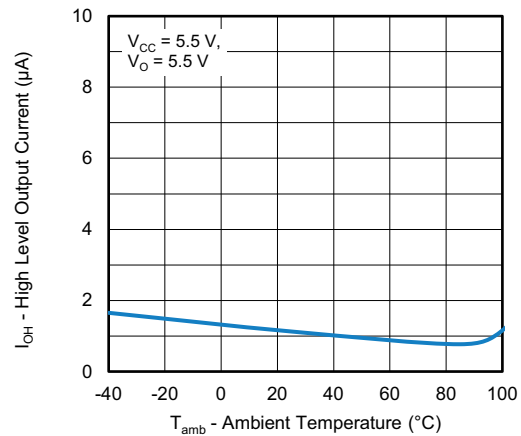

Fig. 7 - High Level Output Current vs. Ambient Temperature

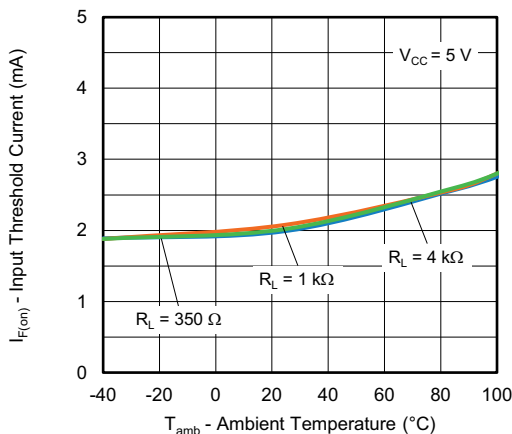

Fig. 5 - Low Level Output Voltage vs. Ambient Temperature

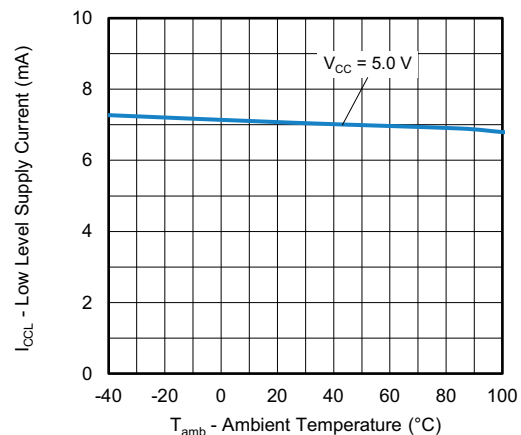

Fig. 8 - Low Level Supply Current vs. Ambient Temperature

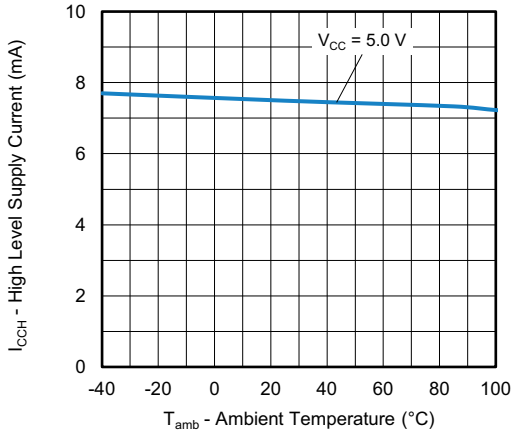

Fig. 9 - High Level Supply Current vs. Ambient Temperature

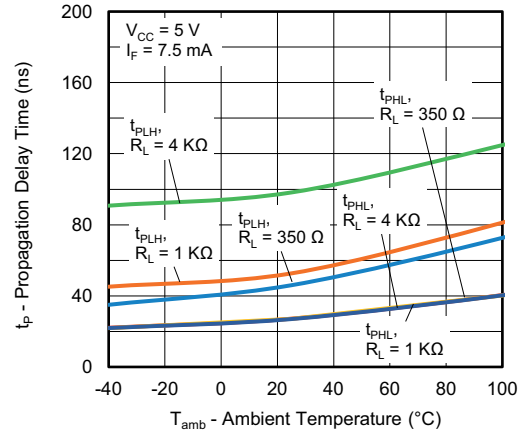

Fig. 11 - Propagation Delay Time vs. Ambient Temperature

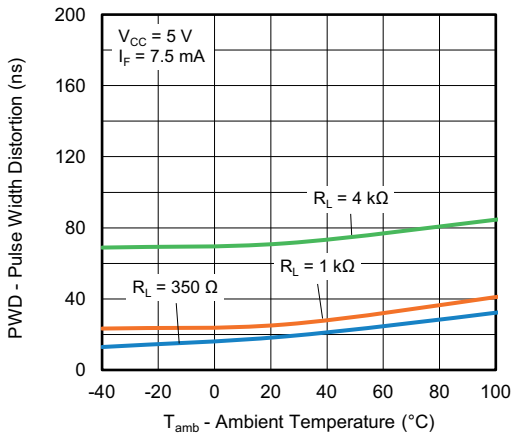

Fig. 10 - Pulse Width Distortion vs. Ambient Temperature

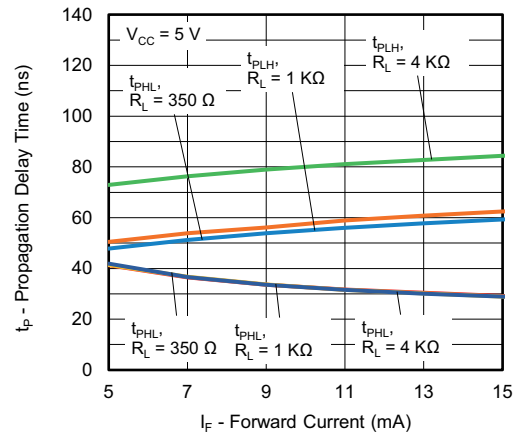

Fig. 12 - Propagation Delay Time vs. Forward Current



PACKAGE DIMENSIONS (in millimeters)

SOIC-8

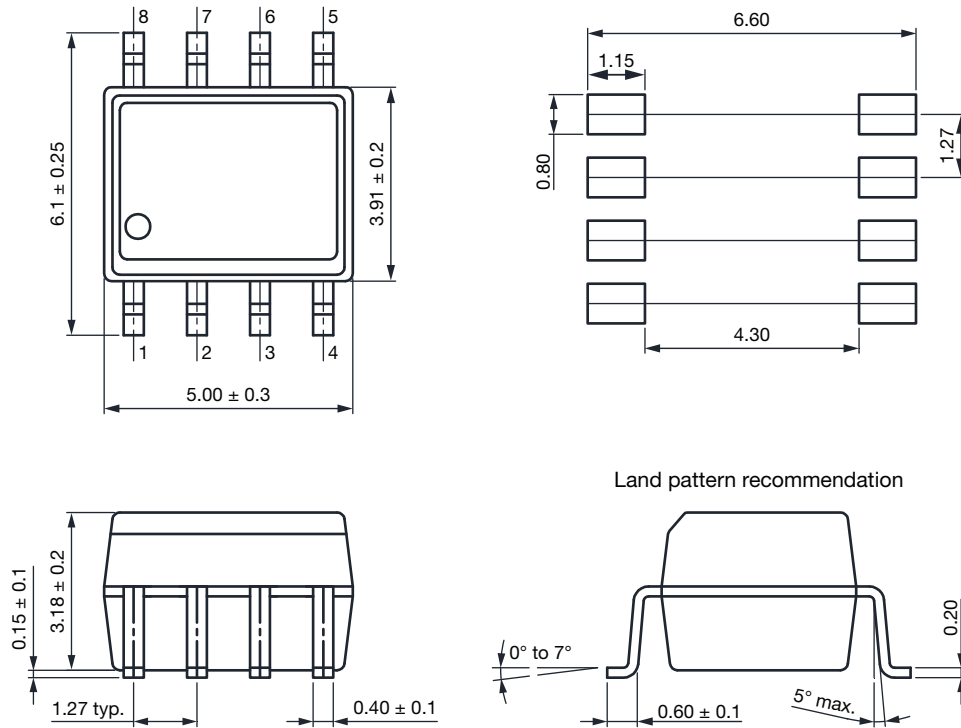

Fig. 13

PACKAGE MARKING

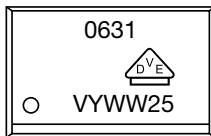

Fig. 14 - Example of VO0631-X001T

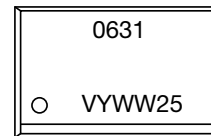

Fig. 15 - Example of VO0631T

Notes

- "YWW" is the date code marking (Y = year code, WW = week code)
- The VDE symbol is only marked on VDE option parts
- Tape and reel suffix (T) is not part of the package marking



PACKAGING INFORMATION (in millimeters)

SOIC-8 Tape

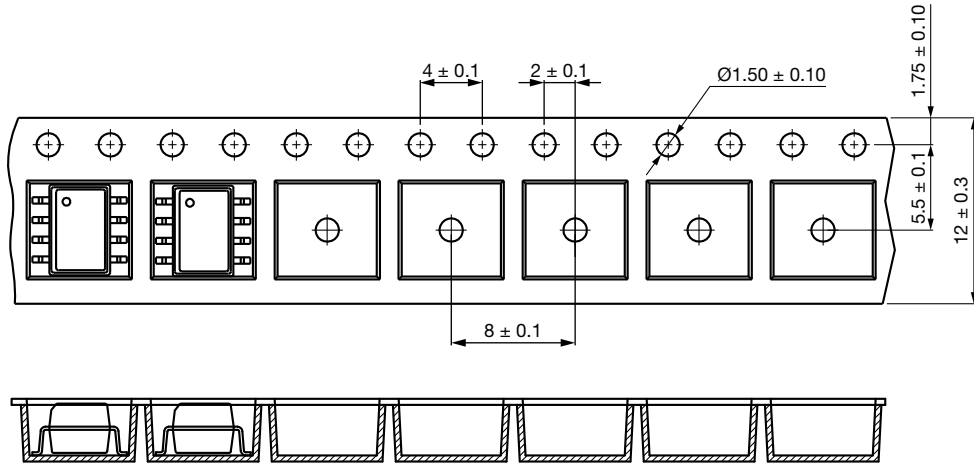

Fig. 16 - Tape and Reel Packaging (2000 pieces on reel)

Reel

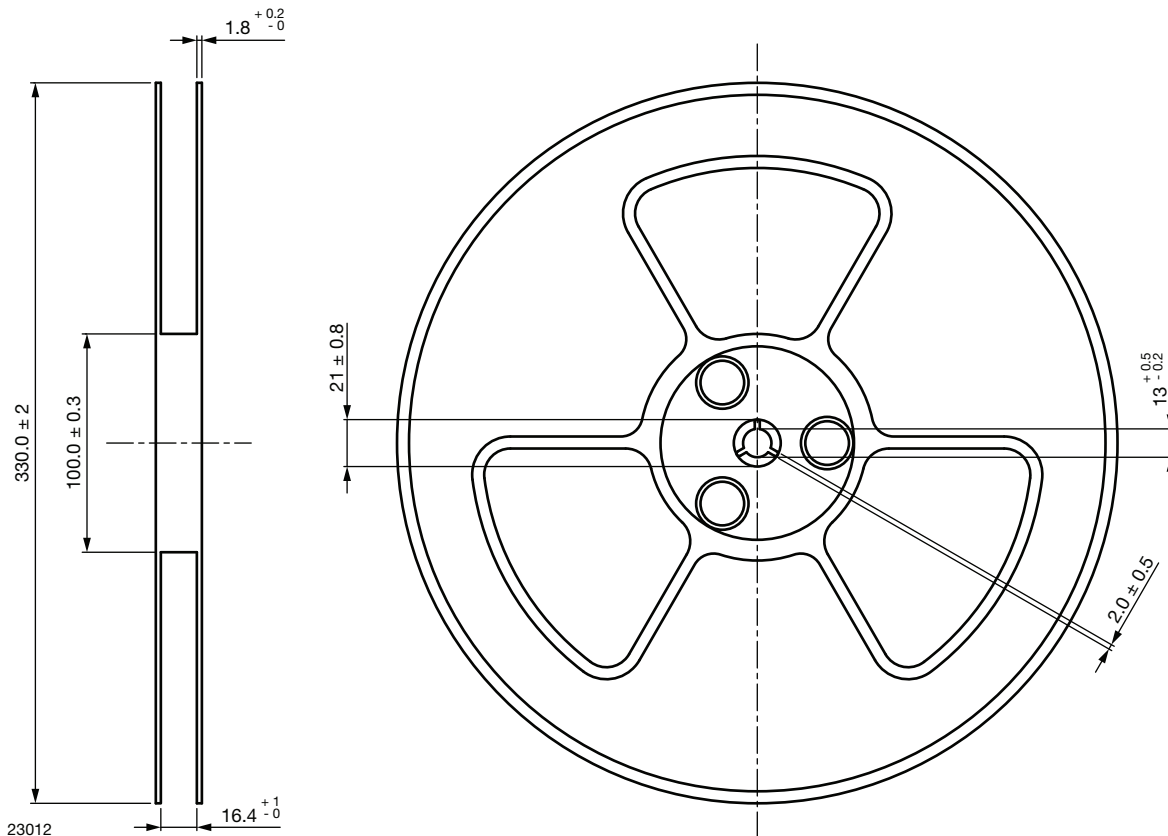

Fig. 17 - Tape and Reel Shipping Medium

**SOLDER PROFILES**
**IR Reflow Soldering (JEDEC® J-STD-020C compliant)**

One time soldering reflow is recommended within the condition of temperature and time profile shown below. Do not solder more than three times.

PROFILE ITEM	CONDITIONS
Preheat	
- Temperature minimum ( $T_{S \text{ min.}}$ )	150 °C
- Temperature maximum ( $T_{S \text{ max.}}$ )	200 °C
- Time (min. to max.) ( $t_s$ )	90 s ± 30 s
Soldering zone	
- Temperature ( $T_L$ )	217 °C
- Time ( $t_L$ )	60 s
Peak temperature ( $T_p$ )	260 °C
Ramp-up rate	3 °C/s max.
Ramp-down rate	3 °C/s to 6 °C/s

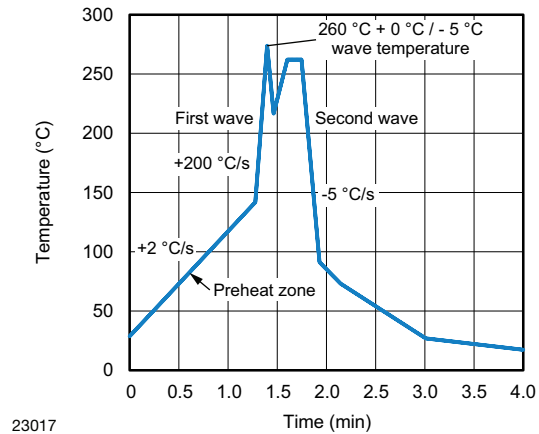

Fig. 19

**Hand Soldering by Soldering Iron**

Allow single lead soldering in every single process. One time soldering is recommended.

Temperature: 380 °C + 0 °C / - 5 °C

Time: 3 s max.

**HANDLING AND STORAGE CONDITIONS**

ESD level: HBM class 2

Floor life: unlimited

Conditions:  $T_{\text{amb}} < 30 \text{ °C}$ , RH < 85 %

Moisture sensitivity level 1, according to J-STD-020

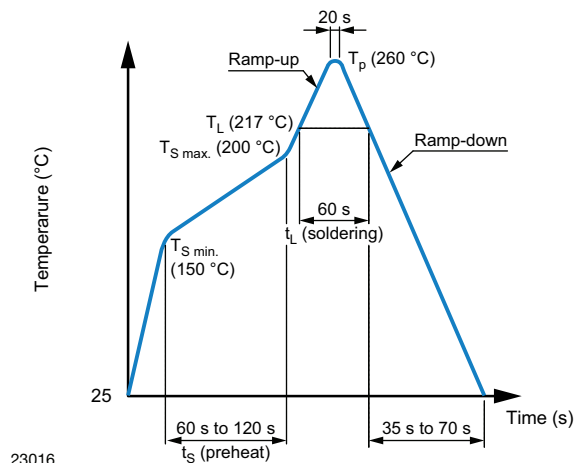

Fig. 18

**Wave Soldering (JEDEC JESD22-A111 compliant)**

One time soldering is recommended within the condition of temperature.

Temperature: 260 °C + 0 °C / - 5 °C

Time: 10 s

Preheat temperature: 25 °C to 140 °C

Preheat time: 30 s to 80 s



## Disclaimer

ALL PRODUCT, PRODUCT SPECIFICATIONS AND DATA ARE SUBJECT TO CHANGE WITHOUT NOTICE TO IMPROVE RELIABILITY, FUNCTION OR DESIGN OR OTHERWISE.

Vishay Intertechnology, Inc., its affiliates, agents, and employees, and all persons acting on its or their behalf (collectively, "Vishay"), disclaim any and all liability for any errors, inaccuracies or incompleteness contained in any datasheet or in any other disclosure relating to any product.

Vishay makes no warranty, representation or guarantee regarding the suitability of the products for any particular purpose or the continuing production of any product. To the maximum extent permitted by applicable law, Vishay disclaims (i) any and all liability arising out of the application or use of any product, (ii) any and all liability, including without limitation special, consequential or incidental damages, and (iii) any and all implied warranties, including warranties of fitness for particular purpose, non-infringement and merchantability.

Statements regarding the suitability of products for certain types of applications are based on Vishay's knowledge of typical requirements that are often placed on Vishay products in generic applications. Such statements are not binding statements about the suitability of products for a particular application. It is the customer's responsibility to validate that a particular product with the properties described in the product specification is suitable for use in a particular application. Parameters provided in datasheets and / or specifications may vary in different applications and performance may vary over time. All operating parameters, including typical parameters, must be validated for each customer application by the customer's technical experts. Product specifications do not expand or otherwise modify Vishay's terms and conditions of purchase, including but not limited to the warranty expressed therein.

Hyperlinks included in this datasheet may direct users to third-party websites. These links are provided as a convenience and for informational purposes only. Inclusion of these hyperlinks does not constitute an endorsement or an approval by Vishay of any of the products, services or opinions of the corporation, organization or individual associated with the third-party website. Vishay disclaims any and all liability and bears no responsibility for the accuracy, legality or content of the third-party website or for that of subsequent links.

Vishay products are not designed for use in life-saving or life-sustaining applications or any application in which the failure of the Vishay product could result in personal injury or death unless specifically qualified in writing by Vishay. Customers using or selling Vishay products not expressly indicated for use in such applications do so at their own risk. Please contact authorized Vishay personnel to obtain written terms and conditions regarding products designed for such applications.

No license, express or implied, by estoppel or otherwise, to any intellectual property rights is granted by this document or by any conduct of Vishay. Product names and markings noted herein may be trademarks of their respective owners.