

# 惠州市鑫永诚光电科技有限公司 Huizhou Newopto photoelectric Technology Co., Ltd.

## 产品承认书 SPEC FOR APPROVAL

客户名称 Customer	
产品型号 Model	XYC-ALS21C-K1
承认编号 Part No.	ALS298-A
编制日期 Edit Date	2023-07-20
版本 Edition	A1

核准(Approval)	审核(Check)	编制(Edit)
谭起富	丁杰	彭超

客户确认(Customer Signatures)		

地址：惠州市仲恺高新区潼侨镇宏村宏川路鑫永诚科技园

Address: Newopto Technology Zone, Hongchuan road, Hong village, Tongqiao town, Zhongkai High tech Zone, Huizhou city, Guangdong, China

电话(Tel): 0752—7987222

网址(Web site): <http://www.xycgd.com>

传真(Fax): 0752—7987000

邮箱(E-mail): [xycgd888@163.com](mailto:xycgd888@163.com)



XYC-ALS21C-K1 is a light to digital converter which combines photodiodes, current amplifiers, analog circuit and digital signal processor.

Ambient light sensor (ALS) built-in an optical filter for IR rejection, and providing a spectrum which is close to the human eye's response. ALS can work from dark to direct sunlight, the selectable detect range is about 40dB. Dual-channel output (human eye), so it has excellent light ratio under different light conditions. ALS has excellent light ratio under different light conditions.

XYC-ALS1206AC-K1 has programmable interrupt function with high / low threshold.

## Features

- I<sup>2</sup>C interface (Fast Speed Mode at 400kHz/s)
  - Dedicated Interrupt Pin
  - Supply Voltage Range from 1.7V to 3.6V
  - Operating Temperature Range from 40°C to +85°C
  - Ambient Light Sensor
  - AIS Channel
- Close to human eyes responsibility
  - Up to 16-bit Digital Output
  - Programmable Dynamic Range Ratio = x1 : x4 : x16: x64: x256
  - Linear Output Code for Dynamic Range Selection
  - Eliminate 50 / 60 Hz Filter by Programmable Integrated Time
  - Fluorescent light flicker immunity

## Applications

- TV Panel Control
- Smart Phone
- Accessories
- Industrial Control
- Lighting Control

**Block Diagram**

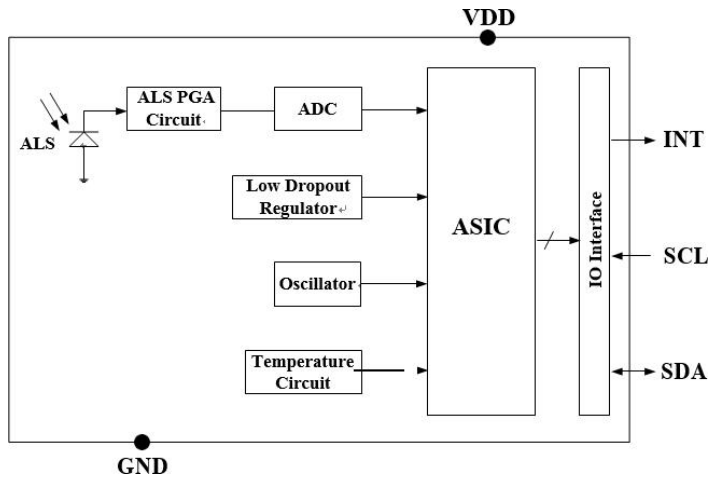
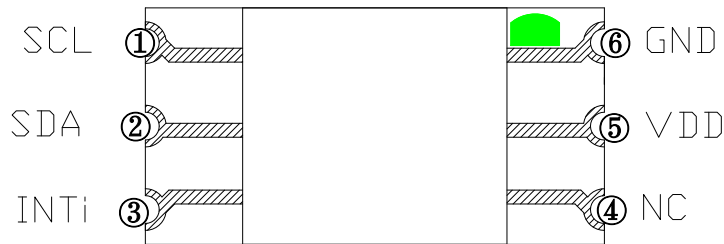

Fig. 1 Block Diagram

**I/O Pins Configuration**



Pad	I/O Type	Pad Name	Description
1	I	SCL	I <sup>2</sup> C serial clock line
2	I/O	SDA	I <sup>2</sup> C serial data line
3	O	INT	Interrupt pin
4	NC	/	/
5		VDD	Power supply
6		GND	Ground

**Absolute Maximum Ratings\***

Parameter	Symbol	Value	Unit
Supply Voltage	V <sub>DD</sub>	4.5	V
I <sup>2</sup> C Bus Pin Voltage	V <sub>SCL</sub> , V <sub>SDA</sub> , V <sub>INT</sub>	-0.2 to 4.5	V
I <sup>2</sup> C Bus Pin Current	I <sub>SCL</sub> , I <sub>SDA</sub> , I <sub>INT</sub>	10	mA
LDR Pin Voltage	V <sub>LEDC</sub>	-0.2V to VDD + 0.5V	V
Operating Temperature	T <sub>ope</sub>	-40 to +85	°C
Storage Temperature	T <sub>stg</sub>	-45 to +100	°C
ESD Rating	Human Body Mode	2	KV

\*Note : Exceeding these ratings could cause damage to the device. All voltages are with respect to ground. Currents are positive into, negative out of the specified terminal.

### Recommended Operation Conditions

Parameter	Symbol	Min.	Typ.	Max.	Unit	Condition
Supply Voltage <sup>Note1,2</sup>	$V_{DD}$	1.7		3.6	V	
I <sup>2</sup> C Bus Pin Voltage <sup>Note2</sup>	$V_{Bus}$		VDD			VDD=VBUS
Operating Temperature	$T_{ope}$	-40		+85	°C	
I <sup>2</sup> C Bus Input High Voltage <sup>Note2</sup>	$V_{IH\_SCL},$ $V_{IH\_SDA}$	VDD *0.7			V	
I <sup>2</sup> C Bus Input Low Voltage <sup>Note2</sup>	$V_{IL\_SCL},$ $V_{IL\_SDA}$			VDD *0.3	V	
SDA Output Low Voltage	$V_{OL\_SDA}$	0		0.4	V	3mA sinking current
		0		0.6	V	6mA sinking current
INT Output Low Voltage	$V_{OL\_INT}$	0		0.4	V	3mA sinking current

Notes:

1. The power supply need to make sure the VDD slew rate at least 0.5V/ms. XYC-ALS1206AC-K1 have power on reset function. When VDD drops below 1.4V under room temp, the IC will be reset automatically. Then power back up at the requirement slew rate, and write registers to the desired values.
2. The IC power supply sequence is shown in below
3. The specs are defined under VDD=3.3V, T=25°C

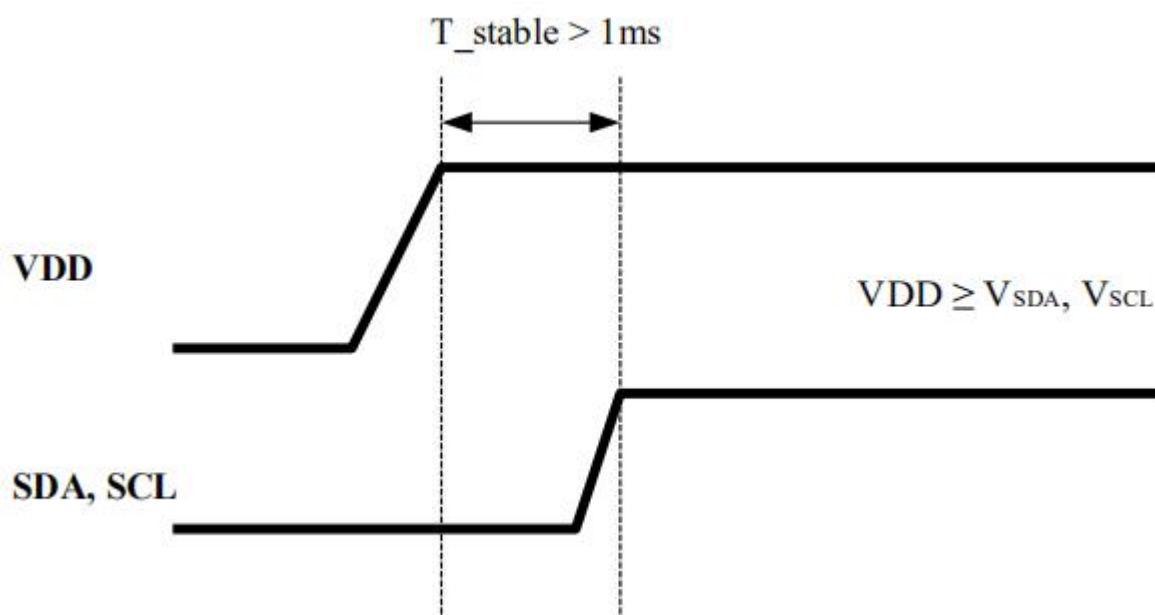

## Electrical & Optical Specifications

Unless otherwise specified, the following specifications apply over the operating ambient temperature  $T=25^{\circ}\text{C}$ ,  $V_{DD} = 3.3\text{V}$ , and measure the output current by white light LED.

Electrical Characteristics	Symbol	MIN	TYP	MAX	Notes	Unit
Active Supply Current	$I_{DD1}$		39		Ev=0 , Note 1	$\mu\text{A}$
	$I_{DD2}$		7		Ev=0 , Note 2	$\mu\text{A}$
	$I_{PD}$		1.5		Sleep mode ,Ev=0, Brown out disable	$\mu\text{A}$
Device Boot Time	$T_{boot}$		20		Note 3	ms

Notes :

1. ALS\_CONV=1, INTE\_TIME=64, WUNIT=1T(8ms), WSTEP=64
2. ALS\_CONV=1, INTE\_TIME=64, WUNIT=8T(64ms), WSTEP=62
3. The Device Boot Time ( $T_{boot}$ ) is the delay time that the host can send the first I2C command after the VDD ready

ALS Characteristics	Symbol	MIN	TYP	MAX	Notes	Unit
Sensing Gain, relative to x1 setting	AGAIN		4/16/64/256			
ALS ADC integration time step size			1.17			ms
ALS ADC number of integration unit	ALS_CONV	1		16		unit
ALS ADC number of integration steps	INTE_TIME	1		64		step
Full scale ADC counts per step				1023		count
Full scale ADC counts value				65535		count
Dark count(white LED, Ev=0 lux)	ALS_L		0	5	AGAIN=256 ATIME=64	count
ALS ADC count value (white LED , Ev=100lux)	ALS_L		10880		AGAIN=256 ATIME=64	count
ALS ADC count value (white LED , Ev=100lux)	ALS_L		216		AGAIN=256 ATIME=64 2 * INTE_TIME	Count/lux
Digital Resolution			0.0069		IT=100ms , AGAIN=256	Lux/count
Detectable Min. Illuminance			0.004		IT=100ms , AGAIN=256	lux
Detectable Max. Illuminance			110000		IT=100ms , AGAIN=1~256	lux

## State Machine

There is one prime operation mode ALS. The state machine is shown below:

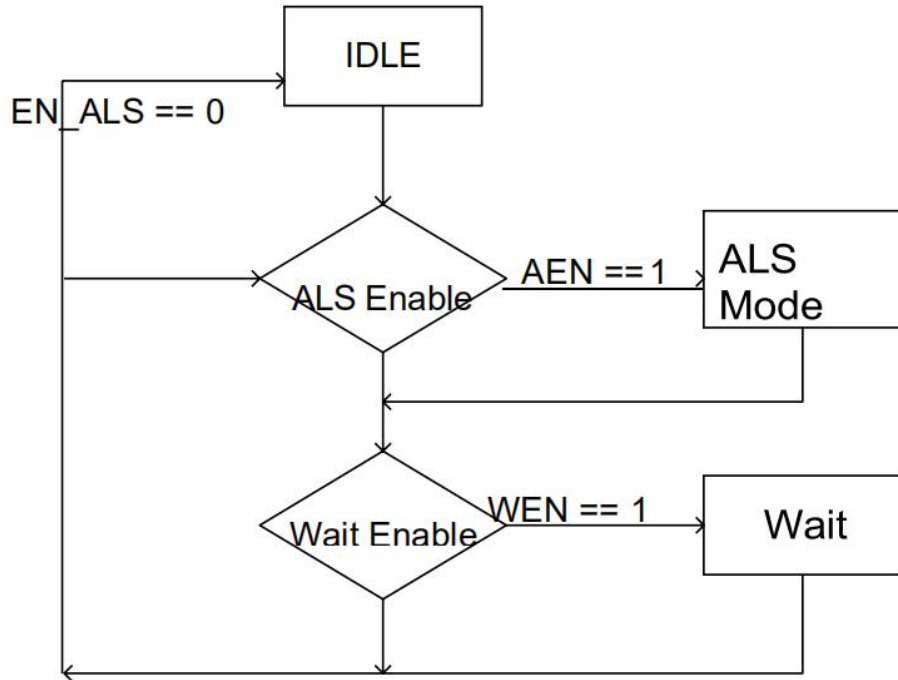

## Typical Characteristics Curves

Unless otherwise specified, the following specifications apply over the operating ambient temperature  $T = 25^{\circ}\text{C}$ ,  $VDD = 3.3\text{V}$ .

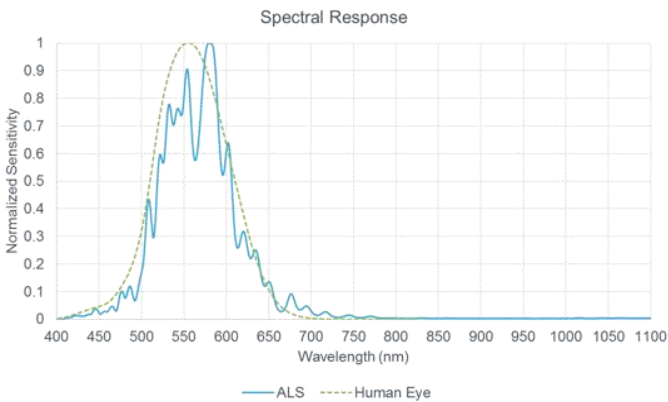

Fig. 1 Spectral Response

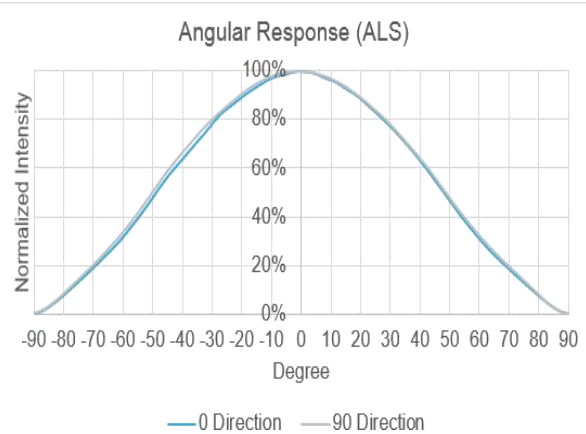
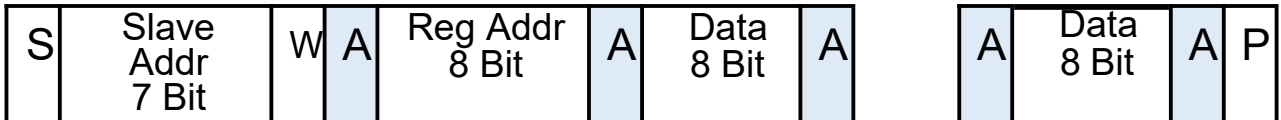

Fig. 2 Angular Response

**I<sup>2</sup>C Write**



**I<sup>2</sup>CBlock Write**



**I<sup>2</sup>CRead**

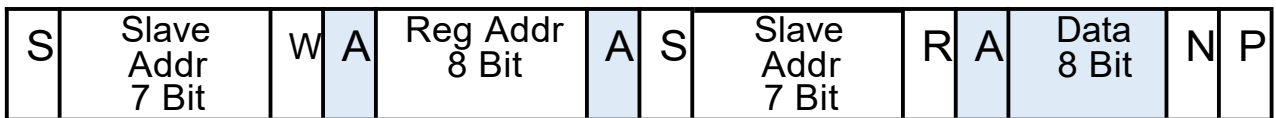

**I<sup>2</sup>CBlock Read**

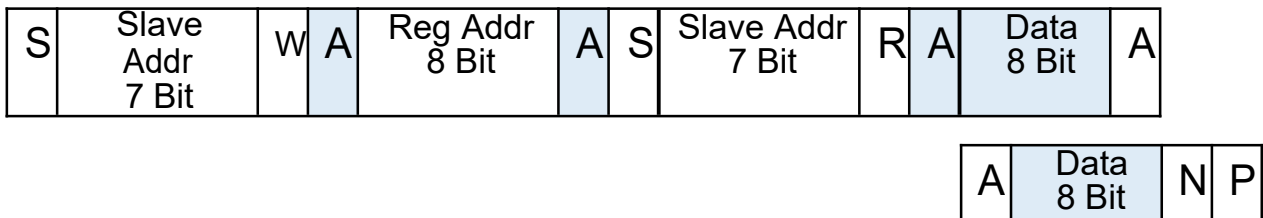

Master to

Slave to

Master

- Start Condition, 1
- Bit Stop Condition,
- 1 Bit
- Write, Set 0 for write, 1 Bit
- Read, Set 1 for read, 1 Bit
- Acknowledge(ACK), Set 0,
- 1 Bit
- Non acknowledge(NACK), Set 1, 1 Bit

## I<sup>2</sup>C Slave Address and R/W bit

This address is seven bits long followed by an eighth bit which is a data direction bit (R/W). A '0' indicates a transmission (WRITE), a '1' indicates a request for data (READ). The slave address of this device is 0x38.

## Register Set

The XYC-ALS1206AC-K1 is operated over the I2C bus with registers that contain configuration, status, and result information. All registers are 8 bits long.

Address	Name	Type	Default value	Description
0x00	SYSM_CTRL	R/W	0x0	ALS/PS/CALIB operation mode control, waiting mode control, SW reset
0x01	INT_CTRL	R/W	0x01	Interrupt pin control, interrupt persist control
0x02	INT_FLAG	R/W	0x00	Interrupt flag, error flag, power on reset(POR) flag
0x03	WAIT_TIME	R/W	0x00	Waiting time setting
0x04	ALS_GAIN	R/W	0x01	ALS analog gain setting
0x05	ALS_TIME	R/W	0x03	ALS integrated time setting
0x0B	PERSISTENCE	R/W	0x01	ALS persistence setting
0x0C	ALS_THRES_LL	R/W	0x00	ALS low interrupt threshold - LSB
0x0D	ALS_THRES_LH	R/W	0x00	ALS low interrupt threshold - MSB
0x0E	ALS_THRES_HL	R/W	0xFF	ALS high interrupt threshold - LSB
0x0F	ALS_THRES_HH	R/W	0xFF	ALS high interrupt threshold - MSB
0x17	DATA_STATUS	R/W	0x00	Data status
0x1E	ALS_DATA_L	R	0x00	ALS channel output data - LSB
0x1F	ALS_DATA_H	R	0x00	ALS channel output data - MSB
0xBC	PROD_ID_L	R	0x11	Product ID - LSB
0xBD	PROD_ID_H	R	0x10	Product ID - MSB

### 0x00 SYSM\_CTRL

0x00	SYSM_CTRL, System Control (Default = 0x00)							
BIT	7	6	5	4	3	2	1	0
R/W	SWRST	EN_WAIT	EN_FRST	0	0	0	EN_ONCE	EN_ALS

**SWRST:** Software reset. Reset all register to default value.

0: (Default)

1: Reset will be triggered.

**EN WAIT:** Waiting time will be inserted between two measurements.

0: Disable waiting function. (Default)

1: Enable waiting function.

**EN FRST:**

0: Enable (Brown out Reset circuit enable). (Default)

1: Disable (Brown out Reset circuit disable).

**EN ONCE =** Enables ALS function once.

0: Disable ALS function. (Default)

1: Enable ALS function.

**EN ALS:** Enables ALS function.

0: Disable ALS function. (Default)

1: Enable ALS function

### 0x01 INT\_CTRL

0x01	Interrupt Pin Control (Default = 0x01)							
BIT	7	6	5	4	3	2	1	0
R/W	0	0	0	ALS_SYNC	0	0	0	EN_AINT

**ALS SYNC =** Measurement is pended when ALS interrupt is triggered. Until clear the interrupt then start the next measurement.

0: Disable pending ALS function.(Default)

1: Enable pending ALS function.

**EN AINT =** The ALS interrupt (INT\_ALS) flag can trigger the INT pin to low.

0: Disable INT\_ALS effect INT pin.

1: Enable INT\_ALS effect INT pin. (Default)

## 0x02 INT\_FLAG

0x02	INT_FLAG, System Control (Default = 0x00)							
BIT	7	6	5	4	3	2	1	0
R/W	INT_ POR	DATA_ FLAG	0	0	0	0	0	INT_ALS

**INT POR:** Power-On-Reset Interrupt flag trigger the INT pin when the flag sets to one. Write zero to clear the flag.

0:

1: This bit will be set to one when it satisfy one of the following conditions:

- Power On
- VDD < 1.4V
- SWRST

**DATA FLAG =** It shows if any data is invalid after completion of each conversion cycle. This bit is read-only.

0: Data valid.

1: Data invalid.

**INT ALS =** ALS Interrupt flag. It correlation with CH0/1 data and ALS high/low threshold. Write zero to clear the flag.

0: ALS interrupt not triggered or be cleared.

1: ALS interrupt triggered

## Interrupt Behavior

The interrupt pin will be pulled low when POR occur or ALS interrupt trigger.

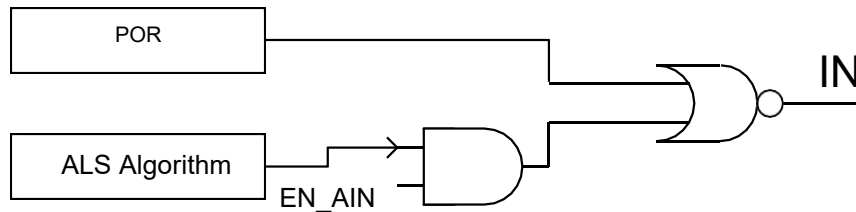

## ALS Interrupt Algorithm

Correlative register:

The ALS Interrupt (**INT ALS, register 0x02, bit0**).

The ALS Persistence (**PRS ALS, register 0x0B, bit0 to bit3**),

The ALS Data (**ALS channel data, register 0x1E to 0x1F**),

The ALS Low Threshold (**ALS THRES L, register 0x0C to 0x0D**),

The ALS High Threshold (**ALS THRES H, register 0x0E to 0x0F**)

**INT ALS** triggered condition:

1. Rule of active interrupt: **DATA > ALS THRES H** or **DATA < ALS THRES L**.
2. If the **DATA** meets the rule, the **interrupt** count increases one.  
If the **DATA** fails in the rule, the interrupt count will be clear.
3. When the **interrupt** count equal to **PRS ALS setting, INT ALS** will be triggered and reset the interrupt counter.
4. If **PRS ALS** is set to zero, **threshold** will be ignored and **DATA** will meets the active interrupt rule forcibly.

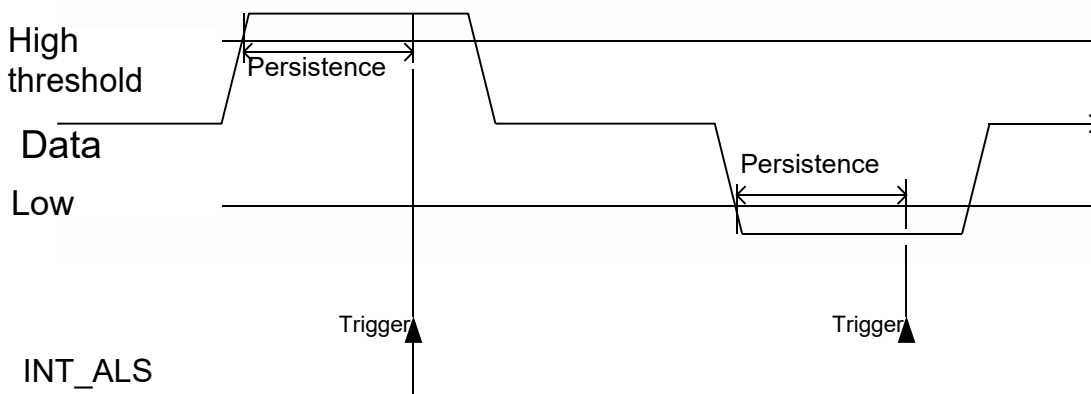

**0x03 WAIT\_TIME**

0x03	WAIT_TIME, waiting time (Default = 0x00)							
BIT	7	6	5	4	3	2	1	0
R/W	WTIME_UNIT			WTIME				

**WTIME\_UNIT =** \_\_\_\_ This register controls the waiting time unit of waiting state which is inserted between any two measurements. It is 8 ms per time unit.

- 0x0: 1 time unit. (Default)
- 0x1: 2 time units.
- 0x2: 4 time units.
- 0x3: 8 time units.

**WTIME\_STEP =** \_\_\_\_ This register controls the time step of waiting state. It is increase one WTIME\_UNIT per step.

- 0x00: 1 WTIME\_UNIT. (Default)
- 0x01: 2 WTIME\_UNIT.
- .....
- 0x3f: 64 WTIME\_UNIT.

Total waiting time = **WTIME\_STEP x WTIME\_UNIT**

**0x04 ALS\_GAIN**

0x04	ALS_GAIN, ALS analog gain (Default = 0x01)							
BIT	7	6	5	4	3	2	1	0
R/W	PD_SEL	0	0	PGA_ALS				

**PD\_SEL =** \_\_\_\_ PD gain select.

- 0x00: x1 (Default)
- 0x01: x2

**PGA\_ALS =** \_\_\_\_ ALS sensing gain.

- 0x01: x1 (Default)
- 0x02: x4
- 0x04: x16
- 0x08: x64
- 0x10: x256

**0x05 ALS\_TIME**

0x05	ALS_TIME, ALS integrated time (Default = 0x03)							
BIT	7	6	5	4	3	2	1	0
R/W	ALSCONV				0	0	INT_TIME	

**ALSCONV:** This register controls the conversion time of AD converter at ALS mode ( $T_{ALS}$ ), and the resolution of output dat.

0x0:  $T_{ALS} = 1 * INT\_TIME$  (Default)

0x1:  $T_{ALS} = 2 * INT\_TIME$

.....

0xf:  $T_{ALS} = 16 * INT\_TIME$

**INT TIME:** This register controls the integrated time.

0x0:  $INT\_TIME (T) = 1.171 \text{ ms}$ , the maximum count of **output data is** 1023.

0x1:  $INT\_TIME (4T) = 4.683 \text{ ms}$ , the maximum count of **output data is** 4095.

0x2:  $INT\_TIME (16T) = 18.731 \text{ ms}$ , the maximum count of **output data is** 16383.

0x3:  $INT\_TIME (64T) = 74.923 \text{ ms}$ , the maximum count of **output data is** 65535. (Default)

The conversion time of ALS function ( $T_{ALS}$ ) is decided by **ALSCONV and INT TIME.**

$$T_{ALS} = INT\_TIME \times (ALSCONV + 1) \quad (\text{ms})$$

EX:

Setting  $INT\_TIME = 0x01$  (4T UNIT) and  $ALSCONV = 0x01$

The maximum count of **output data is** minimum of

$$[1024 \times [INT\_TIME * (ALSCONV + 1)] - 1, 65535]$$

$$= [1024 \times [4 * (1 + 1)] - 1, 65535].$$

**0x0B PERSISTENCE**

0x0B	PERSISTENCE, ALS persistence setting (Default = 0x01)							
BIT	7	6	5	4	3	2	1	0
R/W	0			INT_ SRC	PRS_ALS			

**INT SRC =** This register sets to select the ALS data for the ALS Interrupt algorithm.

0x00: Select ALS\_DATA. (Default)

0x01: Select COMP\_DATA.

**PRS ALS:** This register sets the numbers of similar consecutive ALS interrupt events before the interrupt pin is triggered.

- 0x0: Every ALS conversion is done.
- 0x1: 1 ALS interrupt event is asserted. (Default)
- .....
- 0xf: 15 consecutive ALS interrupt events are asserted.

**0x0C/0x0D ALS\_THRES\_L**

0x0C 0x0D	ALS_THRES_L, ALS low interrupt threshold (Default = 0x0000)							
BIT	7	6	5	4	3	2	1	0
R/W	ALS_THRE_LL							
R/W	ALS_THRE_LH							

This register sets the lower threshold value of ALS interrupt. The interrupt algorithm compares the selected ALS data and ALS threshold value.

**ALS THRE LL:** ALS lower interrupt threshold value, LSB. (Reg. 0x0C)

**ALS THRE LH:** ALS lower interrupt threshold value, MSB. (Reg. 0x0D)

**0x0E/0x0F ALS\_THRES\_H**

0x0E 0x0F	ALS_THRES_H, ALS high interrupt threshold (Default = 0xFFFF)							
BIT	7	6	5	4	3	2	1	0
R/W	ALS_THRE_HL							
R/W	ALS_THRE_HH							

This register sets the high threshold value of ALS interrupt. The interrupt algorithm compares the selected ALS data and ALS threshold value.

**ALS THRE HL:** ALS high interrupt threshold value, LSB. (Reg. 0x0E)

**ALS THRE HH:** ALS high interrupt threshold value, MSB. (Reg. 0x0F)

### 0x17 DATA\_STATUS

0x17	DATA_STAT_0, Data status							
BIT	7	6	5	4	3	2	1	0
R	DATA_ REDY	0	0	0	0	0	SAT_ ALS	SAT_ COMP

This register indicates the ALS data status.

The data ready flag will set to one when the data register is updated. After read the data register, the data ready flag will clear to zero.

If the ALS data is outside of measurable range, the corresponding saturation flag will set to one. That means the data is invalid.

### 0x1E/0x1F ALS\_DATA

0x1E 0x1F	ALS_DATA, ALS channel output data.							
BIT	7	6	5	4	3	2	1	0
R	ALS_DATA_L							
R	ALS_DATA_H							

The result of ALS sensor is written into ALS\_DATA when ALS conversion is done.

For insuring the data in the register comes the same measurement, the high byte data will be latched when the low byte data has being accessed until the high byte data has be read..

## I<sup>2</sup>C Interface Timing Characteristics

This section will describe the protocol of the I<sup>2</sup>C bus. For more details and timing diagrams please refer to the I<sup>2</sup>C specification.

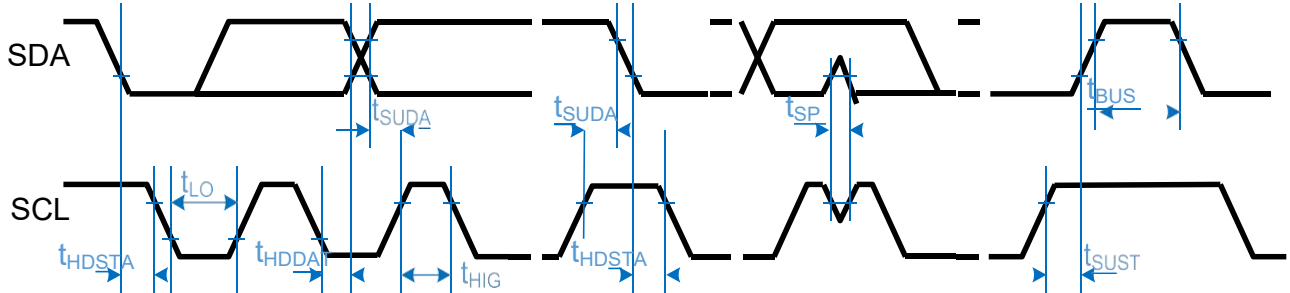

Parameter (*)	Symbol	Fast mode		Unit
		Min	Max	
SCL clock frequency	$f_{SCL}$	100	400	kHz
Bus free time between STOP condition and START condition	$t_{BUS}$	1.3	--	$\mu s$
LOW period of the SCL clock	$t_{LOW}$	1.3	--	$\mu s$
HIGH period of the SCL clock	$t_{HIGH}$	0.6	--	$\mu s$
Hold time (repeated) START condition	$t_{HDSTA}$	0.6	--	$\mu s$
Set-up time (repeated) START condition	$t_{SUSTA}$	0.6	--	$\mu s$
Set-up time for STOP condition	$t_{SUSTO}$	0.6	--	$\mu s$
Data hold time	$t_{HDDAT}$	50	--	ns
Data set-up time	$t_{SUDAT}$	100	--	ns
Pulse width of spikes which must be suppressed by the input filter	$t_{SP}$	0	50	ns
Rise time of both SDA and SCL signals		20 x VDD/5.5	300	ns
Fall time of both SDA and SCL signals		20 x VDD/5.5	300	ns

(\*) Specified by design and characterization; not production tested.

(\*\*) All specifications are at  $V_{BUS} = 3.3V$ ,  $T_{ope}=25^{\circ}C$ , unless otherwise noted.

**Note:**

**I<sup>2</sup>C Bus Clear**

In the unlikely event where the clock (SCL) is stuck LOW, the preferential procedure is to reset the bus using the HW reset signal if your I2C devices have HW reset inputs. If the I2C devices do not have HW reset inputs, cycle power to the devices to activate the mandatory Internal Power-On Reset (POR) circuit.

If the data line (SDA) is stuck LOW, the master should send nine clock pulses. The device that held the bus LOW should release it sometime within those nine clocks.

**I<sup>2</sup>C General Call Software Reset**

Following a General Call, (0000 0000), sending 0000 0110 (06h) as the second byte causes software reset. This feature is optional and not all devices will respond to this command. On receiving this 2-byte sequence, all devices designed to respond to the general call address will reset and take in the programmable part of their address.

Precautions have to be taken to ensure that a device is not pulling down the SDA or SCL line after applying the supply voltage, since these low levels would block the bus.

**Application Circuit**

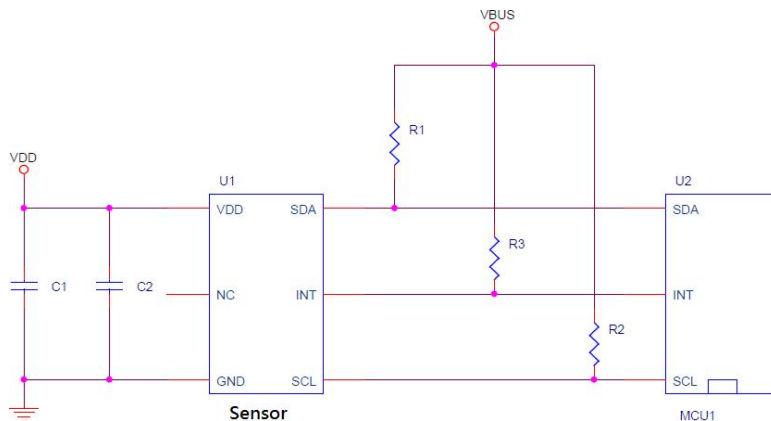

The capacitors (C1, C2) are required for power supply. The capacitors should be placed as close as possible to the device. The high frequency AC noises can be shunted to the ground by the capacitors. The transient current caused by digital circuit switching also can be handled by the capacitors. A typical value 0.1 / 1  $\mu$ F can be used.

The pull-up resistors (R1, R2) are required for I<sup>2</sup>C communication. At fast speed mode (400kHz/s) and VBUS = 3.3V, 2.2k $\Omega$  resistors can be used. The pull-up resistor (R3) is also required for the interrupt, a typical value between 10 k $\Omega$  and 100 k $\Omega$  can be used.

**Package Outline Dimensions**

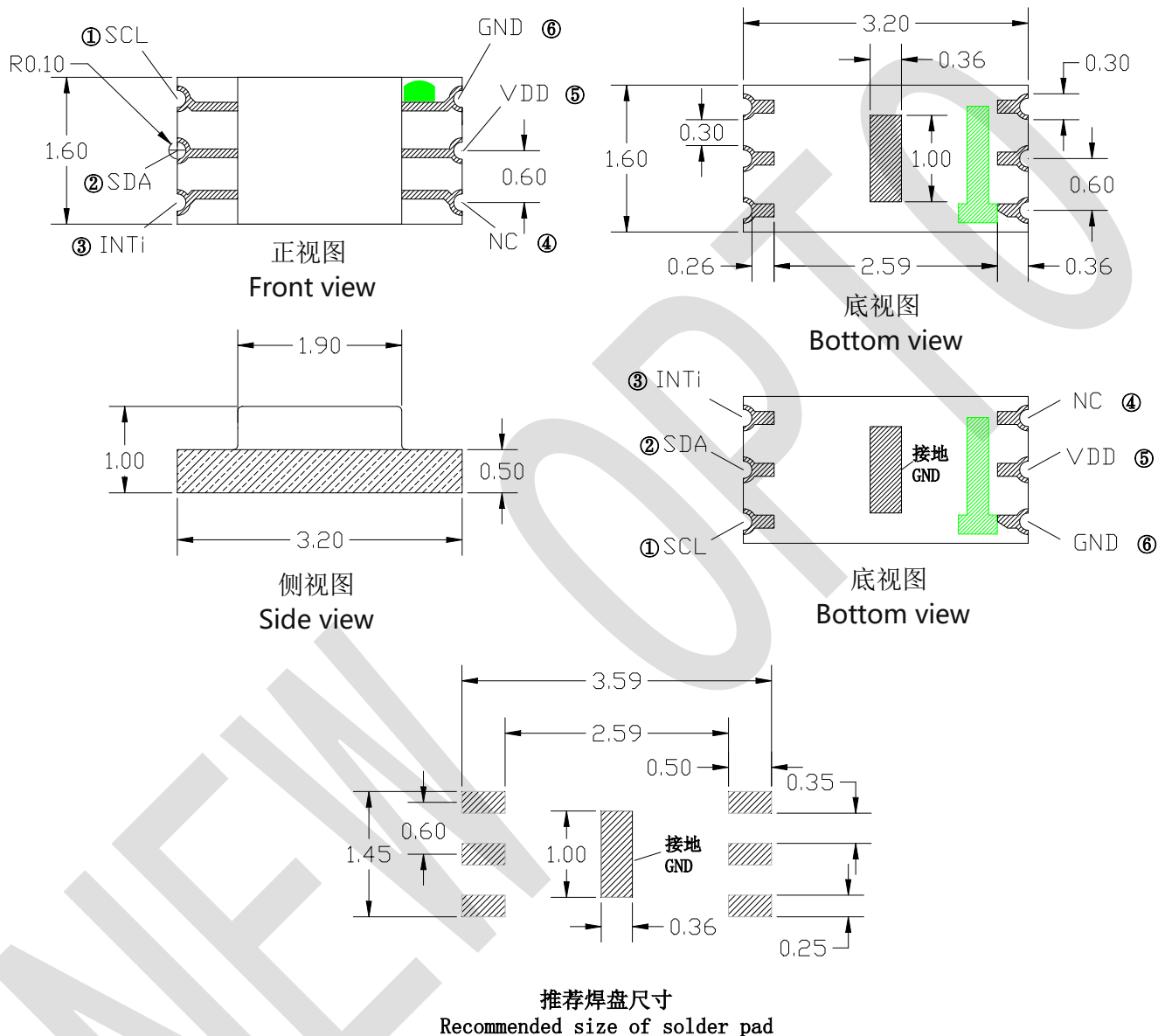

Note: All dimensions in mm, tolerance is  $\pm 0.15\text{mm}$  unless otherwise noted

**Packing Specification**

■ Carrier Tape

编带3000pcs/卷 Quantity 3000 pcs Per Reel

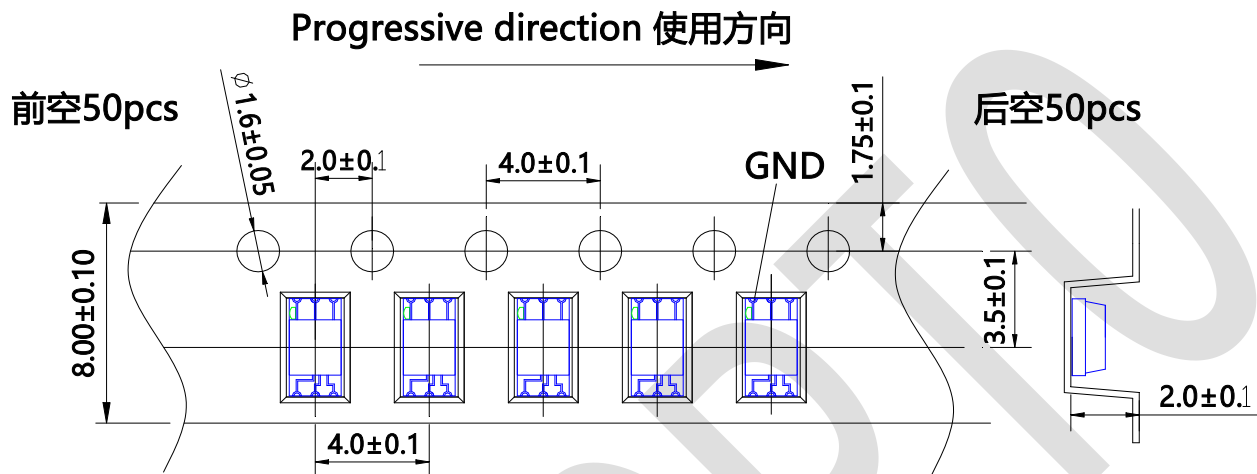

■ Reel Dimensions

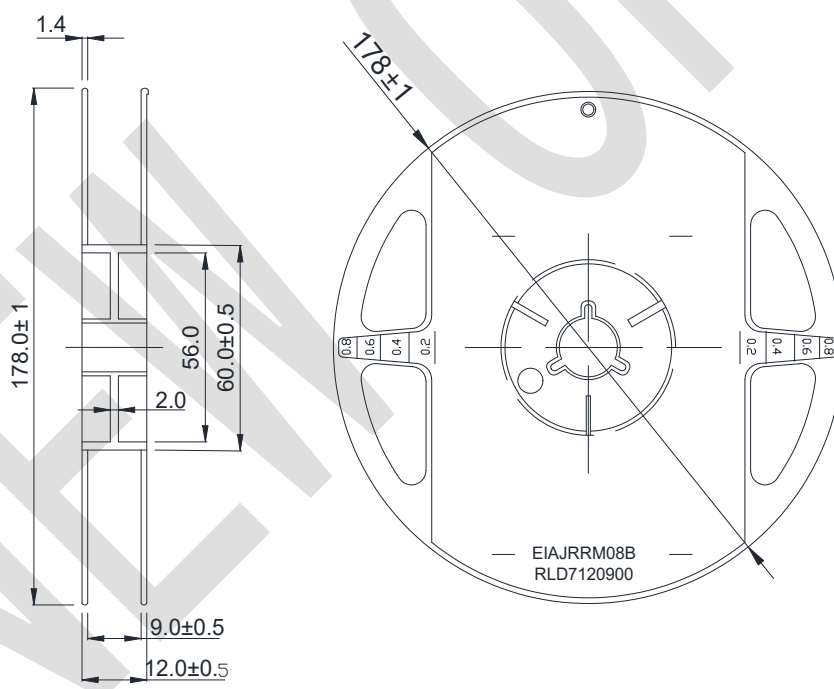

Note: Tolerance s unless mentioned  $\pm 0.01$ mm. Unit=mm

■ Moisture Resistant Packing Process

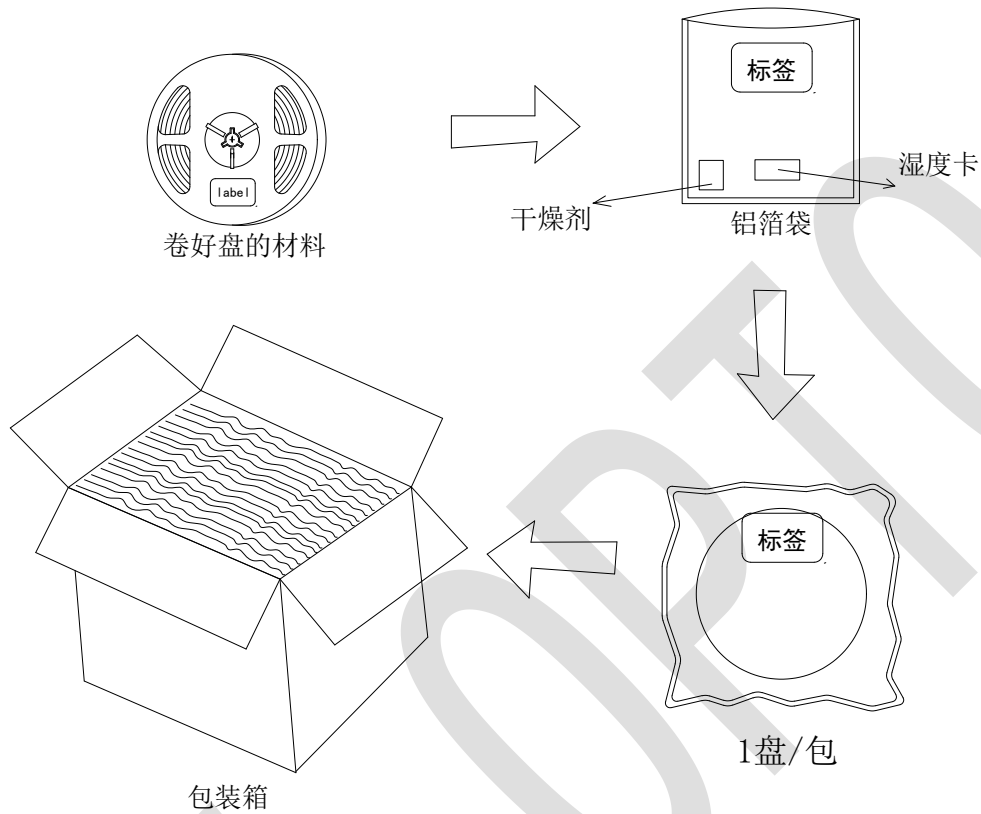

## 回流焊Reflow

- 回流焊接：推荐使用以下回流焊接温度图进行

Reflow Soldering: Use the conditions shown in the under Figure o Reflow Soldering.

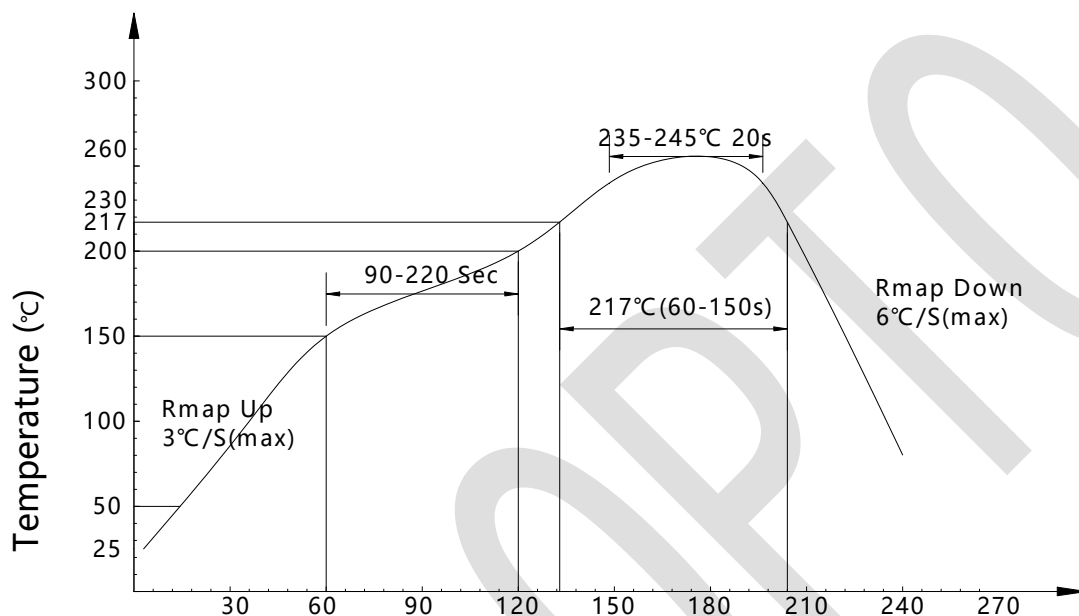

### ■ 回流焊接Reflow Soldering

- 回流焊次数不可以超过一次，否则ALS 可能损坏。

Reflow soldering should not be done more than once, or ALS will be damaged.

- 当焊接时，不要在材料受热时用力压胶体表面。

When soldering, do not put stress on the ALS during heating.

- 建议回流链速：80-100cm/min（回流炉以8温区为基准，温区越多建议使用链速更快）

Please be sure the speed of the chain is 80-100cm/min (The reflow furnace is based on 8 temperature zone, the more temperature zone, the faster speed of the chain is recommended.)

### ■ 烙铁焊接Soldering iron

- 如使用手工焊接，建议使用小于25瓦的电烙铁，烙铁温度必须空置在300°C以下，焊接时间需控制在3秒钟以内，且每个点击只能焊接一次。

If solder manually, it is recommended to use soldering iron less than 25W. The temperature of the iron must be kept below 300°C. And soldering time should be within 3 seconds, each point can only be soldered once only.

- 当焊接时，不要在材料受热时用力压胶体表面。

When soldering, do not put stress on the LED colloid surface during heating.

- 手工焊接只可焊接一次。

- Manually soldering should be done once only

- 器件外部温度在40°C以下时，才可以对其进行处理。避免高温时操作对LED造成损伤。

Handling of the SMD LED should be done when the package has been cooled down to below 40°C or less. This is to prevent LED failures due to thermal-mechanical stress during handling.

#### ■ 清洗Cleaning

- 在焊接后推荐使用酒精进行清洗，在温度不高于30°C的条件下持续3分钟，不高于50°C的条件下持续30秒。使用其他类似溶剂清洗前，请先确认使用的溶剂不会对LED的封装和陶瓷底座部分造成损伤。

It is recommended that alcohol be used as the solvent for cleaning after soldering. Cleaning should be done under 30°C for 3 minutes or 50°C for 30 seconds. When using other solvents, it should be confirmed beforehand whether the solvents will dissolve the package and the resin or not.

#### ■ 修补Repairing

- LED回流焊后不应该修复，当修复是不可避免时，必须使用双头烙铁，但必须事先确认此种方式会或不会损坏LED本身的特性。

Repair should not be done after the LEDs have been soldered. When repairing is unavoidable, a double-head soldering iron should be used (as below figure). It should be confirmed in advance the characteristics of LEDs will not be damaged by repairing.

注意：此一般指导原则并不适用于所有PCB设计和焊接设备的配置。具体工艺收到诸多因素的影响，请根据特定的PCB设计和焊接设备来确定焊接方案。

Note: This general guideline may not suitable for all PCB designs or configurations of all soldering equipment. The technique in practice is influenced by many factors, it should be specialized base on the PCB designs and configurations of the soldering equipment.

## 使用注意事项Precautions

感谢您使用惠州市鑫永诚光电科技有限公司的系列LED产品，为增进您对我公司产品特性的了解，也为方便您快速掌握产品的基本操作，为尽量减少或避免因人为等因素造成不必要的产品损坏，使其能够更好的为您的生产服务，特针对使用过程中的一些规范使用作相应说明，同时即使是同一规格LED，在实际应用领域其可靠性与整体系统设计水平、作业方式、使用条件均相关。本使用说明不可能涵盖客户使用过程中可能碰到的所有问题，由此带来的不便，敬请谅解！

Thanks for using relevant LED products of Huizhou Newpoto Optoelectronic Technology Co., Ltd. in order to enhance your understanding of the characteristics of our products, as far as possible to reduce or avoid unnecessary damage to the product due to human factors, and make it can better service your production. We give corresponding instructions, According to the characteristic in the process of standard use. At the same time, even if the same specifications LED, in the practical application field its reliability are related to overall system design level, mode of operation and conditions of use. This Instructions can't cover all questions may encounter during customer use process, We sincerely apologize for any inconvenience this may cause!

### ■ 产品声明

- 使用本产品之前，请贵司务必预先进行测试，以便确认是否适合使用目的，产品介绍的用途并不保证不抵触任何专利，有关LED产品的进出口法律责任应由客户担负，请预先查清每个国家或地区的有关规定。产品可能会因性能提升而更改物料和规格参数，恕不另行通知。

In order to confirm the product is right for using purpose , pretest is necessary before use . We don' t guarantee the product application introduction don' t contravene any patent. The corresponding import and export legal responsibility should be taken by customers. Please verify relevant provision about the LED product in each country and district beforehand. We may change material and specifications from time to time in the interest of product development, without prior notification or public announcement.

### ■ 储存Storage

- 本产品使用密封防潮防静电袋包装,并附有干燥剂,未开封的产品保存时间2个月。

The products are stored in sealed anti-moisture and anti-static package with moisture absorbent. Unopened package can be stored 2 months.

- 开封前,产品须存放在温度不高于30°C,湿度不高于60%RH的环境中。

Before opening the package, the product should be kept at 30°C or less and humidity less than 60%RH.

- 密封防静电袋内的湿度卡应在打开袋子后立即查看袋内的湿度指示卡来确定,湿度显示小于或等于30%时,使用前须进行烘烤。

Humidity of sealed anti-static bag is subject to the humidity value shows in humidity card at the moment opening the bag. If humidity shows equal or less than 30%, the products should be baked before use.

- 开封后,产品必须24小时内使用完(建议工作环境温度不高于30°C,湿度不高于60%),如未使用完,余料须存放在温度不高于30°C,湿度不高于10%的环境中。

After opening the package, the product should be soldered within 24 hours. If not, please store at 30°C or less and humidity less than 10%RH. It is recommended that the product be operated at the workshop condition of 30°C or less and humidity less than 60%RH.

- 对于尚未焊接的LED,如果吸湿剂或包装失效,或者产品没有符合以上有效存储条件,烘烤可以起到一定的性能恢复效果. 烘烤条件:65±5°C,持续时间24H。

For the LED doesn't solder ,if the moisture absorbent material lose efficacy or the storage condition doesn't conform to the above description, baking can help some extent performance recovery .Backing condition :  $65\pm 5^{\circ}\text{C}$  for 24 hours.

#### ■ 静电Static Electricity

以下操作可降低静电破坏的可能性。

The following operations may decrease the possibility of ESD damage.

- 将产品和外界之间的摩擦减到最低以避免静电产生。

Minimize friction between the product and surroundings to avoid static.

- 所有的产品设备和测试仪器必须接地。

All production machinery and test instruments must be grounded.

- 操作人员必须配戴静电环。

Operators must wear anti-static bracelets.

- 进入带电设备工作区域时需穿防静电服。

Wearing anti-static garment when entering into electric devices working areas.

- 所有操作 IC 和 ESD 敏感器件元器件的工作台必须保持低于 150V 的静电保护。

All workstations that operate IC and ESD-sensitive components must maintain an electrostatic protection of 150V or less.

#### ■ 温度保护The safe temperature for LEDs working

- LED 在高温条件下, 衰减会加速, 本身应力也会增大, 若长期处于高温环境下, 极容易出现失效. 对于高密度排列使用的情况, 建议在使用过程中灯面温度不超过  $55^{\circ}\text{C}$ , 灯脚温度不超过  $75^{\circ}\text{C}$ .

The high temperature will make the LED's luminous intensity decreased radically. If LED worked in high temperature environment for a long time, it would lose efficacy easily. When LEDs are working in a closed array, it is suggested that the LED's surface temperature be lower than  $55^{\circ}\text{C}$  and the pin's temperature be lower than  $75^{\circ}\text{C}$ .

#### ■ 其他事项Others

- 请勿直接触摸或操作透镜表面, 这可能会损坏内部的电路, 拿取时用镊子或合适的工具夹在元件的侧边。

Do not touch or operate the lens surface directly, it may damage the internal circuitry. Handle the component along the side surfaces by using tweezers or appropriate tools.

- LED的底座部分相当脆弱, 请勿用坚硬、尖锐的物体刮、擦封装树脂部分。在用镊子夹取的时候也应当小心注意。

The base of LED is fragile, so please avoid scratch or friction over the epoxy resin surface. While handing the product with tweezers, do not hold by the epoxy resin, be careful.

