

REVISION RECORD				
REV	ECD	DESCRIPTION	DRFT	CHKD

NOTES:

MATERIAL:

1. HOUSING MATERIAL : GLASS FILLED POLYESTER UL94V-0.
2. CONTACT MATERIAL : PHOSPHOR BRONZE $\varnothing=0.46\text{mm}$.
3. PLATING : GOLD PLATING $3\mu\sim 50\mu$ OVER NICKEL

ELECTRICAL:

1. VOLTAGE RATING : 125 VAC RMS.
2. CURRENT RATING : 1.5 AMP.
3. CONTACT RESISTANCE : 30 MILLIOHMS MAX.
4. INSULATION RESISTANCE : 500 MEGOHMS MIN @ 500V DC .
5. DIELECTRIC WITHSTANDING RESISTANCE : 1000V AC RMS 50Hz. 1MIN.

MECHANICAL:

1. DURRABILITY: : 750 CYCLES MIN.
2. PCB RETENTION PRE-SOLDER : 1 LB MIN.

ENVIRONMENTAL:

1. STORAGE : -40°C TO 85°C .
2. OPERATION : 0°C TO 70°C .

PART NUMBER:

52A SERIES JACK ZP52A 8 X - X X X X X X

POSITIONS 4-4 POSITIONS 6-6 POSITIONS 8-8 POSITIONS 1-10 POSITIONS	CONTACTS 2-2 CONTACTS 4-4 CONTACTS 6-6 CONTACTS 8-8 CONTACTS 1-10 CONTACTS	PEG 1-SPLIT LONG PEG 2-SPLIT SHORT PEG 3-'L' PEG	PANEL 0-W/O PANEL 1-W/ PANEL	PLASTIC 1-PBT 2-NYLDN66 3-NYLDN46 4-ABS	COLOR 1-BLACK 2-WHITE 3-GRAY 4-IVDRY	LOGO 0-W/O LOGO 1-W/ ZPY 2-W/ UL 3-W/ ZPY&UL	GOLD PLATING 1-15 μ ' 2-3 μ ' 3-6 μ ' 4-15 μ ' 5-30 μ ' 6-50 μ '
--	---	---	------------------------------------	---	--	--	--

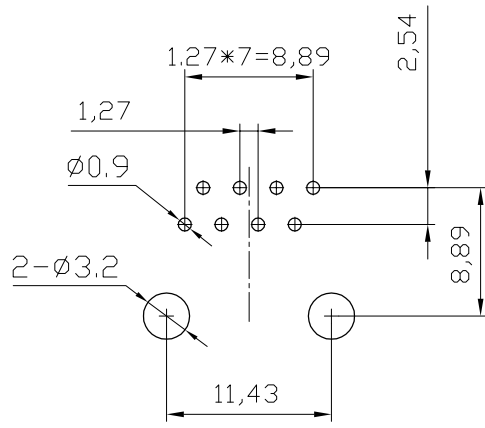
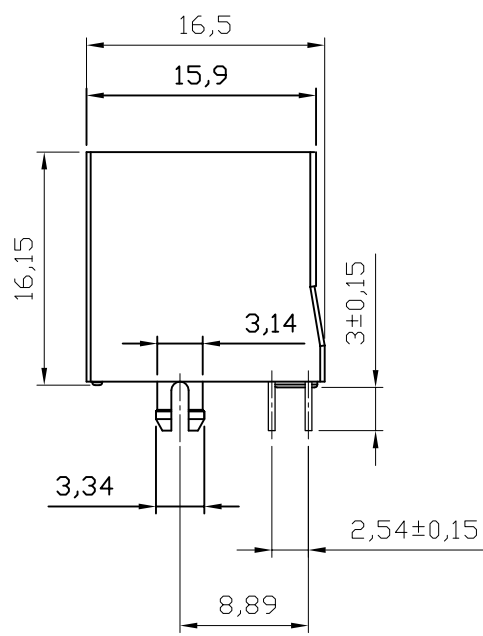
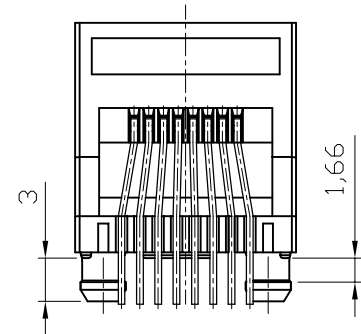
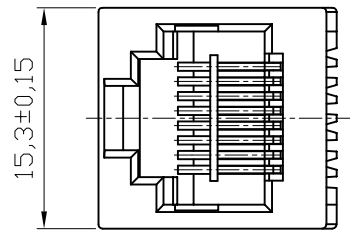

PC Board Layout
Component Side Shown

DETACHED LISTS	MM (INCH)	DFTD: SHB	DATE: 2007.05.05	连兴旺电子(深圳)有限公司 LXWCONN ELECTRONICS (SHENZHEN) CO., LTD
	TOLERANCES EXCEPT AS NOTED	CHKD: LANBD	DATE: 2007.05.05	
	MM	MFO:	DATE:	
	.0 ± 0.15 ± .00 ± 0.075 ± .000 ± 0.05 ±	APPLV:	DATE:	
ANGLES ± 0.5	QTY :	MATERIAL :	TITLE	52A-1*1-8P8C DRAWING NO. TE52A1001 /PART NO. 52A-1X1-8P8C DO NOT SCALE DRAWING
THIRD ANGLE PROJECTION	FINISH :	SCALE :	SIZE REV A3 0	
			SHEET X OF Y	