

GENERAL DESCRIPTION

The LW64XX series is a group of 40V high accuracy LDO. The 2.5 μ A power consumption makes it ideal for most HV power-saving systems. The maximum operating voltage can be as high as 40V. The LW64XX can deliver 150mA output current.

The other features include current limiting protection, short circuit protection and thermal shutdown protection.

Output voltage is selectable from 2.5V to 5.0V which fixed by laser trimming technologies, Step=100mV.

The LW64XX is available in SOT23-3L, DFN2x2-6L and SOT89-3L packages.

FEATURES

- Low Power Consumption: 2.5 μ A(Typ.)
- Operating Voltage Range: from 3.5V to 40V
- Output Voltage Range: from 2.5V to 5.0V
- Maximum Output Current: 150mA
- Output Accuracy: $\pm 1.0\%$
- Low Dropout Voltage: 810mV@150mA/3.3V
- High PSRR: 85dB@1KHz, 10mA
- Current Limiting Protection
- Output Short-Circuit Protection
- Over-Temperature Protection
- Stable with 1 μ F Output Capacitor

APPLICATIONS

- Battery Supplied Systems
- Telecom Systems
- Portable Audio & Video Equipment

TYPICAL APPLICATION CIRCUIT

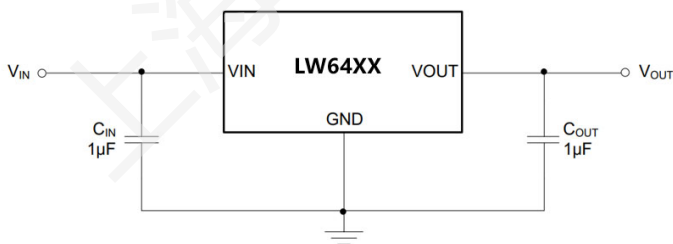

TYPICAL PERFORMANCE CHARACTERISTICS

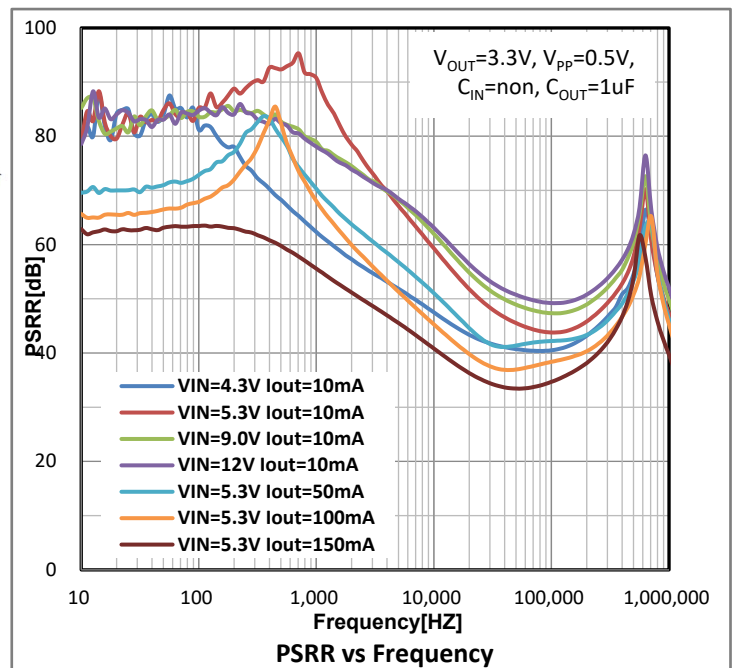

PIN DESCRIPTION:

PIN No				SYMBOL	DESCRIPTION
SOT23-3L	DFN2x2-6L	SOT89-3L (Type-A)	SOT89-3L (Type-B)		
3	1	2、TAB	3	VIN	Input pin. Use the recommended capacitor value as listed in the Recommended Operating Conditions table. Place the input capacitor as close to the IN and GND pins of the device as possible.
1	3	1	2、TAB	GND	Ground pin. All ground pins must be grounded.
2	6	3	1	VOUT	Output pin. Use the recommended capacitor value as listed in the Recommended Operating Conditions table. Place the output capacitor as close to the OUT and GND pins of the device as possible.
--	Thermal pad	--	--	Pad	The thermal pad is electrically connected to the GND node. Connect to the GND plane for improved thermal performance.

PIN ASSIGNMENT

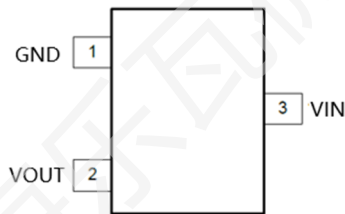

SOT23-3L

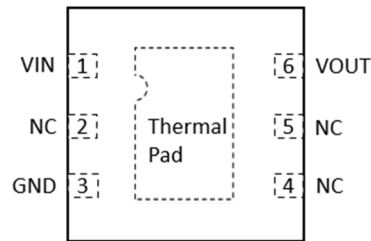

DFN2x2-6L

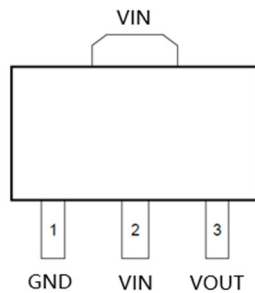

SOT89-3L(Type-A)

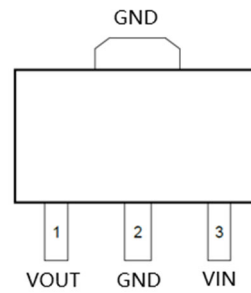

SOT89-3L(Type-B)

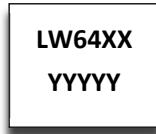
MARK INFORMATION:**SOT23-3L/SOT89-3L****XX: VOLTAGE****Y: DATE CODE**

LW64XX
YYYYY

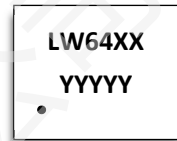
DFN2x2-6L**XX: VOLTAGE****YY: DATE CODE**

LW64XX
YYYYY

ABSOLUTE MAXIMUM RATINGS ⁽¹⁾:

Symbol	Item	Rating	Unit	
V_{IN}	Supply Voltage	-0.3~44	V	
V_{OUT}	V_{OUT} pin to GND Voltage	-0.3~5.0	V	
$V_{(ESD)}$	ESD Susceptibility, Human-body model ⁽²⁾	±2000	V	
$R_{\theta JA}$	Junction-to-ambient Thermal Resistance ⁽³⁾	SOT23-3L	350	°C/W
		DFN2x2-6L	90	°C/W
		SOT89-3L(Type-A)	125	°C/W
		SOT89-3L(Type-B)	100	°C/W
T_J	Junction Temperature Range	-40~150	°C	
T_{STG}	Storage Temperature Range	-40~150	°C	
T_{SOLDER}	Lead Temperature (Soldering)	260°C, 10s		

Note:

1. Absolute Maximum Ratings are threshold limit values that must not be exceeded even for an instant under any condition. Moreover, such values for any two items must not be reached simultaneously. Operation above these absolute maximum ratings may cause degradation or permanent damage to the device. These are stress ratings only and do not necessarily imply functional operation below these limits.

2. per ANSI/ESDA/JEDEC JS-001

3. Device mounted on FR-4 PCB, Refer to JESD51-3 for detailed information on the board construction

RECOMMENDED OPERATING RANGE:

Symbol	Item	Rating	Unit
V_{IN}	V_{IN} Supply Voltage	3.5~40	V
V_{OUT}	V_{OUT} Pin Voltage	2.5~5.0	V
I_{OUT}	Output Current	0~150	mA
T_J	Junction Temperature Range	-40~125	°C

ELECTRICAL CHARACTERISTICS:

($V_{IN}=V_{OUT}+1V$ or $2V$, whichever is greater, $C_{IN}=C_{OUT}=1\mu F$, unless otherwise specified, Typical values are at $T_A=25^{\circ}C$.)

Symbol	Parameter	Test Conditions	MIN	TYP	MAX	Units
V_{IN}	Input Voltage		3.5		40	V
V_{OUT}	Output Accuracy	$I_{OUT}=1mA$	-1.0		+1.0	%
I_{LIM}	Current Limit ⁽¹⁾		150	230		mA
I_Q	Quiescent Current	$V_{IN}=V_{OUT}+1V$, No Load		2.5	5.0	μA
V_{DROP}	Dropout Voltage ⁽¹⁾⁽²⁾	$I_{OUT}=50mA, V_{OUT}=2.5V$		325		mV
		$I_{OUT}=100mA, V_{OUT}=2.5V$		655		
		$I_{OUT}=150mA, V_{OUT}=2.5V$		985		
		$I_{OUT}=50mA, V_{OUT}=3.3V$		260		
		$I_{OUT}=100mA, V_{OUT}=3.3V$		530		
		$I_{OUT}=150mA, V_{OUT}=3.3V$		815		
		$I_{OUT}=50mA, V_{OUT}=5.0V$		245		
		$I_{OUT}=100mA, V_{OUT}=5.0V$		500		
$\Delta V_{OUT}/(\Delta V_{IN} * V_{OUT(NOM)})$	Line Regulation	$V_{IN}=V_{OUT(NOM)}+1V$ to $40V$, $I_{OUT}=1mA$		0.01	0.02	%/V
ΔV_{OUT}	Load Regulation	$V_{IN}=V_{OUT(NOM)}+1V$, $1mA \leq I_{OUT} \leq 150mA$		20	40	mV
I_{SHORT}	Short Current ⁽¹⁾	$V_{OUT}=0V$		80		mA
PSRR	Power Supply Rejection Ratio	$V_{IN}=5.3V, V_{PP}=0.5V$ $C_{IN}=None, V_{OUT}=3.3V$ $I_{OUT}=10mA$	$f=217Hz$	80		dB
			$f=1KHz$	85		
			$f=10KHz$	60		
e_n	Output Voltage Noise	$f=10Hz$ to $100kHz$, $V_{IN}=4.3V, V_{OUT}=3.3V$	$I_{OUT}=0mA$	92		μV_{RMS}
			$I_{OUT}=10mA$	125		
T_{SD}	Overheat Protection	Temperature rising		155		$^{\circ}C$
ΔT_{SD}	TSD Hysteresis	Temperature falling		30		$^{\circ}C$

NOTES:

1. Guaranteed by design
2. The dropout voltage is defined as $V_{IN} - V_{OUT}$, when $V_{OUT}=95% * V_{OUT(NOM)}$

SIMPLIFIED BLOCK DIAGRAM:

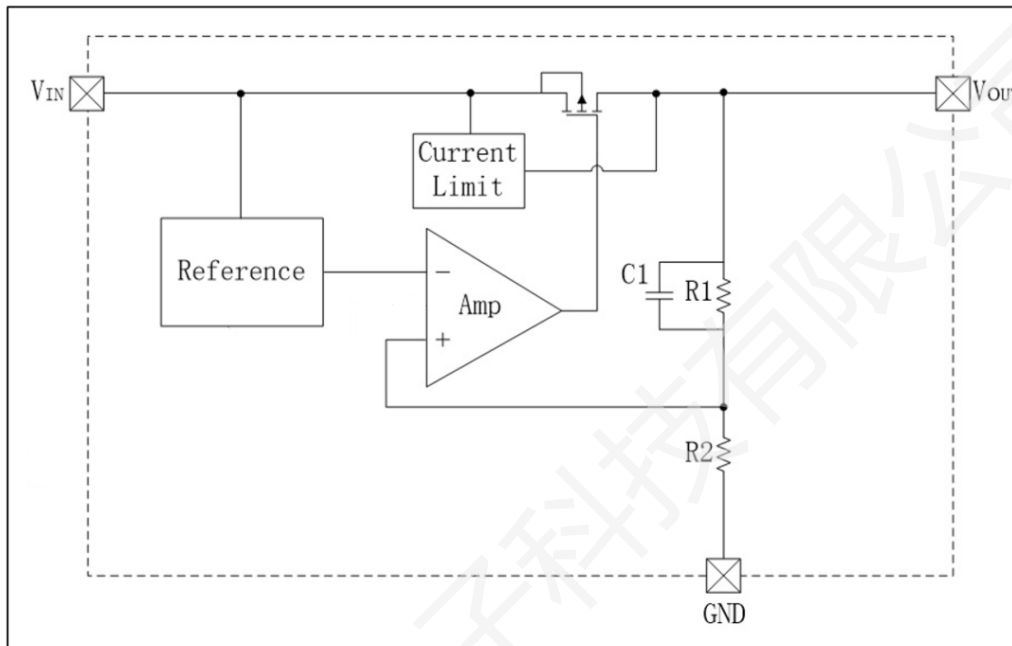

DETAIL OPERATION DESCRIPTION:

The LW64XX Series is a low power consumption low drop-out voltage regulator. It consists of a current limiter circuit, a driver transistor, a precision reference voltage and an error correction circuit, and is compatible with low ESR ceramic capacitors. The current limiter's fold-back circuit operates as a short circuit protection as well as the output current limiter.

Current Limiting and Short-Circuit Protection

The current limit circuitry prevents damage to the MOSFET switch and the hub downstream port but can deliver load current up to the current limit threshold of typically 150mA through the switch. When a heavy load or short circuit is applied to an enabled switch, a large transient current may flow until the current limit circuitry responds. Once this current limit threshold is exceeded the device enters constant current mode until the thermal shutdown occurs or the fault is removed.

APPLICATION INFORMATION:**● Input Capacitor Selection**

Like any low-dropout regulator, the external capacitors used with the LW64XX Series must be carefully selected for regulator stability and performance. Using a capacitor whose value is $\geq 1\mu\text{F}$ on the LW64XX Series input and the amount of capacitance can be increased without limit. The input capacitor must be located a distance of not more than 0.5 inch from the input pin of the IC and returned to a clean analog ground. Any good quality ceramic or tantalum can be used for this capacitor. The capacitor with larger value and lower ESR (equivalent series resistance) provides better PSRR and line-transient response.

● Layout considerations

To improve ac performance such as PSRR, output noise, and transient response, it is recommended that the PCB be designed with separate ground planes for VIN and VOUT, with each ground plane connected only at the GND pin of the device.

● Output Capacitor Selection

The output capacitor must meet both requirements for minimum amount of capacitance and ESR in all LDOs application. The LW64XX Series is designed specifically to work with low ESR ceramic output capacitor in space-saving and performance consideration. Using a ceramic capacitor whose value is at least $1\mu\text{F}$ on the LW64XX Series output ensures stability. Output capacitor of larger capacitance can reduce noise and improve load transient response, stability, and PSRR. The output capacitor should be located not more than 0.5 inch from the VOUT pin of the LW64XX Series and returned to a clean analog ground.

TYPICAL OPERATING CHARACTERISTICS:

(Tested under $T_A = 25^\circ\text{C}$, $C_{IN} = C_{OUT} = 1\mu\text{F}$, unless otherwise specified)

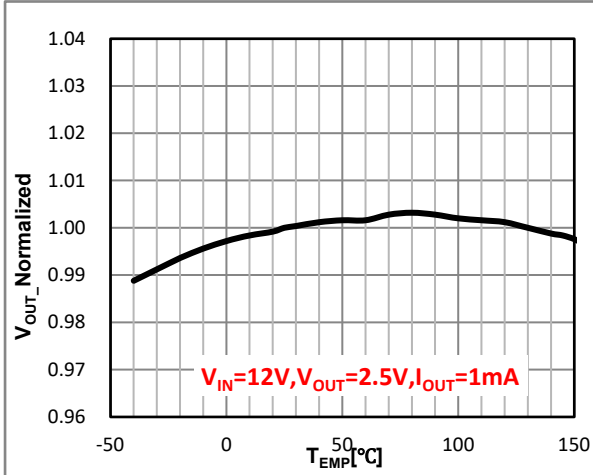

Figure 1. V_{OUT} vs Temperature

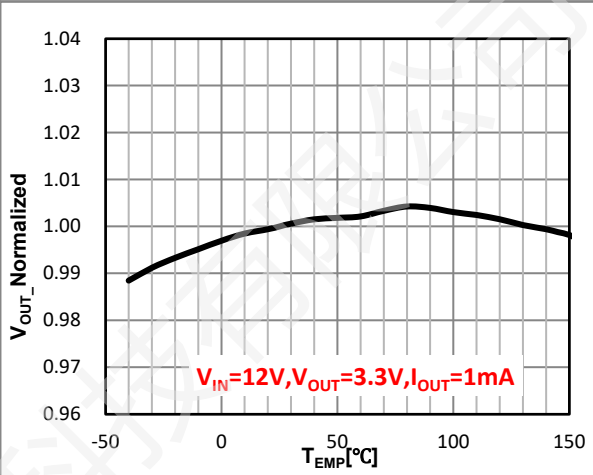

Figure 2. V_{OUT} vs Temperature

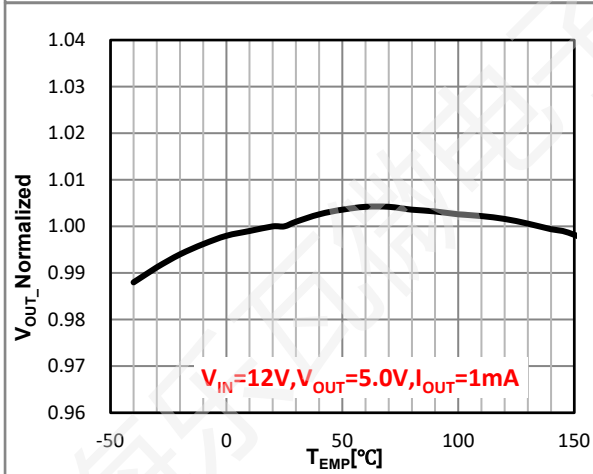

Figure 3. V_{OUT} vs Temperature

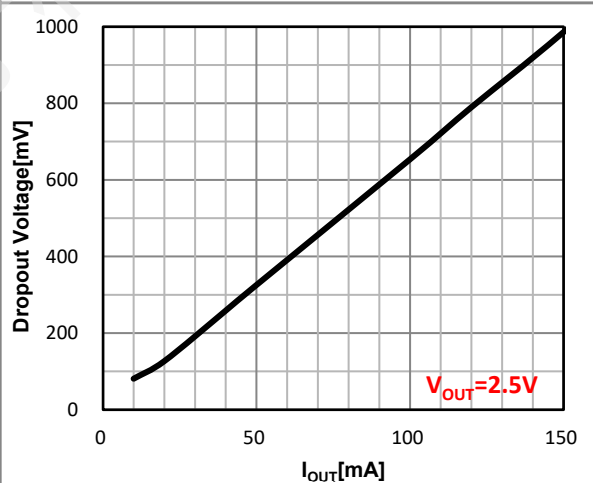

Figure 4. Dropout Voltage VS I_{OUT}

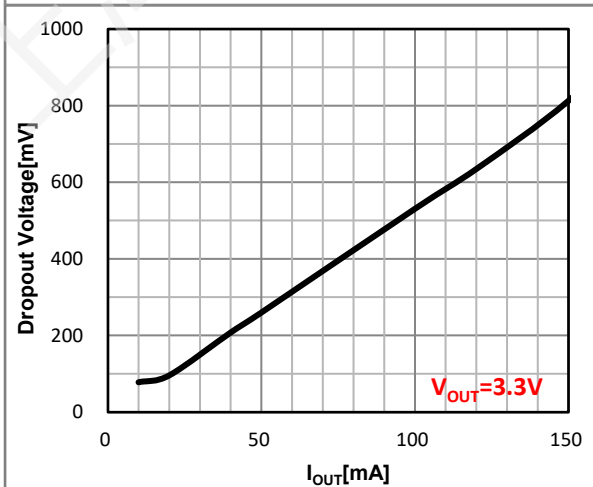

Figure 5. Dropout Voltage VS I_{OUT}

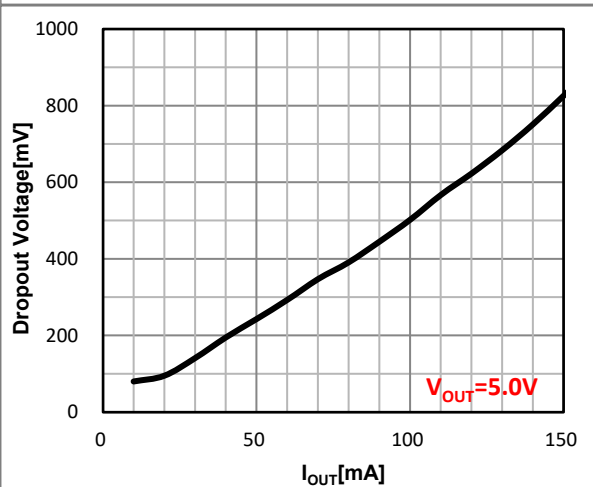

Figure 6. Dropout Voltage VS I_{OUT}

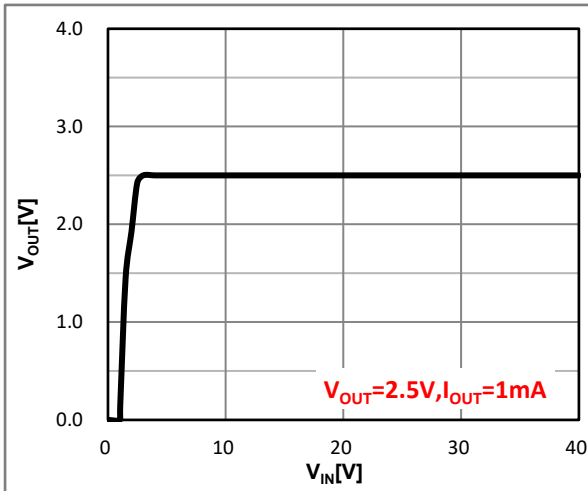

Figure 7. V_{OUT} vs V_{IN}

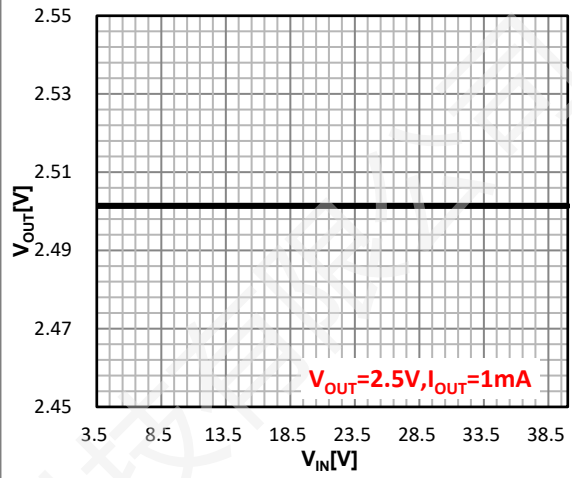

Figure 8. Line Regulation

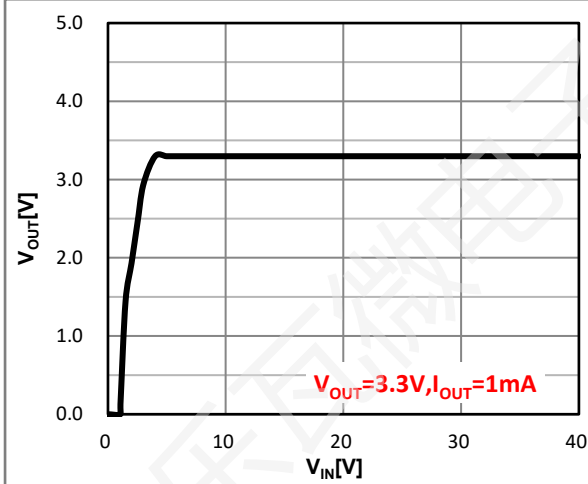

Figure 9. V_{OUT} vs V_{IN}

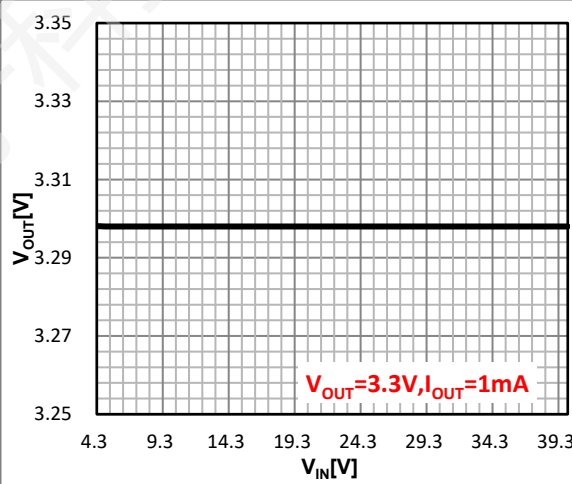

Figure 10. Line Regulation

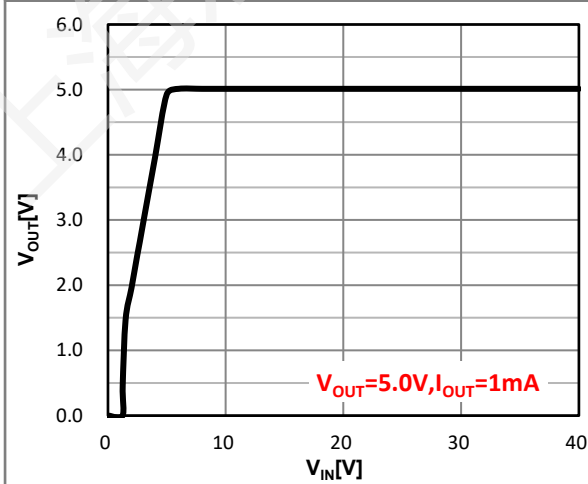

Figure 11. V_{OUT} vs V_{IN}

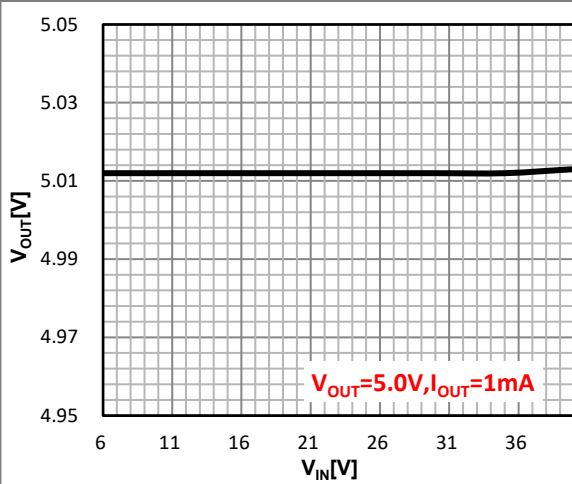

Figure 12. Line Regulation

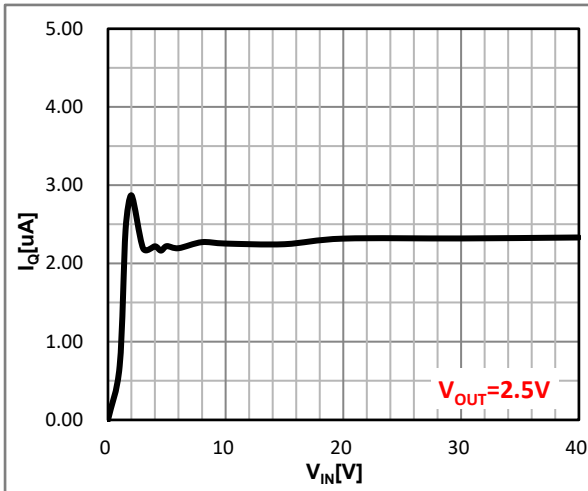

Figure 13. I_Q vs V_{IN}

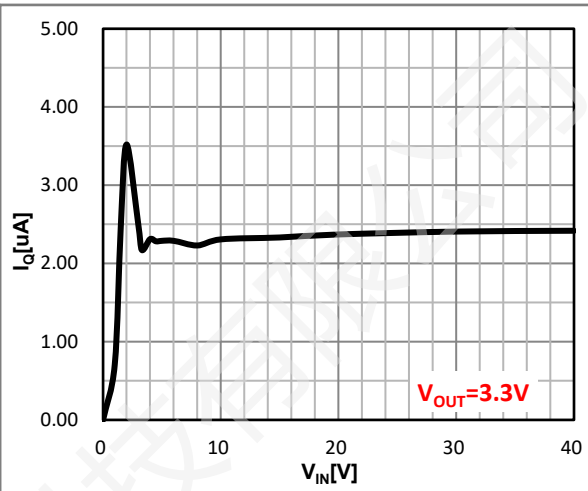

Figure 14. I_Q vs V_{IN}

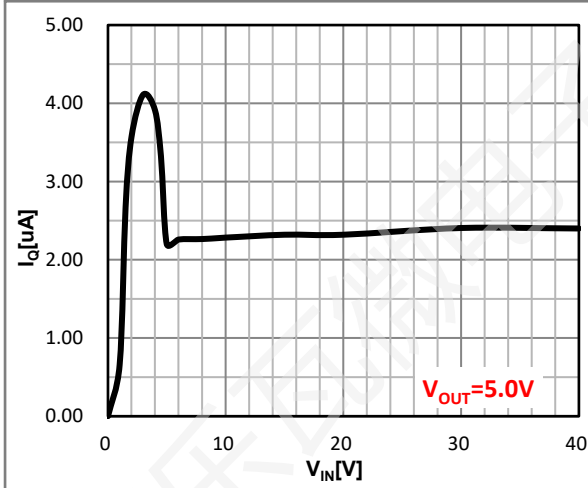

Figure 15. I_Q vs V_{IN}

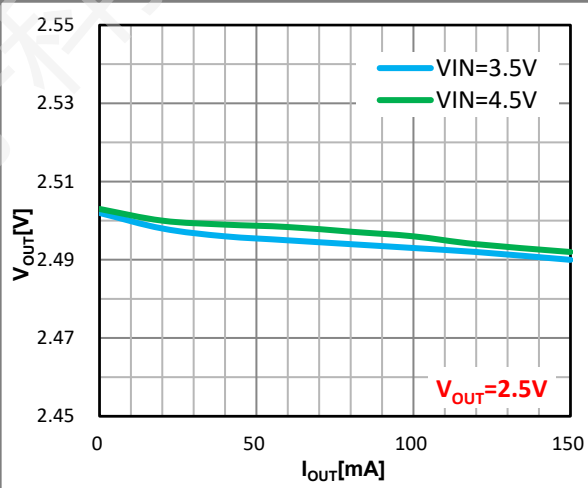

Figure 16. Load Regulation

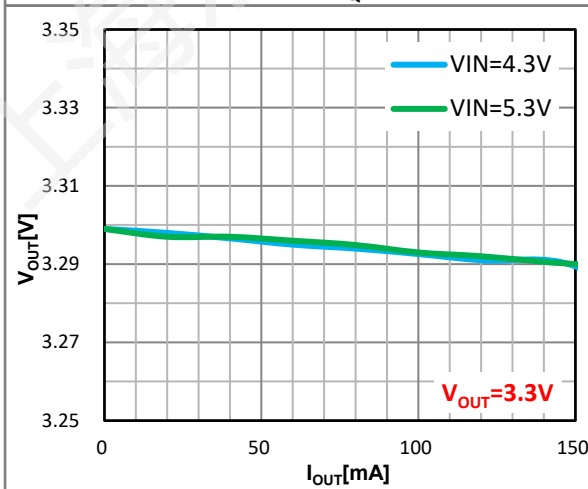

Figure 17. Load Regulation

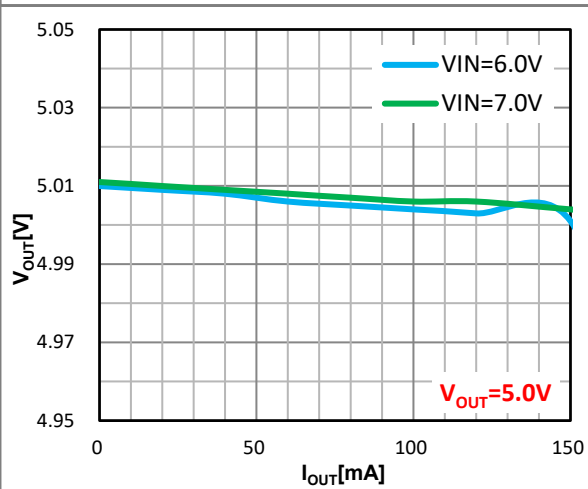
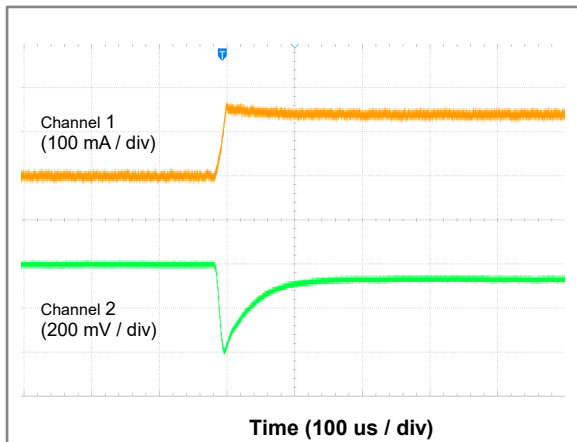
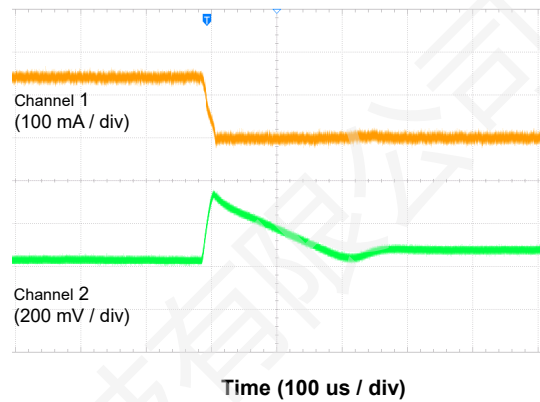

Figure 18. Load Regulation



Channel 1 = I_{OUT} , channel 2 = V_{OUT} , $V_{IN}=3.5V$, $V_{OUT}=2.5V$

Figure 19. Load Transient (1 mA to 150 mA)



Channel 1 = I_{OUT} , channel 2 = V_{OUT} , $V_{IN}=3.5V$, $V_{OUT}=2.5V$

Figure 20. Load Transient (150 mA to 1 mA)

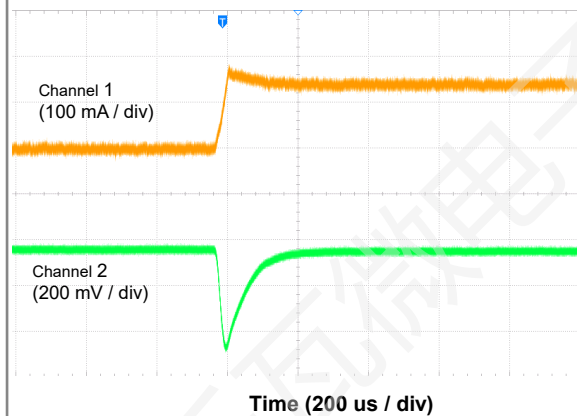

Channel 1 = I_{OUT} , channel 2 = V_{OUT} , $V_{IN}=4.3V$, $V_{OUT}=3.3V$

Figure 21. Load Transient (1 mA to 150 mA)

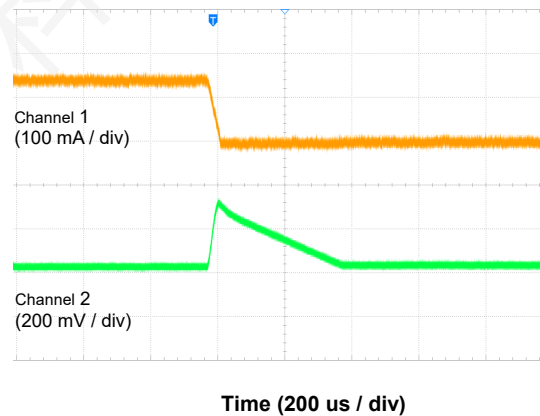

Channel 1 = I_{OUT} , channel 2 = V_{OUT} , $V_{IN}=4.3V$, $V_{OUT}=3.3V$

Figure 22. Load Transient (150 mA to 1 mA)

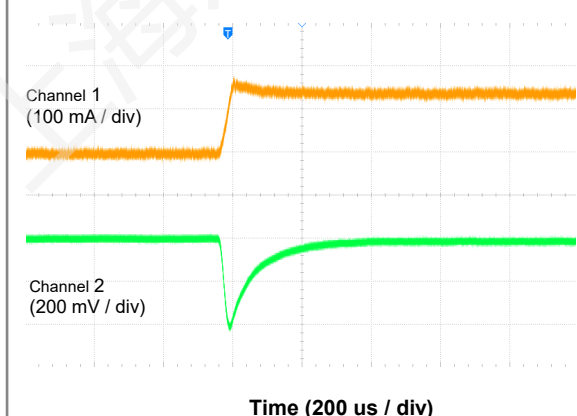

Channel 1 = I_{OUT} , channel 2 = V_{OUT} , $V_{IN}=6.0V$, $V_{OUT}=5.0V$

Figure 23. Load Transient (1 mA to 150 mA)

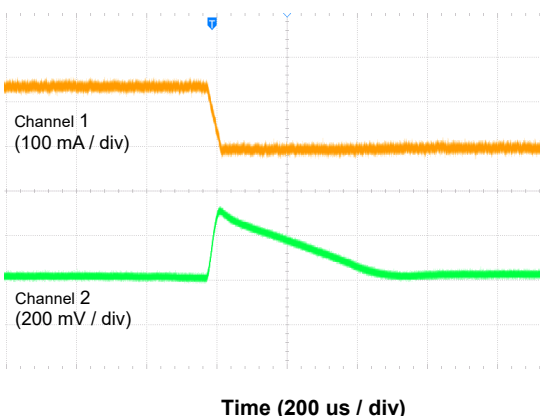

Channel 1 = I_{OUT} , channel 2 = V_{OUT} , $V_{IN}=6.0V$, $V_{OUT}=5.0V$

Figure 24. Load Transient (150 mA to 1 mA)

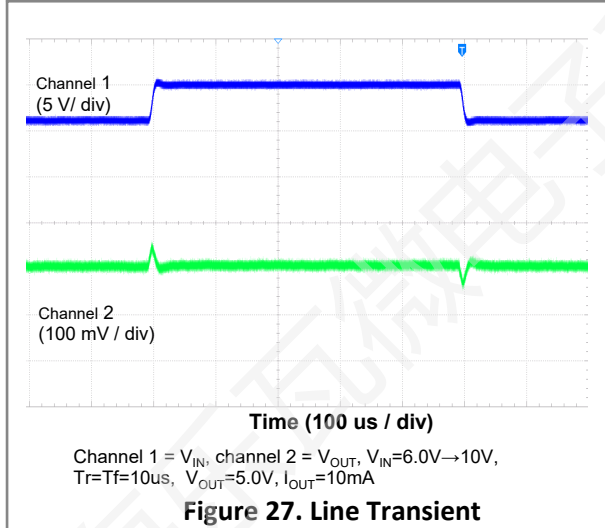
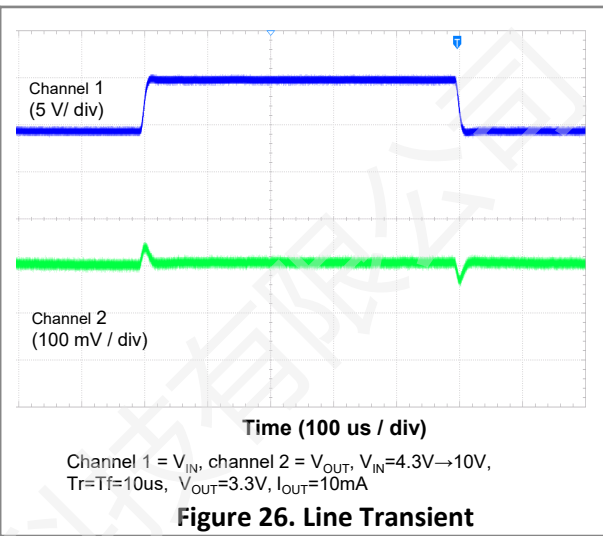
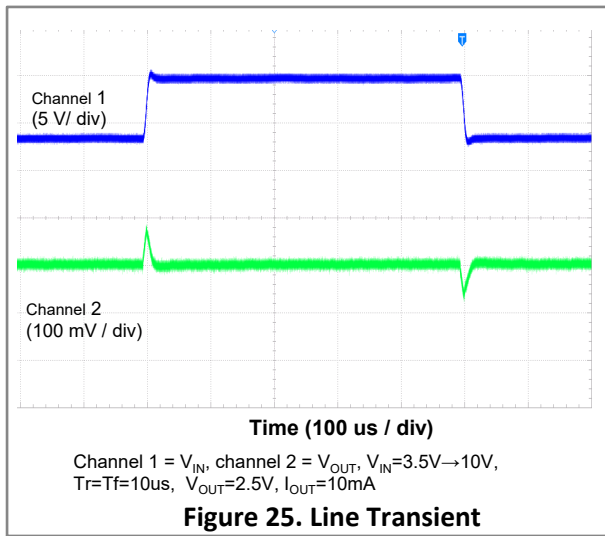

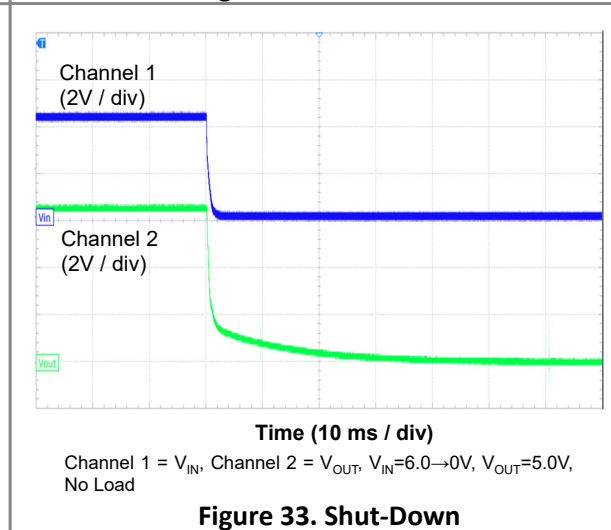
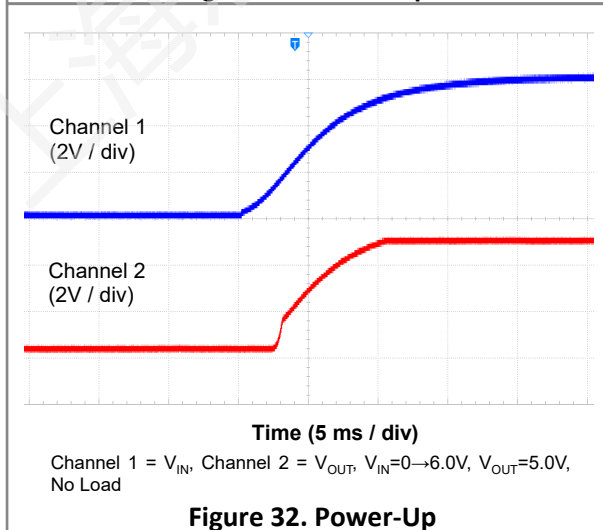
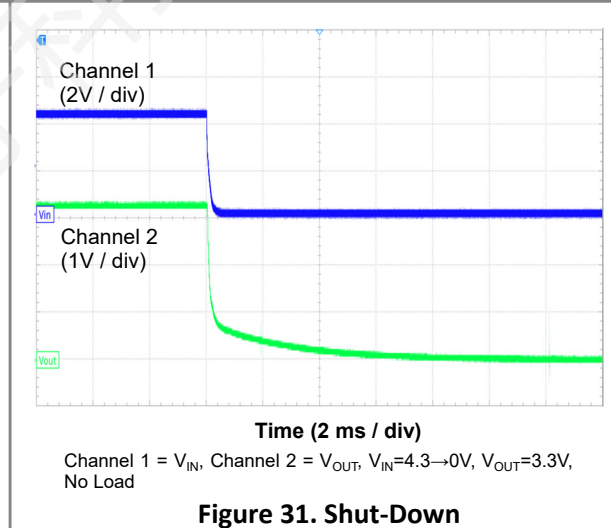
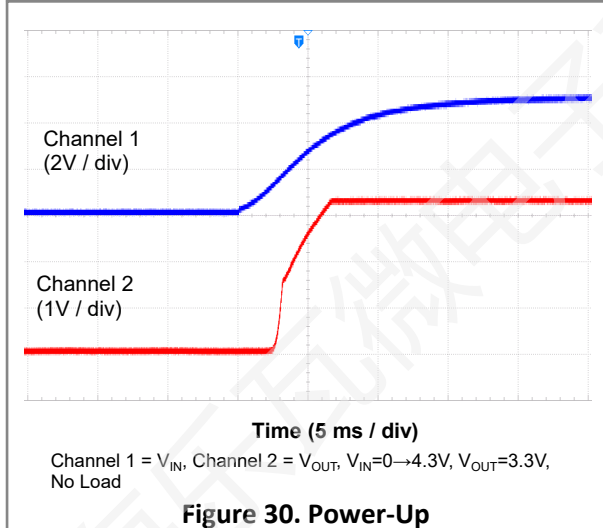
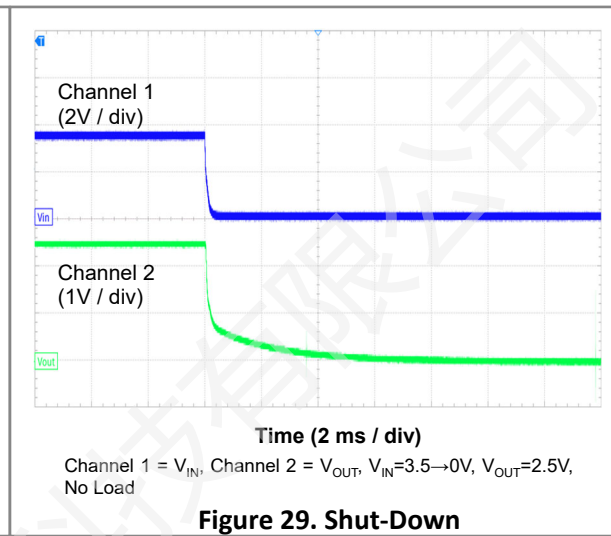
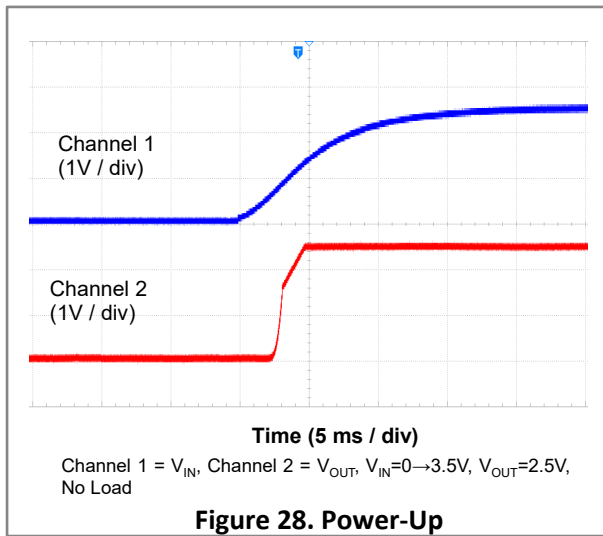

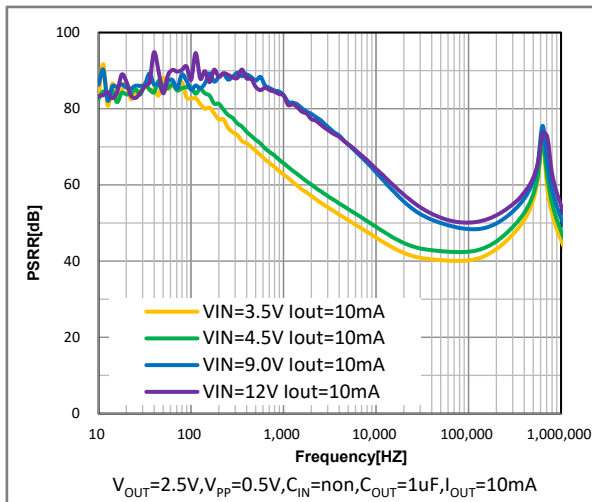

Figure 34. PSRR vs Frequency

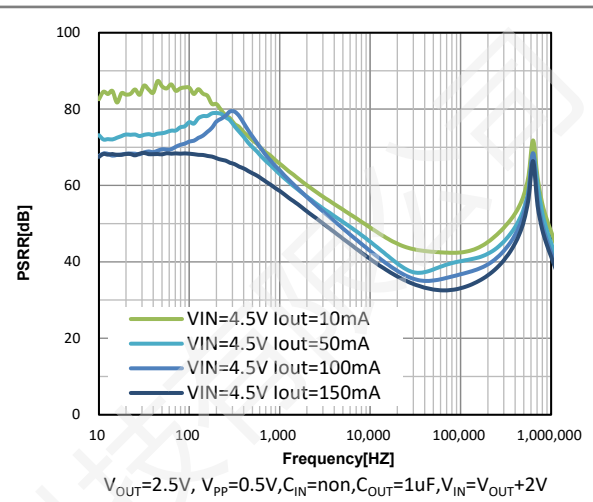

Figure 35. PSRR vs Frequency

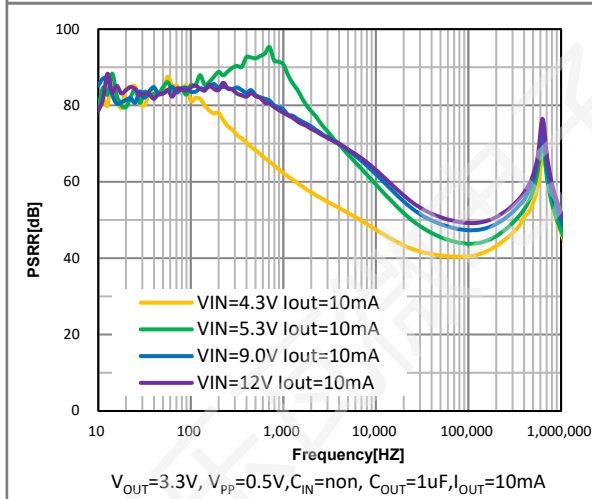

Figure 36. PSRR vs Frequency

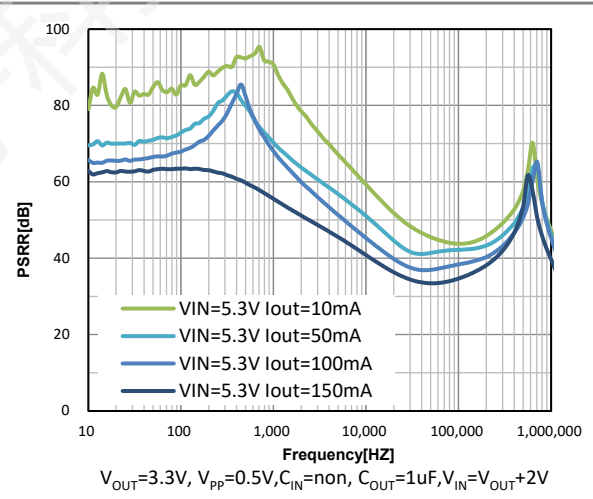

Figure 37. PSRR vs Frequency

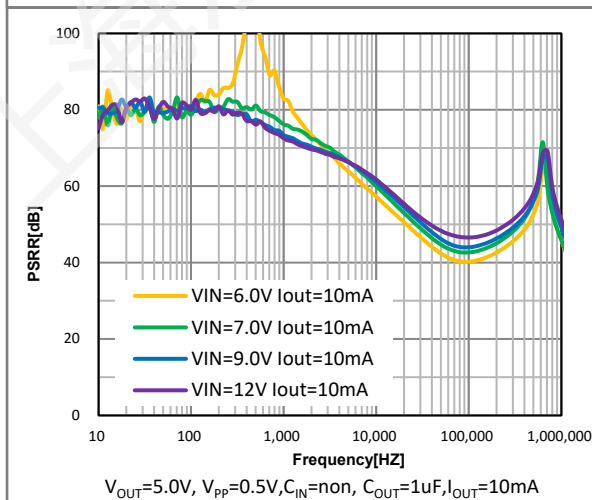

Figure 38. PSRR vs Frequency

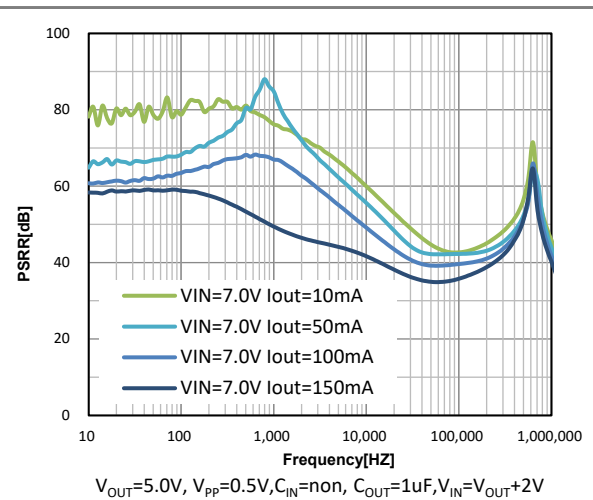
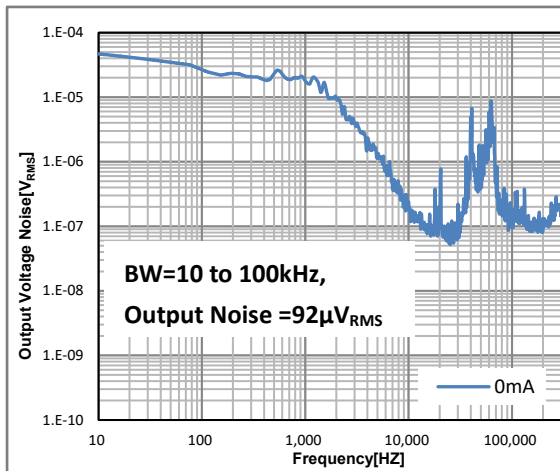
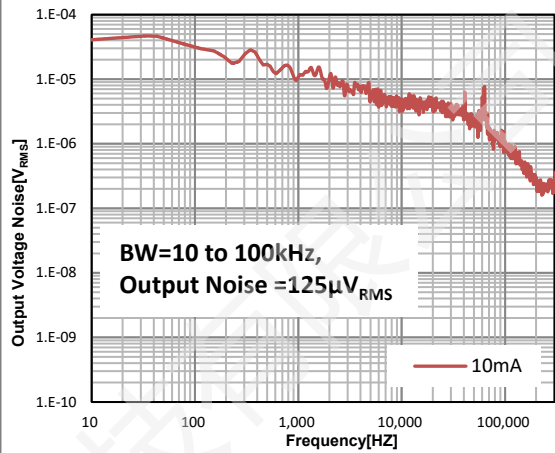

Figure 39. PSRR vs Frequency



$V_{IN}=4.3V, V_{OUT}=3.3V, C_{IN}=1\mu F, C_{OUT}=1\mu F, I_{OUT}=0mA$

Figure 40. Noise vs Frequency



$V_{IN}=4.3V, V_{OUT}=3.3V, C_{IN}=1\mu F, C_{OUT}=1\mu F, I_{OUT}=10mA$

Figure 41. Noise vs Frequency

ORDER INFORMATION:

LW64①②③④⑤⑥

Designator	Item	Symbol	Description
①②	Output Voltage	25~50	e.g.2.8V→①=2,②=8
③④⑤⑥	Packages	N23D	SOT23-3L
		B22G	DFN2x2-6L
		A89C	SOT89-3L(Type-A)
		B89C	SOT89-3L(Type-B)

Part #	Output Voltage	Package	Shipping
LW6425N23D	2.5V	SOT23-3L	3000 Pcs / Tape & Reel
LW6430N23D	3.0V		
LW6433N23D	3.3V		
LW6436N23D	3.6V		
LW6440N23D	4.0V		
LW6442N23D	4.2V		
LW6450N23D	5.0V		
LW6425B22G	2.5V	DFN2x2-6L	3000 Pcs / Tape & Reel
LW6430B22G	3.0V		
LW6433B22G	3.3V		
LW6436B22G	3.6V		
LW6440B22G	4.0V		
LW6442B22G	4.2V		
LW6450B22G	5.0V		

Part #	Output Voltage	Package	Shipping
LW6425A89C	2.5V	SOT89-3L (Type-A)	1000 Pcs / Tape & Reel
LW6430A89C	3.0V		
LW6433A89C	3.3V		
LW6436A89C	3.6V		
LW6440A89C	4.0V		
LW6442A89C	4.2V		
LW6450A89C	5.0V		
LW6425B89C	2.5V	SOT89-3L (Type-B)	1000 Pcs / Tape & Reel
LW6430B89C	3.0V		
LW6433B89C	3.3V		
LW6436B89C	3.6V		
LW6440B89C	4.0V		
LW6442B89C	4.2V		
LW6450B89C	5.0V		

If customers have special output voltage requirements, please contact us.

PACKAGE OUTLINE:

SOT23-3L Package

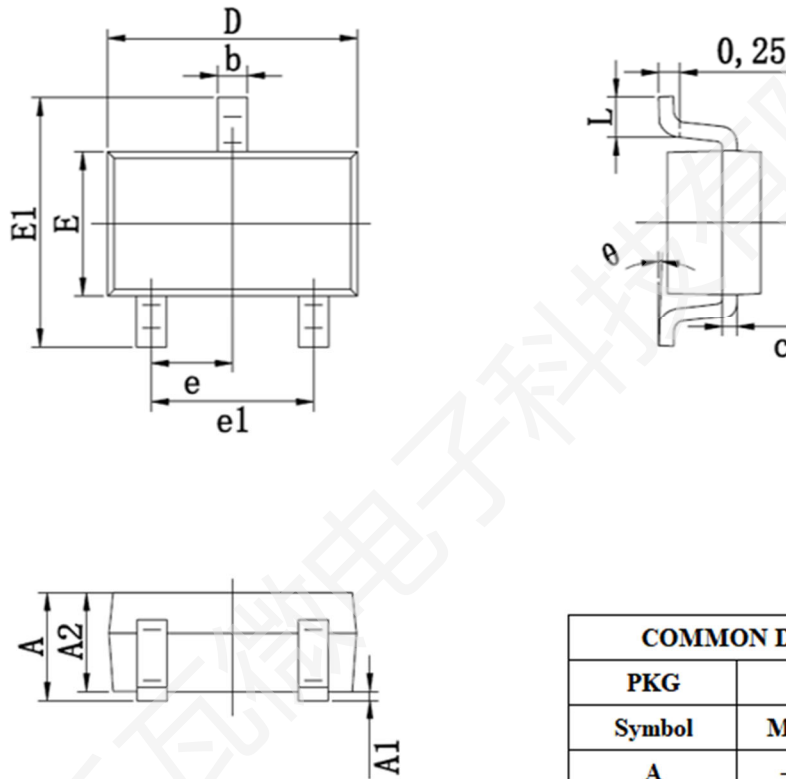

COMMON DIMENSION (MM)			
PKG	SOT23-3L		
Symbol	MIN	NOM	MAX
A	—	—	1.300
A1	0.010	—	0.150
A2	1.050	1.100	1.150
b	0.300	0.350	0.400
c	0.125	0.150	0.175
D	2.870	2.920	2.980
E	1.550	1.610	1.670
E1	2.650	2.850	3.000
e	0.95 BSC		
e1	1.800	1.900	2.000
L	0.300	0.450	0.600
θ	0°	4°	8°

DFN2x2-6L Package

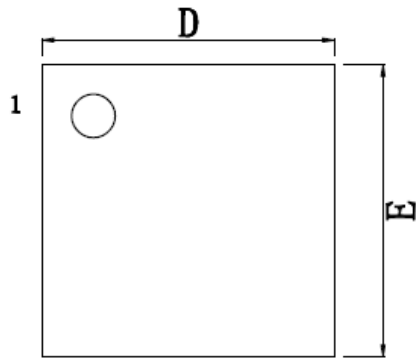

俯视图

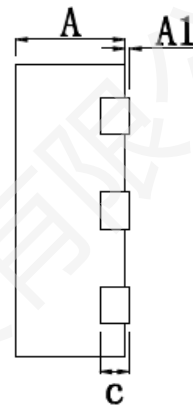

侧视图

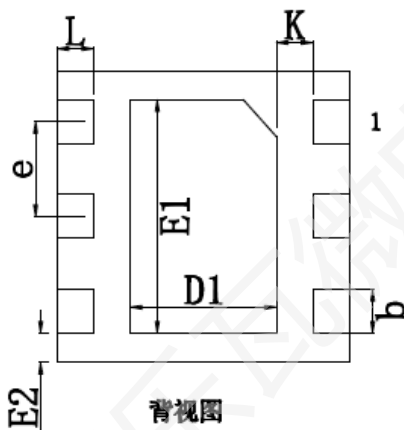

背视图

SYMBOL	MILLMETER		
	MIN	NOM	MAX
A	0.70	0.75	0.80
A1	0.00	—	0.05
b	0.25	0.30	0.35
c	0.203 TYP		
D	1.95	2.00	2.05
D1	0.90	1.00	1.10
E	1.95	2.00	2.05
E1	1.55	1.60	1.65
E2	0.20 REF		
e	0.65 BSC		
K	0.25 REF		
L	0.20	0.25	0.30

SOT89-3L Package

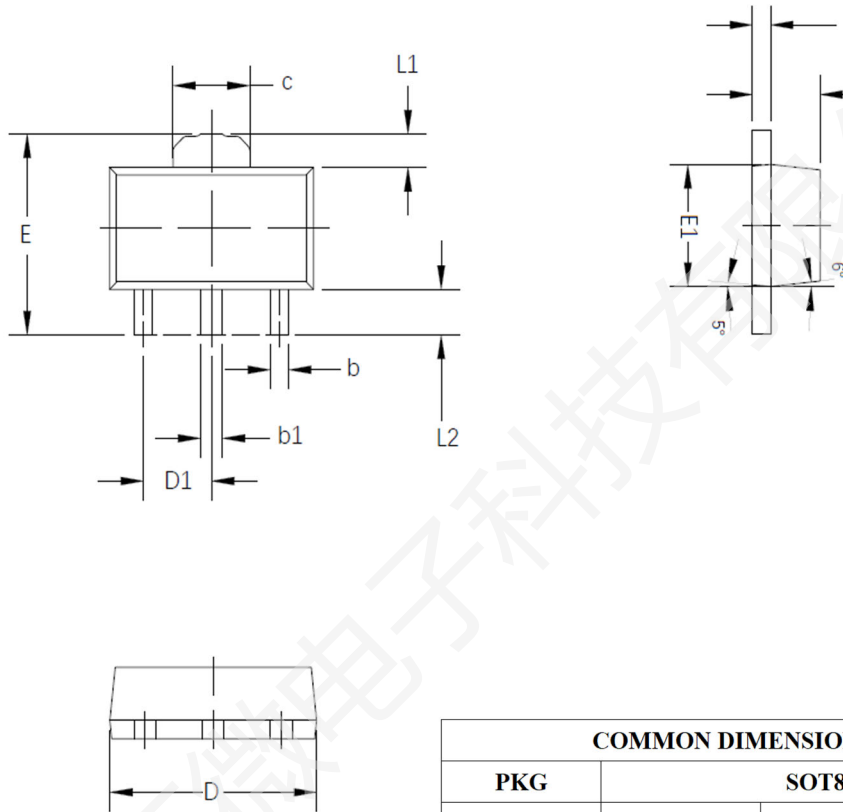

COMMON DIMENSION (MM)

PKG	SOT89-3L		
Symbol	MIN	NOM	MAX
A	1.450	1.500	1.550
A1	0.350	0.400	0.450
b	0.350	0.430	0.500
b1	0.430	0.500	0.570
C	1.650	1.700	1.750
D	4.450	4.550	4.700
D1	1.470	1.500	1.550
E	4.100	4.200	4.300
E1	2.450	2.550	2.650
L1	0.630	0.700	0.770
L2	0.900	0.950	1.000

Revision History:

Revision	Date	Descriptions
Rev 0.1	Aug.2025	Initial Version
Rev 1.0	Sep.2025	Formal Version
Rev 1.1	Jan.2026	Update Eletrical Characteristics
Rev 1.2	Feb.2026	Update Features & Eletrical Characteristics
Rev 1.3	May.2026	Add New Package

DISCLAIMER:

- The product is not intended for use in applications that require extraordinary levels of quality and reliability, such as military, aviation/aerospace and life-support systems or other applications whose failure can be reasonably expected to result in serious physical or material damage.
- Lewa-Micro assumes no responsibility for equipment failures that result from using products at parameters that exceed, even momentarily, rated values (such as maximum ratings, operating condition ranges, or other parameters) listed in products specifications of any Lewa-Micro products described or contained herein.
- Specifications of any and all Lewa-Micro products described or contained herein stipulate the performance, characteristics, and functions of the described products in the independent state, and are not guarantees of the performance, characteristics, and functions of the described products as mounted in the customer's products or equipment. To verify symptoms and states that cannot be evaluated in an independent device, the customer should always evaluate and test devices mounted in the customer's products or equipment.
- Lewa-Micro strives to supply high-quality and high-reliability products. However, any and all semiconductor products have a certain probability of failure. It is possible that these probabilistic failures could give rise to accidents or events that could endanger human lives, that could give rise to smoke or fire, or that could cause damage to other property. When designing equipment, adopt safety measures so that these kinds of accidents or events cannot occur. Such measures including but not limited to protective circuits and error prevention circuits for safe design, redundant design, and structural design.
- To comply with the compliance requirements of relevant export control laws and regulations, if any Lewa-Micro product (including technical data and services) stated herein is subject to relevant export control laws and regulations, it is recommended that the customer apply for and obtain an export license from the competent authority in advance in accordance with the requirements of relevant laws, and do not conduct export activities without obtaining the license. If the customer fails to comply with the aforementioned compliance requirements, all legal liabilities arising therefrom shall be borne solely by the customer.
- To protect Lewa-Micro's intellectual property rights and the security of commercial information, without the prior written permission of Lewa-Micro, no part of this document shall be reproduced or disseminated in any form or by any means (including photocopying, recording, and other electronic or mechanical means, as well as various information storage and retrieval systems). For unauthorized reproduction or dissemination, Lewa-Micro reserves the right to pursue legal liability.
- Information (including circuit diagrams and circuit parameters) herein is for example only; it is not guaranteed for volume production. Lewa-Micro believes information herein is accurate and reliable, but no guarantees are made or implied regarding its use or any infringements of intellectual property rights or other rights of third parties.
- Any and all information described or contained herein are subject to change without notice due to product/technology improvement, etc.

Mailing Address: Unit 02&04&05, 10th Floor, Building 5, No.666 Shengxia Road, No.122 Yindong Road,
China (Shanghai) Pilot Free Trade Zone
Shanghai Lewa Micro-electronics Technology Co., Ltd