

为您的产品保驾护航

PRODUCT DATASHEET

Nano Fuse · Surface Mount

JFC0603LS Series Fuse



Description

The JFC0603LS Series is low resistance Fast-Acting fuse, Ultra small (0603size) thin-film device designed for secondary protection of circuits used in space constrained applications such as hand-held portable electronic devices. This series is 100% lead-free and meets the requirements of the RoHS directive.

Agency Approvals

AGENCY	AGENCY FILE NUMBER
	E486200

Features

- Fast acting for excessive current
- Compatible with reflow and wave solder
- Excellent environmental performance
- RoHS Compliant, Lead Free & Halogen Free material

Electrical Characteristics

% of Ampere Rating	Opening Time at 25°C
100%	4 hours Min.
200%	5 sec. Max.
300%	0.2 sec. Max.

Applications

- Cell phones
- Battery packs
- Digital cameras
- DVD players
- Hard disk drives

Performance Specification

Part No.	Rated Voltage DC(Vdc)	Rated Current (A)	Interrupting Rating* AC/DC	Typical Cold Resistance (ohms) **	Typical Melt ² t ³ *** DC (A ² S)	Marking
JFC0603-0200LS	32	0.20	50A	0.44	0.0026	D
JFC0603-0375LS		0.375		0.30	0.0050	E
JFC0603-0500LS		0.50		0.22	0.0086	F
JFC0603-0750LS		0.75		0.17	0.016	G
JFC0603-1100LS		1.0		0.075	0.020	H
JFC0603-1150LS		1.5		0.050	0.050	K
JFC0603-1200LS		2.0	0.041	0.021	N	
JFC0603-1250LS		2.5	0.030	0.16	O	
JFC0603-1300LS		3.0	0.026	0.15	P	
JFC0603-1350LS		3.5	0.022	0.20	R	
JFC0603-1400LS		4.0	0.018	0.33	S	
JFC0603-1500LS		5.0	0.015	1.25	T	

*AC Interrupting Rating (Measured at rated voltage with a unity power factor);
 DC interrupting rating (Measured at rated voltage, time constant of less than 50 microseconds, battery source)
 **DC Cold Resistance (Measured at 10% of rated current)
 *** Typical Melting I²t (Measured with a battery bank at rated DC voltage, 35A current, not to exceed IR, time constant of calibrated circuit less than 50 microseconds) Device designed to carry rated current for four hours minimum. An operating current of 75% or less of rated current is recommended, with further derating required at elevated ambient temperatures.

Mechanical Specification

Dimensions:Unit(mm)

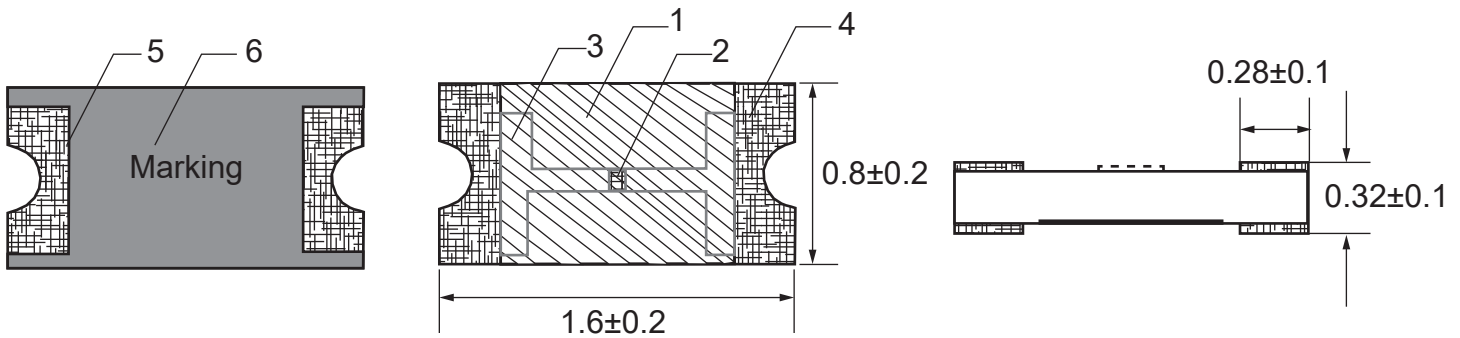

NO.	Component	Material
1	Coating	Epoxy (Green)
2	Fuse Element	Metal Film Fusible Element
3	Inner Electrode	Copper
4	Over plating	Nickel And Tin
5	Substrate	PCB
6	Marking	Epoxy(White)

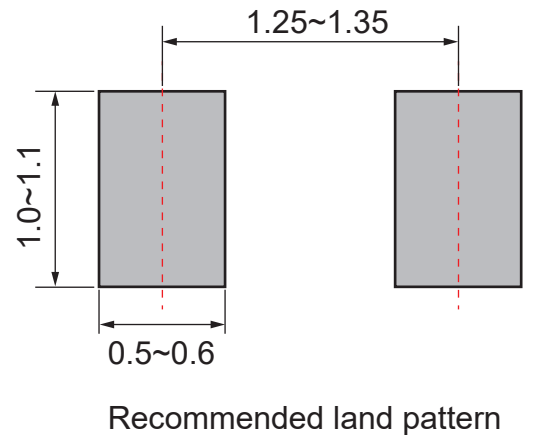

Reliability Test

Item	Contain and Reference standard
Thermal Shock	MIL-STD-202G, Method 107G -65°C~+125°C; Number of cycles :10 times Place for 48±2 hrs at room temp. condition, then measure
Humidity Bias	MIL-STD-202G, Method 103B; 85°C/85%RH. 1000 hours, 10% of operating power. Place for 24±2 hrs at room temp. condition, then measure
Life	Steady State T=30°C ±2°C ,75% rated current, 1000 hours, Place for 24±2 hrs at room temp. condition, then measure
Vibration	MIL-STD-202G, method 204D condition D; 20g, 10-2000Hz, sweep, 4h/direction MIL-STD-202G, Method 210F, Condition B; No pre-heat of samples.
Resistance to Solder Heat	Note: Single Wave Solder
Solderability Test	MIL-STD-202G Method 208H; 4 hours steam aging, One dip at 255 °C for 5s
Terminal Strength (SMD)	AEC-Q200-005; Appendix 2; Note: 1mm (Min)

Environmental Characteristic

- Operating Temperature : -40°C to 90°C
- Storage Temperature:-10°C to 90°C

Temperature Derating Curve

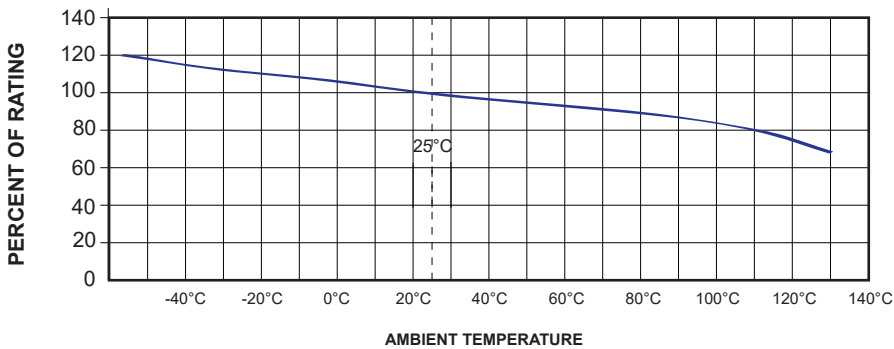

Average Time-Current Curve

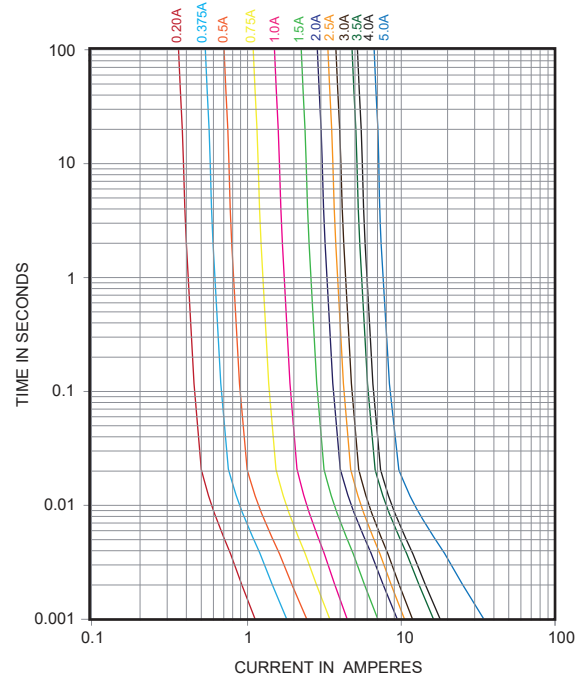

Soldering Parameters

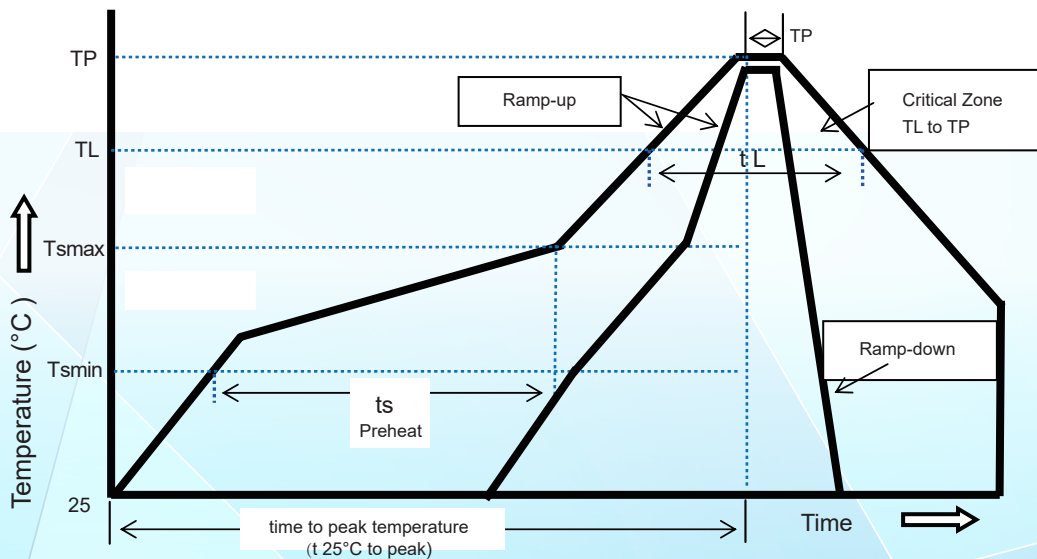

Reflow Condition		Pb-Free assembly
Pre Heat	Temperature Min Ts(min)	150°C
	Temperature Max Ts(max)	200°C
	Time Min to Max (Ts)	60-180 secs
Reflow	Temperature (TL)(Liquidus)	217°C
	Time Max (TL)	60-150 seconds
Average ramp up rate (Liquidus Temp(TL) to peak)		5°C/seconds max
Ts(max)to TL-Ramp-up Rate		5°C/seconds max
Peak Temperature(Tp)		250 + 0/-5°C
Time within 5°C of actual peak Temperature(tp)		20-40 seconds
Ramp-down Rate		5°C/seconds max
Time 5°C of peak Temperature(tp)		8 minutes max
Do not exceed		260°C
Wave Soldering	260°C, 10 seconds max.	

Part Numbering

JFC 0603 - xxxx L S

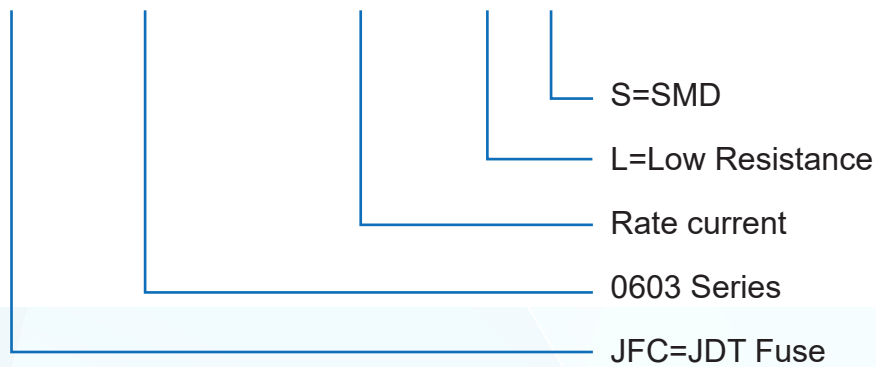

Packaging

Packaging Option	Quantity
8mm Tape and Reel	5000 pcs/reel