

Push switch  
Stroke:0.5±0.2

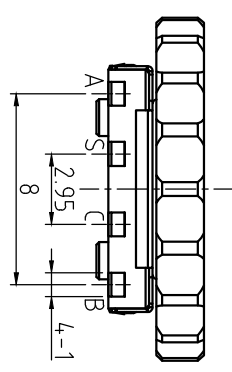

A-C&B-C:ENCODER  
S-C:SLIDE SW  
C:COM

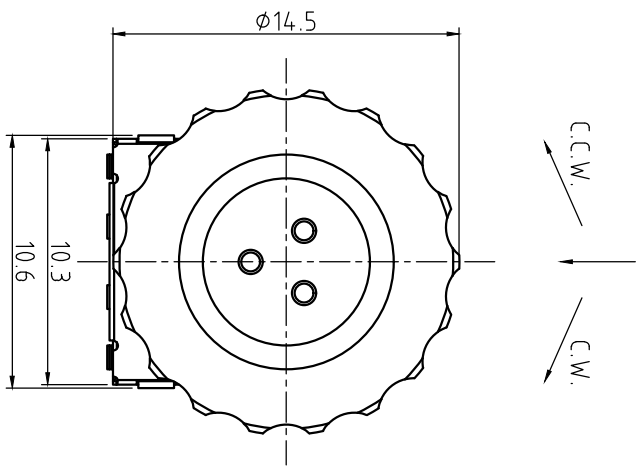
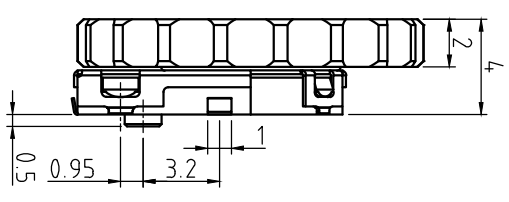

俯视图 (背面)

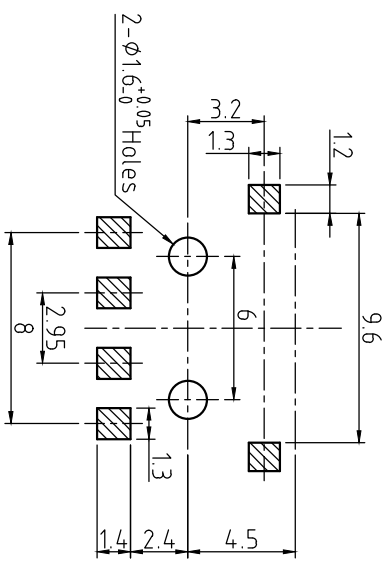
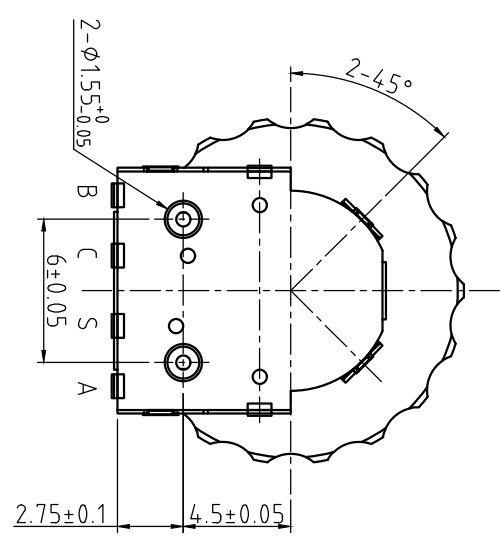

P.C.B. MOUNTING DETAIL

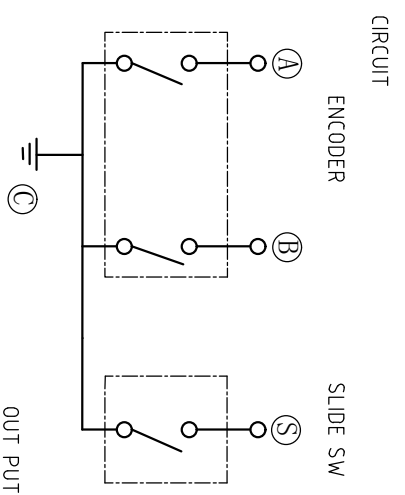

OUT PUT(ENCODER)

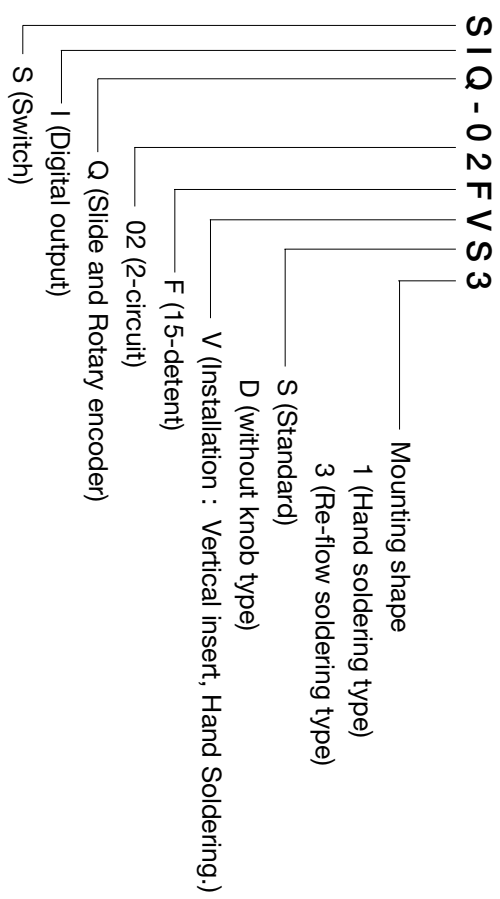
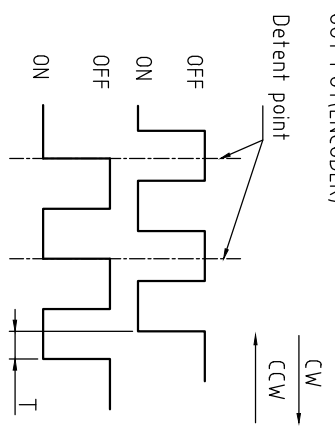

new		2015/5/3		A	
ECN BO.	DESCRIPTION.	DATE.	REV.	瀚源	
DESIGNED	CHECKED	APPROVAL	DRAWING NUMBER	SCALE: 1/2	SCALE: 3:1
Mikey	Tom	Jerry	SIQ-02FVS3	UNLESS OTHERWISE SPECIFIED, TOLERANCE:	X. ±0.25 X.X ±0.20 X.XX ±0.15 ANGULAR ±3°
3RD ANGLE PROJ			SIQ-02FVS3	FILE NO.	
			MODEL NAME	HanElectricity Co.,LTD	
			SIQ-02FVS3		

## 1. 一般事项General

### 1-1. 适用规格 Scope

本规格书适用于微小电流回路的电子设备，属10型回转型编码器。

This specification applies to 10mm size low-profile rotary encoder (incremental type) for microscopic current circuits, used in electronic equipment.

### 1-2. 标准状态Standard atmospheric conditions

除另有规定外，测量应在以下状态下进行：

Unless otherwise specified, the standard range of atmospheric conditions for making measurements and test is as following limits:

温度 Ambient temperature : 5°C to 35°C

相对湿度 Relative humidity : 20% to 85%

气压 Air pressure : 86kpa to 106kpa

如果对在上述所提到的条件中所做的实测值有疑问的话，应使用以下条件进行测量：

If doubt arises on the decision based on the measured values under the above-mentioned conditions, the following conditions shall be employed:

温度 Ambient temperature : 20±2°C

相对湿度 Relative humidity : 60% to 70%

气压 Air pressure : 86kpa to 106kpa

### 1-3. 使用温度范围

Operating temperature range : -20°C to +60°C

### 1-4. 保存温度范围

Storage temperature range : -30°C to +70°C

## 2. 构造Construction

### 2-1. 尺寸 Dimensions

见所附成品图 Refer to attached drawing

## 3. 额定值 Rating

### 3-1. 额定电压

Rated voltage: DC 5V

### 3-2. 最大额定电流 (阻抗负载)

Maximum operating current (resistive load)

各相导线 Each lead: 0.5mA (Max 5mA; Min 0.5mA)

公共导线 Common lead: 1mA (Max 10mA; Min 0.5mA)

## 4. 使用上的事项Application Notes

4-1. 避免储藏于高温潮湿及腐蚀的场所。产品购入后尽可能在6个月内使用完。拆包装后未使用完的剩余

产品需储藏于防潮防毒的环境下。

Avoid storing the products in a place at high temperature, high humidity and in Corrosive gases. Please use this product as soon as possible with 6 months limitation. If any remainder left after packing is opened, please store it with proper moistureproofing, gasproofing etc.

4-2. 编码器信号的计算方法应将操作的速度，信号的取样时间及电子回路中的微电脑软件等考虑进去。

The encoder pulses count method should be designed with taking operating speed, sampling time and design of the microcomputer software into consideration.

4-3. 在设计时要考虑到杂讯，建议使用R/C滤波电路，(图1)

At design of the pulse count process. Using the C/R filter circuit is Recommended. (fig .1)

4-4. 本产品请勿碰触到水，可能会导致输出波形的异常。

Care must be taken not to expose this product to water or dew to prevent possible problem in pluses output waveform.

图1 fig.1

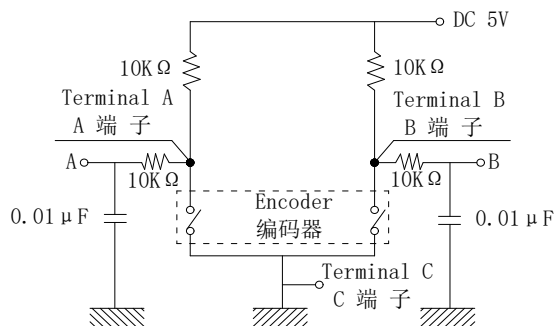

## 5. 电气性能 Electrical Characteristics

项目 ITEM	条件 CONDITIONS	规格 SPECIFICATIONS	
5-1. 输出信号 Output signal format	A、B两信号输出相位差，输出波形详见（图2） 2 Phase-different signals (signal A, signal B) Details shown in<fig.2>		
	轴回转方向 Shaft rotational direction	信号 Signal	输出波形 Output 图2 fig.2
	顺时针方向 C. W	A(A-C端子间) A(TerminalA-C)	OFF ON
	逆时针方向 C. C. W	B(B-C端子间) B(TerminalB-C)	OFF ON
5-2. 分解能力 Resolution	回转360° 的输出脉冲数. Number of pulses in 360° rotation.	15 个脉冲/360° 15pulses/360°	
5-3. 相位差 Phase difference	下（图3）所示回路，轴以360° /s的速度转动测定。 Measurement shall be made under the condition which the shaft is rotated at 360° /s.  A信号(A~C间) signal A  B信号(B~C间) signal B  C. W Direction  图3 fig.3	T1、T2、T3、T4≥5msec 见图3 (fig.3)	
5-4. 开关特性 Switching characteristics	下（图3）所示回路，轴以360° /S的速度转动测定。 Measurement shall be made under the condition as follows. Shaft rotational speed : 360° /S Test circuit : (fig.3)  图3 (fig.3)  图4 (fig.4)  （注）编码OFF指输出电压3.5V以上的状态（图.4）。 Code-OFF area :The area which the voltage is 3.5V or more(fig.4). 编码ON指输出电压1.5V以下的状态（图.4）。 Code-ON area : The area which the voltage is 1.5V or less(fig.4).		

项目 ITEM	条件 CONDITIONS	规格 SPECIFICATIONS
5-4-1. 振荡 Chattering	编码从OFF→ON或ON→OFF时, 输出1.5V~3.5V的通过时间. 应符合规定Specified by the signal's passage time from 1.5V to 3.5V of each switching position(code OFF~ON or ON~OFF)	$t1、t3 \leq 3ms$
5-4-2. 滑动杂讯 (突跳)Sliding noise (Bounce)	编码ON部份的1.5V以上的电压变动时间在振荡 $t1, t3$ 之间会产生1mS以上, 1.5V以下的ON部份. 另外, 如果各突跳1.5V以下的范围在1mS以上时, 则判定为另一个突跳. Specified by the time of voltage change exceed 1.5V in code-ON area . When the bounce has code-ON time less than 1mS between chattering ( $t1$ or $t3$ ) the voltage change shall be regarded as a part of chattering. When the code-ON time between 2 bounces is less than 1mS, they are regarded as 1 linked bounce.	$t2 \leq 2mS$
5-5. 端子间接触阻抗 Contact resistance	输出信号处于ON时安定状态条件下测定. Measurement shall be stable condition which a output signal is ON.	$1 \Omega$ 以下 $1 \Omega$ Max

## 6. 机械性能 Mechanical Characteristics

项目 ITEM	条件 CONDITIONS	规格 SPECIFICATIONS
6-1. 全回转角度 Total rotational angle		$360^\circ$ (无止档点) $360^\circ$ (Endless)
6-2. 定位点力矩 Detent torque	只适用于附卡点装置 Only suitable for C. C, equipment.	$1 \sim 10mN \cdot m$ .
6-3. 定位点数及位置 Number and position of detent	只适用于附卡点装置 Only suitable for C. C, equipment.	■15点定位间隔角度 $24^\circ \pm 2^\circ$ 15 detents Step angle: $24^\circ \pm 2^\circ$
6-4. 开关电路接点数 Switch circuit and number of pulse		单极单投 (按压ON) Single pole and single throw (push ON)
6-5. 开关移动量 Travel of switch		$0.5 \pm 0.2mm$
6-6. 开关动作力 Operation force of switch	在轴端, 沿轴向施加的按压力. Push static load to the shaft in the axial direction	$2 \sim 6N$
6-7. 端子强度 Terminal strength	在端子的先端施加1N (102gf) 的力10秒。 A static load of 1N (102gf) be applied to the tip of terminals for 10sec in any direction.	端子无损坏, 无过度的松动. 允许变形. Without damage or excessive looseness of terminals. terminal bend is permitted.

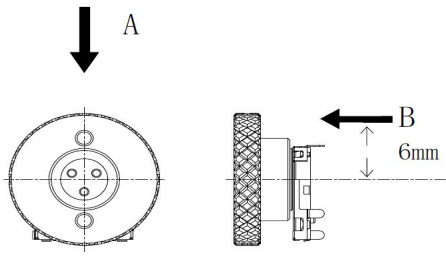
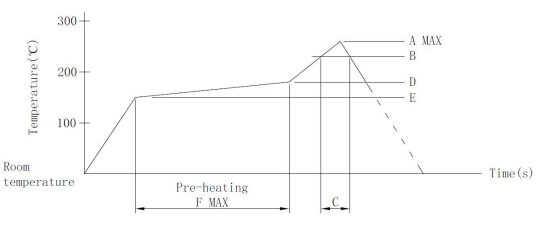
项目 ITEM	条件 CONDITIONS	规格 SPECIFICATIONS												
6-8. 推压强度 Push strength of knob	<p>将旋钮A方向30N (3.06 kgf)、B方向5N (510gf) 的静载荷加10秒钟。(安装在基板上)</p> <p>Push static load of 30N(3.06kgf) shall be applied to the knob in the direction "A" for 10 sec. And push static load of 5N (510gf) shall be applied to the knob in the direction "B" for 10 sec. (After installing)</p> 	<p>满足电气特性，机身无损坏，无明显卡顿。</p> <p>Must fulfill the electrical Specifications. No damage on the body. No significant looseness.</p>												
6-9. 预先加热 Preheat	<p>预热:PBC表明温度180℃以下，时间2±0.3分钟以内</p> <p>Preating must be finished within 2±0.3 minutes to reach Max 180C of copper foil surface after a PCB is placed a reflow soldering furnace.</p>	<p>不得有绝缘体的破损、变形、接触无异常。</p> <p>Electrical characteristics shall be satisfied No mechanical abnormality.</p>												
6-10. 焊锡耐热性 Resistance to Soldering heat	<p>手焊 Manual soldering.            温度250℃以下,时间3秒以内.</p> <p>Bit temperature of soldering iron:250℃less than            Application time of soldering iron:within 3S.</p>  <table border="1" data-bbox="399 1545 941 1624"> <thead> <tr> <th>A (°C) 3s max</th> <th>B (°C)</th> <th>C (s)</th> <th>D (°C)</th> <th>E (°C)</th> <th>F (s)</th> </tr> </thead> <tbody> <tr> <td>250</td> <td>230</td> <td>40</td> <td>180</td> <td>150</td> <td>120</td> </tr> </tbody> </table> <p>(1) 上述条件，为印刷电路板的零部件贴装面上的温度，根据电路板的材质，大小，厚度等，电路板温度和编码器表明温度会有很大的不同,关于编码器表面温度,也请在上述条件内使用。</p> <p>(1) The condition mentioned above is the temperature on the mounting surface of a PC board There are cases where the PC board s temperature greatly differs from that of the encoders depending on the PC boards material, size shall also apply to encoders surfa,thickness, etc. The above-stated conditions ace temperatures.</p> <p>(2) 根据回流槽的种类,条件稍有不同,请事先充分进行确认之后使用。</p> <p>(2) Soldering conditions differ depending on reflow soldering machines. Prior verification of soldering condition is highly recommended.</p>	A (°C) 3s max	B (°C)	C (s)	D (°C)	E (°C)	F (s)	250	230	40	180	150	120	<p>不得有绝缘体的破损、变形、接触无异常。</p> <p>Electrical characteristics shall be satisfied No mechanical abnormality.</p>
A (°C) 3s max	B (°C)	C (s)	D (°C)	E (°C)	F (s)									
250	230	40	180	150	120									

7 耐久性能 Endurance Characteristics					
项目 ITEM	条件 CONDITIONS			规格 SPECIFICATIONS	
7-1. 回转寿命 Rotational life	在无负荷条件下轴以500周/小时速度回转， The shaft of encoder shall be rotated at a speed of 500cycles/H without electrical load, after with measurements shall be made.			50,000±200周。 50,000±200cycles; 满足初始标准值。 Shall not deviate from the previously specified value.	
7-2. 耐湿性 Damp heat	温度40±2℃, 湿度90~95%的恒温恒湿槽中放置96±4 小时后, 在常温、常湿中放置1.5小时后测试。 The encoder shall be stored at temperature of40 ±2℃ with relative humidity of 90% to95% for96±4H in a thermostatic chamber. And the encoder shall be subjected to standard atmospheric conditions for 1.5H, After which measurements shall be made.			端子间接接触阻抗200Ω以下； 开关接触阻抗200mΩ以下；力矩变化率为初 始值的±40%；	
7-3. 耐热性 Dry heat	温度60±2℃的恒温箱中放置96±4小时， 常温、常湿放置1.5小时后测试。 The encoder shall be stored at a temperature of 60±2℃for 96±4H in a thermostatic chamber. And then the encoder. shall be subjected to standard atmospheric conditions for 1.5H, After which measurements shall be made.			按压力变化率为初始值的±30%； Contact resistance 200ΩMax； Switch Contact resistance: 200mΩ or less, Rotation torque change rate shall be within ±40% against initial value； Operation Force of Switch change rate Shall be within±30% against initial value；	
7-4. 低温特性 Cold	温度-20±2℃的恒温箱中放置96±4小时， 常温、常湿放置1.5小时后测试。 The encoder shall be stored at a temperature of -20±2℃for 96±4H in a thermostatic chamber. And then the encoder. shall be subjected to standard atmospheric conditions for 1.5H, After which measurements shall be made.				
受控编号 Document No	修订 Revision	日期 Date	经办 Designed	审核 Check	批准 Approved
	初始发行	2023. 8. 12			
文号 File No					
<b>SIQ系列规格书</b>					
版本 VERSION: A0					