

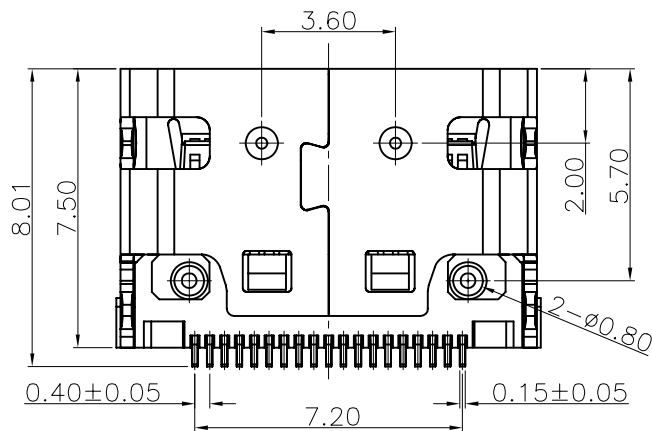

3D VIEW

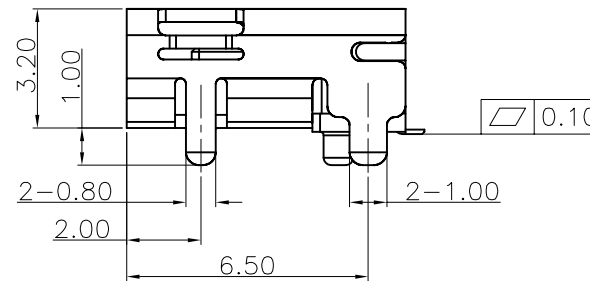
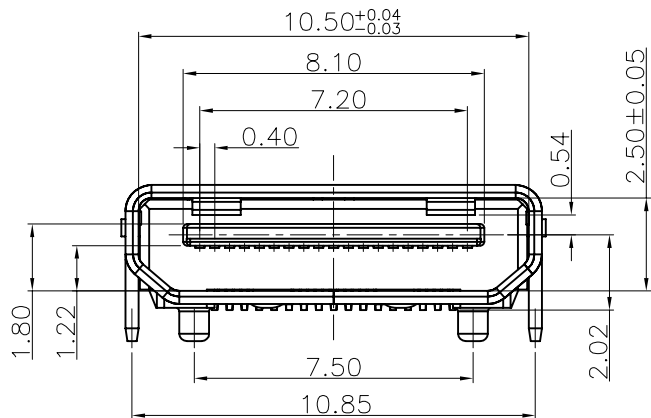

Tolerance Unspecified (未注公差)		Size (图幅): A4	 连兴旺电子(深圳)有限公司 LXWCONN ELECTRONICS (SHENZHEN) CO., LTD
0.0 ±0.15 0° ±5°	Unit (单位): MM	Product Name (产品名称): HDMI C TYPE FEMALE SMT TYPE(HSC SERISE)	
0.00 ±0.10 0°0 ±3°	Scale (比例): 1:1	Product No (产品料号): HHF-122000-2SC	
0.000 ±0.05 0°00 ±1°	Project View (投影视角)	Page (页数): 1 OF 2	
1.0 初版发行	2011/07/02	Chu	Designer (设计): Chu 2011-07-02
Rev 版本	Change Description 变更内容	Date 日期	Revisor 制/修订人
			Checked (审核):
			Approved (核准):

1.0	初版发行	2011/07/02	Chu
Rev 版本	Change Description 变更内容	Date 日期	Revisor 制/修订人

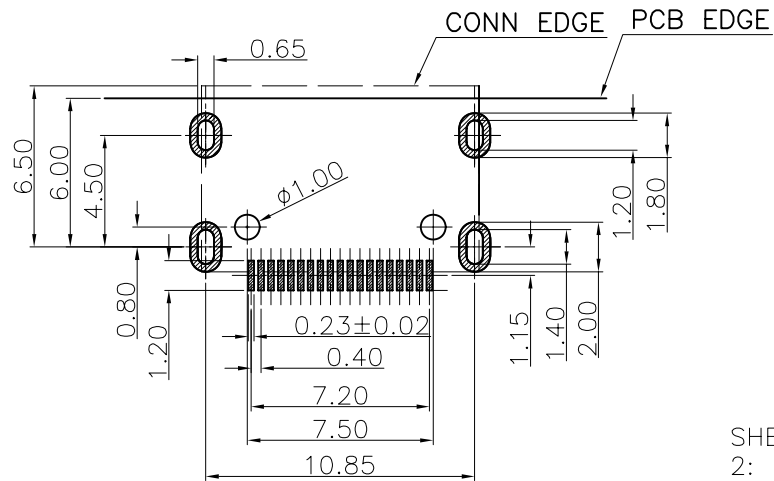

RECOMMENDED PCB LAYOUT(TOP VIEW)
 (THICKNESS=0.8±0.05mm)
 TOLERANCE = ±0.05

PIN	Signal Name	PIN	Signal Name
1	TMDS DATA2 Shield	11	TMDS Clock+
2	TMDS DATA2+	12	TMDS Clock-
3	TMDS DATA2-	13	DDC/CEC Ground
4	TMDS DATA1 Shield	14	CEC
5	TMDS DATA1+	15	SCL
6	TMDS DATA1-	16	SDA
7	TMDS DATA0 Shield	17	Reserved(in cable but N.C.on device)
8	TMDS DATA0+		
9	TMDS DATA0-	18	+5V Power
10	TMDS Clock Shield	19	Hot Plug Detect

NOTES:

- MATERIAL:
 - HOUSING: LCP, BLACK, UL94V-0
 - SHELL: BRASS
 - TERMINAL: PHOSPHOR BRONZE
 - MYLAR:
- PLATING:
 - SHELL: GOLD PLATING OVER NICKEL UNDERPLATED/NICKEL PLATING OVER ALL
 - TERMINAL: GOLD PLATING ON CONTACT AREA AND TIN PLATING ON SOLDER AREA, NICKEL UNDERPLATING OVER ALL
- ALL RAW MATERIAL, COMPONENTS, AND PROCESS MUST MEET HAZARD SUSTAIN FREE PER RoHS & REACH STANDARD.

4. P/N: HHF-12X000-2SC

SHELL MATERIAL & PLATING CODE: 2: MATERIAL: COPPER ALLOY
 NICKEL PLATING WITHOUT FLANGE

PACKAGING CODE: 2: TAPE REEL PACKAGE

TERMINAL CONTACT AREA PLATING CODE:
 1: CONTACT AREA: GOLD FLASH
 SOLDER AREA: GOLD FLASH
 2: CONTACT AREA: 3u" GOLD
 SOLDER AREA: GOLD FLASH
 A: CONTACT AREA: GOLD FLASH
 SOLDER AREA: MATTE TIN 100u"
 B: CONTACT AREA: 3u" GOLD
 SOLDER AREA: MATTE TIN 100u"

Rev	Change Description	Date	Revisor
1.0	初版发行	2011/07/02	Chu
版本	变更内容	日期	制/修订人

CUSTOMER DRAWING		LXW 连兴旺电子(深圳)有限公司 LXWCONN ELECTRONICS (SHENZHEN) CO., LTD	
Tolerance Unspecified (未注公差)	Size (图幅): A4	Product Name (产品名称):	
0.0 ±0.15 0° ±5°	Unit (单位): MM	HDMI C TYPE FEMALE SMT TYPE(HSC SERISE)	
0.00 ±0.10 0°0 ±3°	Scale (比例): 1:1	Product No (产品料号):	
0.000 ±0.05 0°00 ±1°	Page (页数): 2 OF 2	HHF-122000-2SC	
Project View (投影视角)	Rev (版本): A	Designer (设计):	Checked (审核):
		Chu 2011-07-02	Approved (核准):