



# 深圳市佑驰电子有限公司

## Specification for Approval

产品名称: 非晶电感  
规格型号: TOCC-0852-XXX-M  
产品编号:  
日期: 2025-5-09

- 1、本承认书的内容更改需经过双方确认，任一方单独的修改均视为无效。
- 2、本承认书在送达客户后，请给予承认并即签回，如无签回下订单的，我司有权以此承认书标准生产，并表示购买方默认许可。

核准	审核	制作
	Aaron	Ada

REVISION					
REV	DESCRIPTION	DATE	DESIGNED	CHECKED	APPROVED
A0	Initial Release	2025/05/09	Kalyn	Dragon	Darren

## High Current, Power Inductors

### TOCC-0852-4R7-M Power Choke

### TOCC-0852-6R8-M Power Choke



#### Description

- Halogen Free
- 125°C maximum total temperature operation
- 8.4x8.2x 5.2mm maximum surface mount package
- Magnetically shielded, low EMI
- High current carrying capacity, Low core losses
- RoHS compliant

#### Applications

- Voltage Regulator Module (VRM)
- SSD modules
- Notebook regulators
- Battery power systems
- Graphics cards
- Data networking and storage systems

#### Environmental Data

- Storage temperature range: -55°C to +125 °C
- Operating temperature range: -55°C to +125°C (ambient plus self-temperature rise)
- Solder reflow temperature: J-STD-020 compliant

Description			
TOCC-0852-4R7-M	4.7µH	±20 %	
Model	Inductance Value	Inductance Tolerance	
Global Part Number			
T O C C	0 8 5 2	4 R 7	M
Product Series	Dimensions	Inductance Value	Tolerance

Part No.	Inductance	DC Resistance		Heating Rating Current	Saturation Current
	L0 (μH)	DCR (mΩ)		Idc (A)	Isat (A)
	±20 %, 100kHz, 1V	TYP.	MAX.	TYP.	TYP.
TOCC-0852-4R7-M	4.7	8.8	10.5	9.0	10.0
TOCC-0852-6R8-M	6.8	14.0	16.5	8.0	9.0

**Notes**

1. All test data is referenced to 25 °C ambient
2. Operating temperature range - 55 °C to + 125 °C
3. Idc(A):DC current (A) that will cause an approximate ΔT of 40 °C (reference ambient temperature is 25 °C)
4. Isat(A):DC current (A) that will cause L0 to drop approximately 30 %
5. The part temperature (ambient + temp rise) should not exceed 125 °C under worst case operating conditions. Circuit design, component placement, PWB trace size and thickness, airflow and other cooling provisions all affect the part temperature. Part temperature should be verified in the end application.

**• Dimensions-mm**

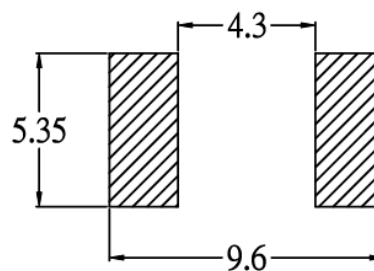
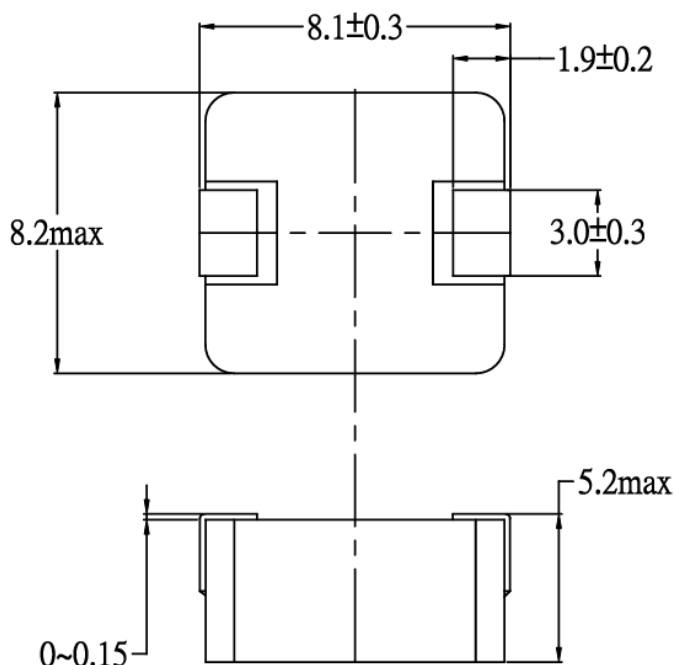

Recommend Land Pattern Dimensions

• **Marking**

The inductor is marked with a 3-digit code

Example -  $-4.7\mu\text{H} \rightarrow 4\text{R}7$

Note : Using Ink for marking

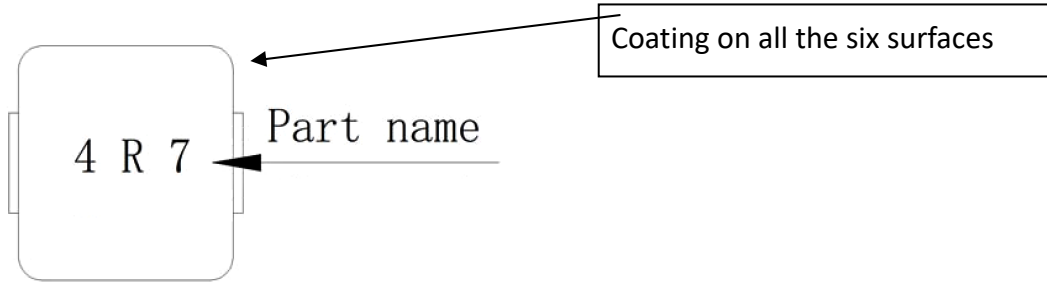

Performance Graphs																																																																			
Test Instruments	Test Condition																																																																		
Wayne kerr 3260B/G LCR Meter Wayne kerr 3265B Bias Current Source	Temperature: $26 \pm 3^\circ\text{C}$ Humidity: $< 70\% \text{ RH}$ Frequency: 100kHz, 1.0V																																																																		
<p style="text-align: center;"><b>TOCC-0852-4R7-M</b></p> <table border="1"> <caption>Data for TOCC-0852-4R7-M</caption> <thead> <tr> <th>DC BIAS (Amps)</th> <th>INDUCTANCE (μH)</th> <th>TEMP RISE (°C)</th> </tr> </thead> <tbody> <tr><td>0</td><td>4.7</td><td>0</td></tr> <tr><td>1.5</td><td>4.2</td><td>5</td></tr> <tr><td>3</td><td>3.8</td><td>10</td></tr> <tr><td>4.5</td><td>3.5</td><td>15</td></tr> <tr><td>6</td><td>3.2</td><td>20</td></tr> <tr><td>7.5</td><td>2.9</td><td>25</td></tr> <tr><td>9</td><td>2.6</td><td>30</td></tr> <tr><td>10.5</td><td>2.4</td><td>35</td></tr> <tr><td>12</td><td>2.2</td><td>40</td></tr> <tr><td>13.5</td><td>2.1</td><td>45</td></tr> <tr><td>15</td><td>2.0</td><td>50</td></tr> </tbody> </table>	DC BIAS (Amps)	INDUCTANCE (μH)	TEMP RISE (°C)	0	4.7	0	1.5	4.2	5	3	3.8	10	4.5	3.5	15	6	3.2	20	7.5	2.9	25	9	2.6	30	10.5	2.4	35	12	2.2	40	13.5	2.1	45	15	2.0	50	<p style="text-align: center;"><b>TOCC-0852-6R8-M-A</b></p> <table border="1"> <caption>Data for TOCC-0852-6R8-M-A</caption> <thead> <tr> <th>DC BIAS (Amps)</th> <th>INDUCTANCE (μH)</th> <th>TEMP RISE (°C)</th> </tr> </thead> <tbody> <tr><td>0</td><td>6.8</td><td>0</td></tr> <tr><td>2</td><td>6.2</td><td>5</td></tr> <tr><td>4</td><td>5.6</td><td>10</td></tr> <tr><td>6</td><td>5.0</td><td>15</td></tr> <tr><td>8</td><td>4.4</td><td>20</td></tr> <tr><td>10</td><td>3.8</td><td>25</td></tr> <tr><td>12</td><td>3.2</td><td>30</td></tr> <tr><td>14</td><td>2.6</td><td>35</td></tr> <tr><td>16</td><td>2.2</td><td>40</td></tr> </tbody> </table>	DC BIAS (Amps)	INDUCTANCE (μH)	TEMP RISE (°C)	0	6.8	0	2	6.2	5	4	5.6	10	6	5.0	15	8	4.4	20	10	3.8	25	12	3.2	30	14	2.6	35	16	2.2	40
DC BIAS (Amps)	INDUCTANCE (μH)	TEMP RISE (°C)																																																																	
0	4.7	0																																																																	
1.5	4.2	5																																																																	
3	3.8	10																																																																	
4.5	3.5	15																																																																	
6	3.2	20																																																																	
7.5	2.9	25																																																																	
9	2.6	30																																																																	
10.5	2.4	35																																																																	
12	2.2	40																																																																	
13.5	2.1	45																																																																	
15	2.0	50																																																																	
DC BIAS (Amps)	INDUCTANCE (μH)	TEMP RISE (°C)																																																																	
0	6.8	0																																																																	
2	6.2	5																																																																	
4	5.6	10																																																																	
6	5.0	15																																																																	
8	4.4	20																																																																	
10	3.8	25																																																																	
12	3.2	30																																																																	
14	2.6	35																																																																	
16	2.2	40																																																																	

Mechanical Reliability			
No.	Item	Specification and Requirement	Test Method
1	Solderability	The surface of terminal immersed shall be minimum of 95% covered with a new coating of solder	Retention time: $245 \pm 5$ °C for 5+0/-0.5seconds;
2	Resistance to Soldering Heat	Change from an initial value Inductance:within $\pm 10\%$	Retention time: within 30 seconds $255 \pm 5$ °C , Three Times;
3	Terminal Strength	No electrode detachment	No electrode detachment should be found when the device is pushed in two directions of X and Y with the force of 17.7N for 60 seconds after soldering between copper plate and the electrodes;
4	Vibration	Inductance change: Within $\pm 10\%$ Without mechanical damage such as break	1. Vibration frequency: (10 Hz to 2000 Hz to 10Hz) in 20 minutes as a period; 2. Vibration time: Period cycled for four hours in each of 3 mutual perpendicular directions. 3. Amplitude: 1.5 mm max.
5	Mechanical Shock	Inductance change: Within $\pm 10\%$ Without mechanical damage such as break	1. Peak value: 100 G, Duration of pulse: 6ms 2. 3 times in each positive and negative direction of 3 mutual perpendicular directions;
6	Substrate Bending	Inductance change: Within $\pm 10\%$ Without distinct damage in appearance	1. Bending speed is 0.5mm/sec, 2. While the bending width reaches 2mm, keep it for 60 sec
Endurance Reliability			
No.	Item	Specification and Requirement	Test Method
7	Thermal Shock	Inductance change: Within $\pm 10\%$ Without distinct damage in appearance	Repeat 1000 cycles as follow: ( $-55 \pm 2$ °C; $30 \pm 3$ min)→ ( $+125 \pm 2$ °C , $30 \pm 3$ min)
8	Low Temperature Storage	Inductance change: Within $\pm 10\%$ Without distinct damage in appearance	Store temperature: $-55 \pm 2$ °C, 1000 + 4 / -0 hours;
9	High Temperature Storage	Inductance change: Within $\pm 10\%$ Without distinct damage in appearance	Store temperature: $+125 \pm 2$ °C, 1000 + 4 / -0 hours;
10	High Temperature&Humidity	Inductance change: Within $\pm 10\%$ Without distinct damage in appearance	$85 \pm 2$ °C 85%RH , 1000+4/-0 hours;

Tape Packaging Dimensions

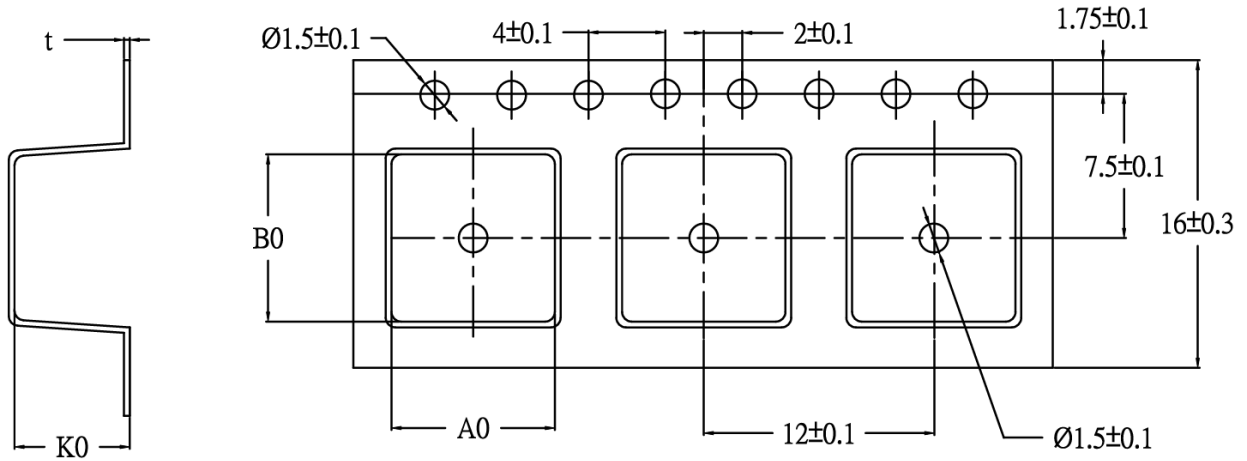

	A0	B0	K0	t	
	$8.5\pm0.1$	$8.7\pm0.1$	$6.0\pm0.15$	$0.5\pm0.05$	

Taping dimension and tape direction ,Leader ,Trailer, section dimension

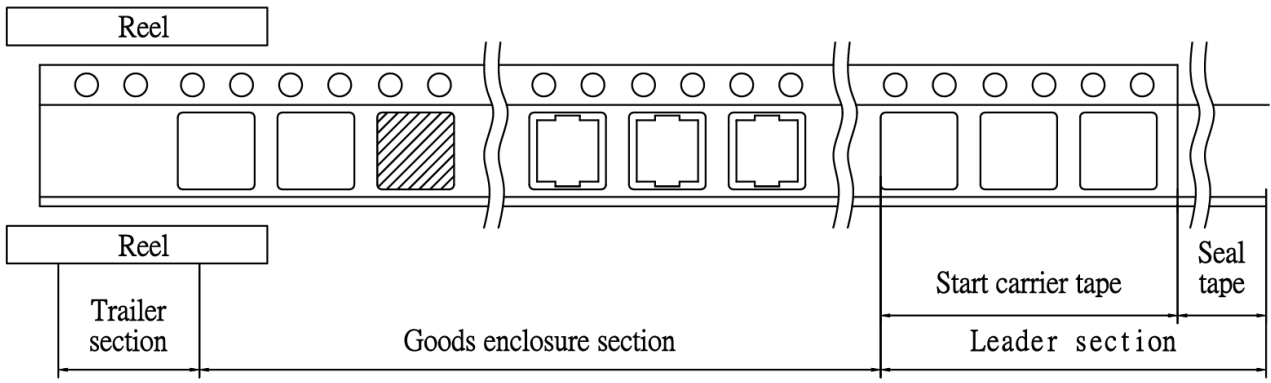

Leader section	Min.400mm
Carrier tape start size	Min.100mm
Trailer section size	Min.160mm

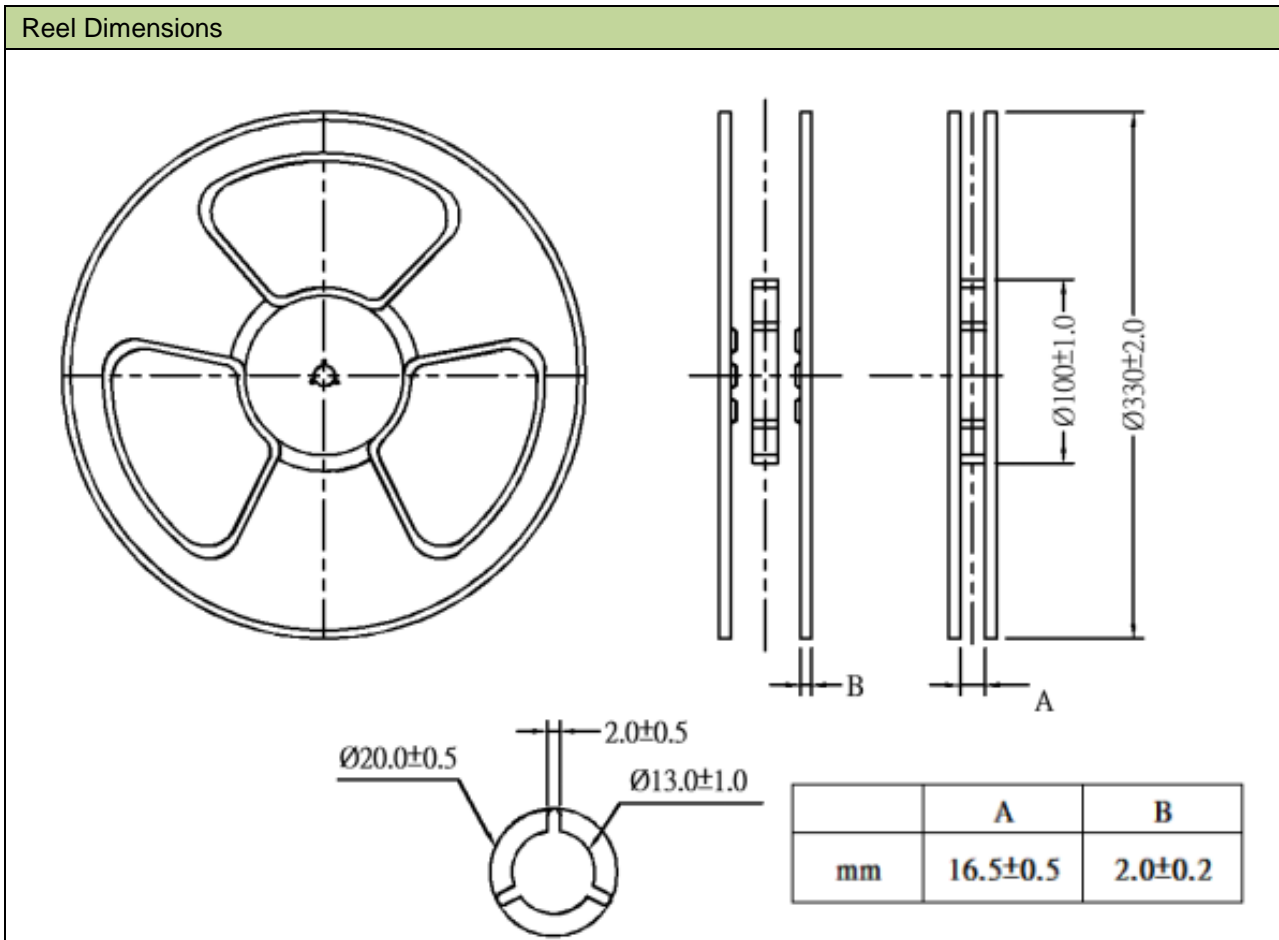

• Peel force of top cover tape

The peel speed shall be about 300mm/minute

The peel force of top cover tape shall be between 0.1 to 1.3 N

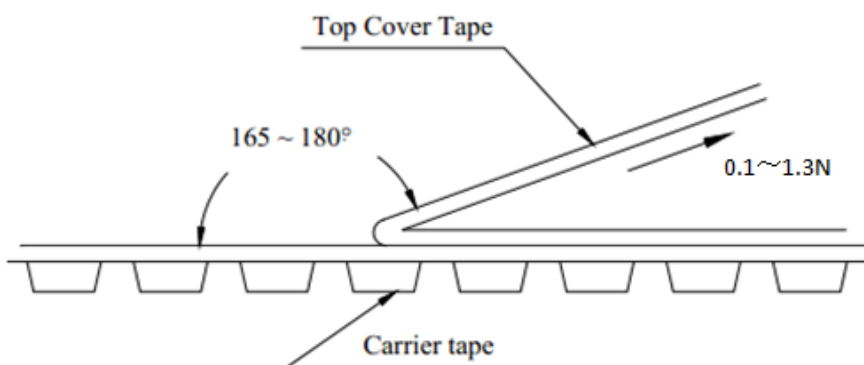

• Numbers of taping

500pieces/reel