



Descriptions

The NE5532DR is a dual operational amplifier IC designed for improved tone control and is well suited for audio applications. Its noise-free, high gain bandwidth, high output current, and low distortion ratio make it suitable not only for acoustic electronic components of audio preamplifiers and active filters, but also for industrial measurement tools. It is also suitable for headphone amplifiers with high output currents, and can be applied to general purpose portable integrated power amplifiers to appropriately bias input low voltage sources in low voltage single supply applications.

Feature

- Operating voltage($\pm 2V \sim \pm 18V$)
- Low input noise voltage (Typical value $0.8\mu V_{rms}$)
- Wide gain bandwidth product (Typical value 15MHz)
- Low distortion (Typical value 0.0005%)
- Rate of conversion (Typical value $5V/\mu s$)
- Bipolar technique

Applications

- Audio Preamplifiers
- Active Filters
- Headphone Amplifiers
- Industrial Measurement Equipment

Ordering Information

Product Model	Package Type	Packing	Packing Qty
NE5532DR	SOP-8(SOIC-8)	Tape	2500Pcs/Reel

Internal Block Diagram (1/2)

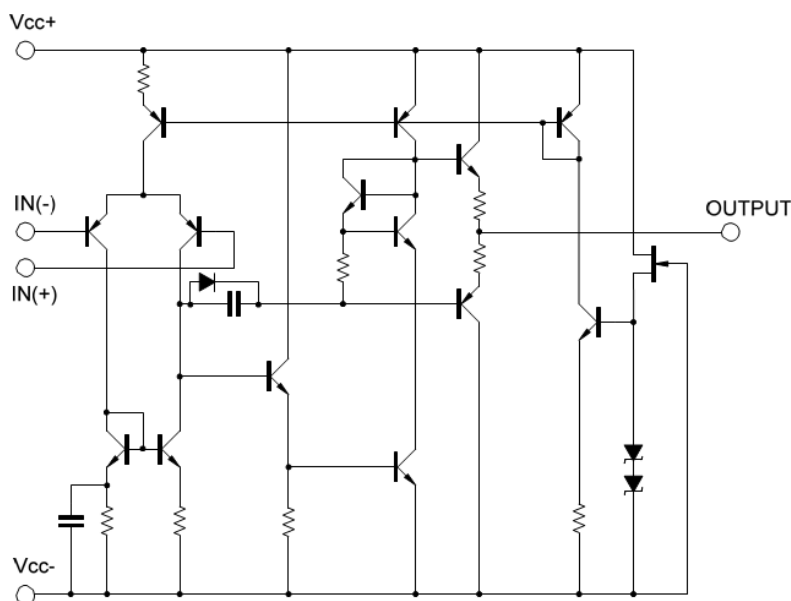



Pin Configurations

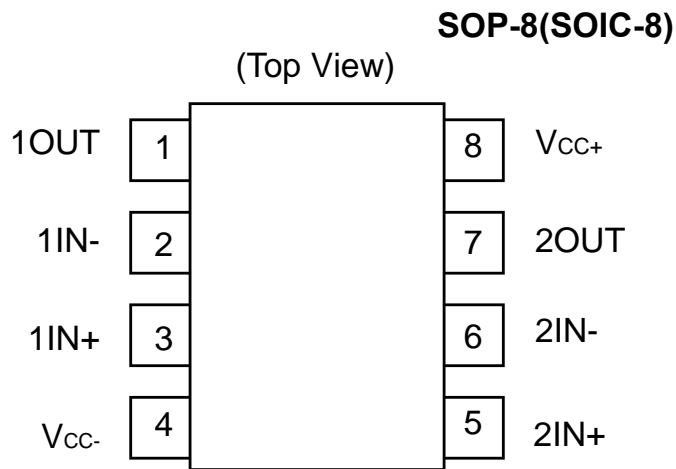

Pin Description

Pin	Symbol	I/O	Pin Description
1	1OUT	O	Output
2	1IN-	I	Inverting input
3	1IN+	I	Noninverting input
4	V _{CC-}	—	Negative supply
5	2IN+	I	Noninverting input
6	2IN-	I	Inverting input
7	2OUT	O	Output
8	V _{CC+}	—	Positive supply



Absolute Maximum Ratings

($T_A=25^\circ\text{C}$, not otherwise specified.)

Parameters	Symbol	Scope of scope	Unit of work
Supply voltage	V_{CC+}/V_{CC-}	± 18	V
Input voltage	V_{in}	± 15	V
Differential input voltage	$V_{I(DIFF)}$	± 30	V
Current of output	I_{OUT}	± 50	mA
Power consumption		440	mV
Temperature of junction	T_J	125	$^\circ\text{C}$
Operating temperature	T_{OPR}	-40 ~ +85	$^\circ\text{C}$
Temperature of storage	T_{STG}	-40 ~ +125	$^\circ\text{C}$

Note: Exceeding the limit parameters listed may lead to permanent damage inside the chip, and long-term operation under the limit conditions will affect the reliability of the chip.

DC Electrical Characteristics

($V_+ / V_- = \pm 15\text{V}$, $T_A = 25^\circ\text{C}$, Unless otherwise stated.)

Parameters	Symbol	Condition of test	Min	Typ	Max	Unit
Input bias voltage	$V_{I(OFF)}$	$R_S \leq 10\text{k}\Omega$		0.5	3	mV
Input bias voltage	$I_{I(OFF)}$			5	200	nA
Input bias current	$I_{I(BIAS)}$			100	500	nA
Large signal voltage gain	G_V	$V_{OUT} = \pm 10\text{V}$, $R_L \geq 2\text{k}\Omega$	90	110		dB
Output voltage swing	V_{OM}	$R_L \geq 2\text{k}\Omega$	± 12	± 13.5		V
Input the common mode voltage	$V_{I(CM)}$		± 12	± 13.5		V
Common mode inhibition ratio	CMRR	$R_S \leq 10\text{k}\Omega$	80	110		dB
Supply voltage rejection ratio	SVR	$R_S \leq 10\text{k}\Omega$	80	110		dB
Current of operation	I_{CC}			6	9	mA
Rate of conversion	SR	$R_L \geq 2\text{k}\Omega$		5		V/ μs
Gain bandwidth product	GB	$f = 10\text{KHz}$		15		MHz
Total harmonic distortion	THD	$G_V = 20\text{dB}$, $V_{OUT} = 5\text{V}$, $R_L = 2\text{k}\Omega$, $f = 1\text{KHz}$		0.0005		%
Input noise voltage	eN	R_{IAA} $R_S = 2.2\text{ k}\Omega$, 30kHz LPF		0.8		μVrms



Typical characteristics

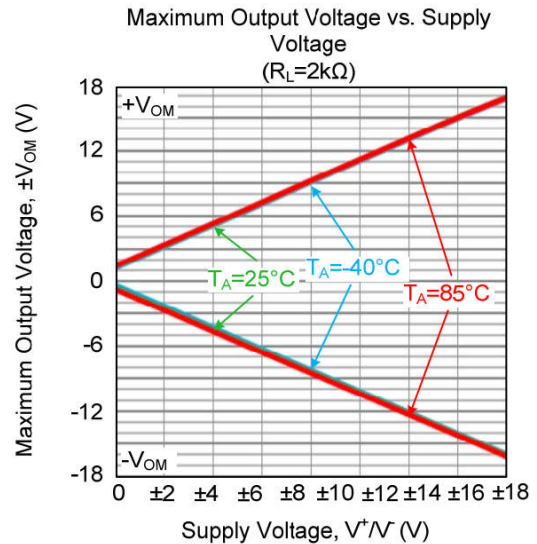
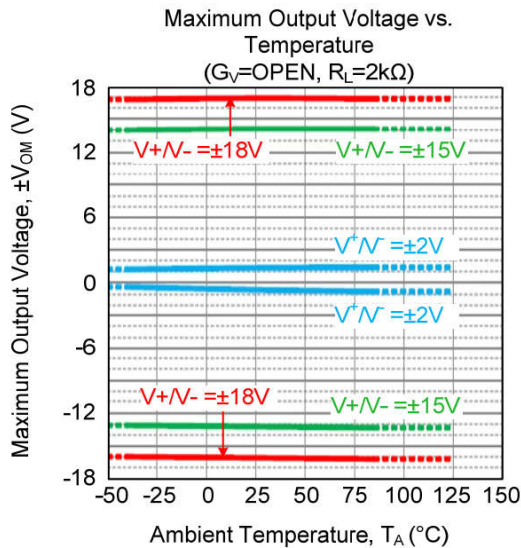
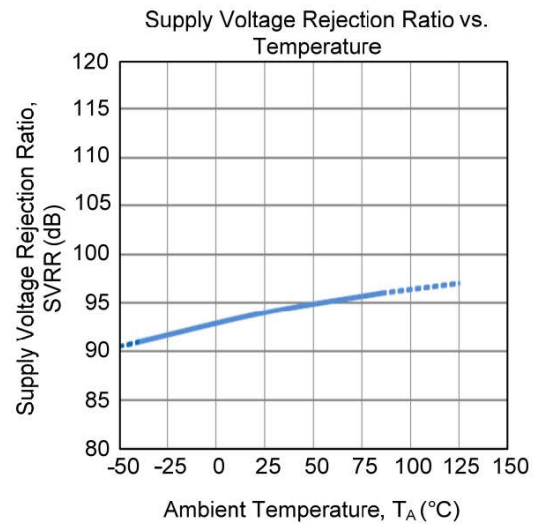
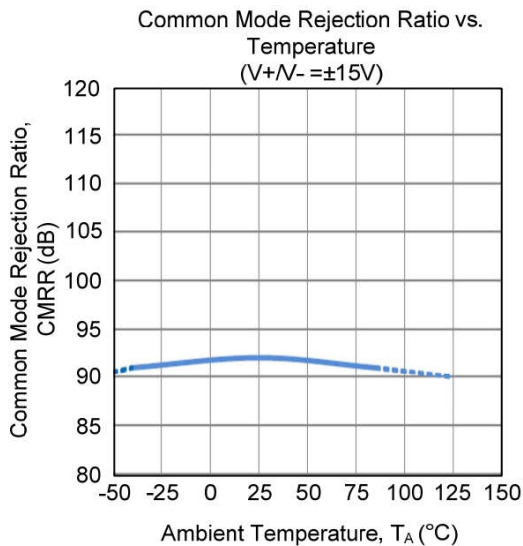
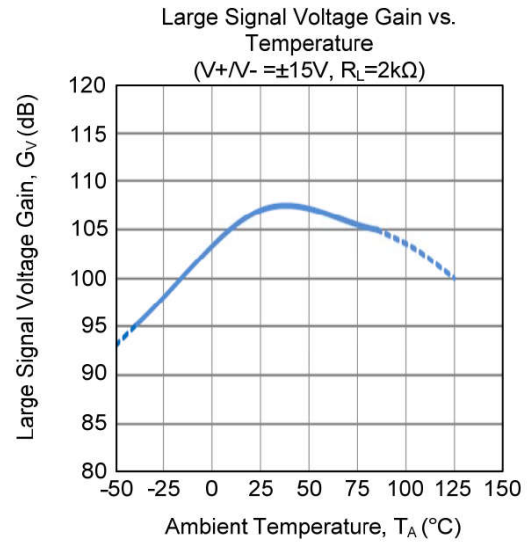
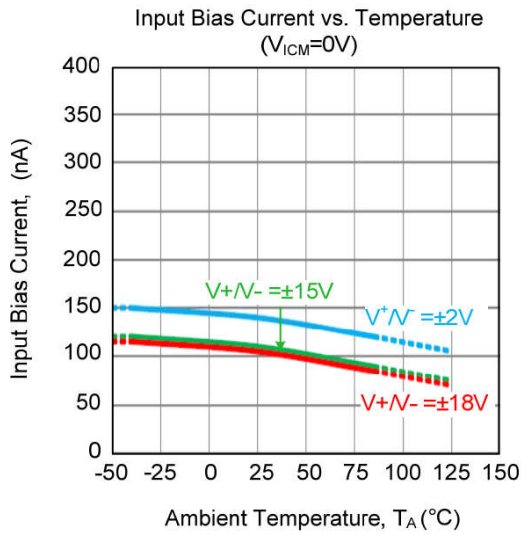

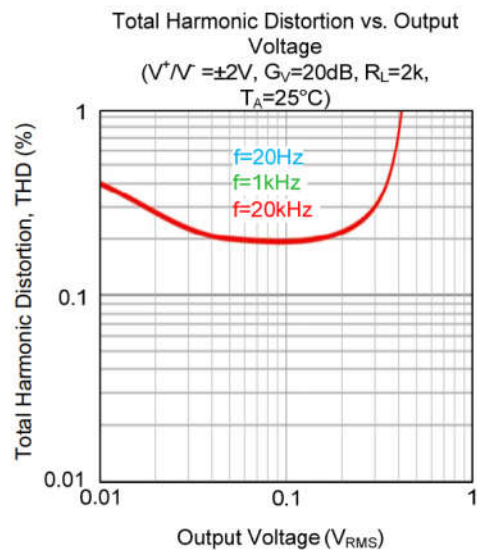
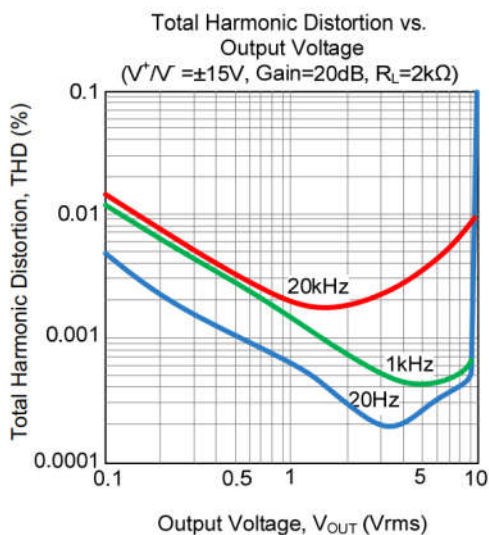
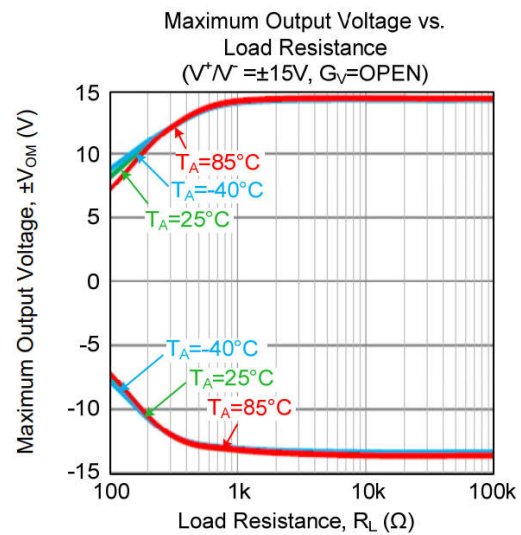
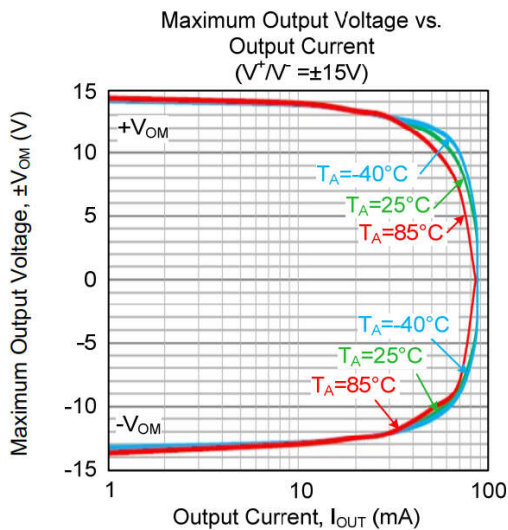
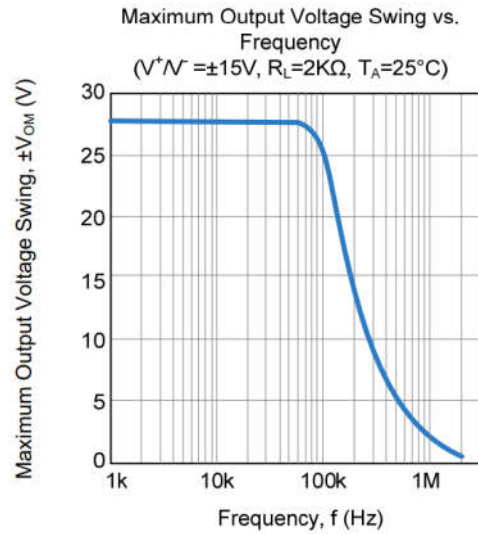
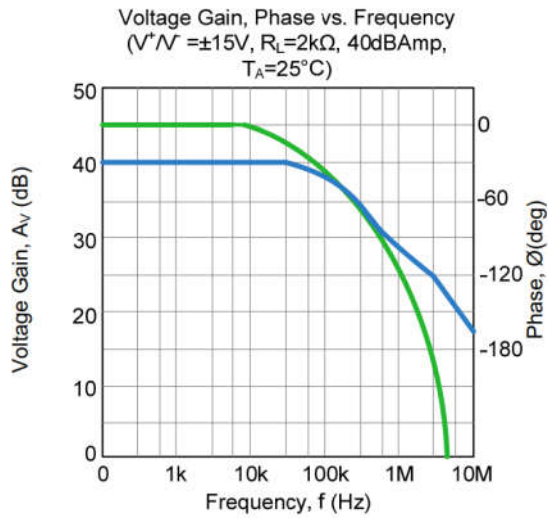

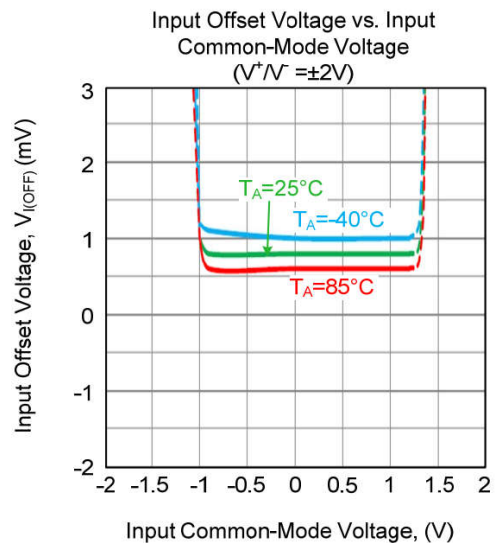
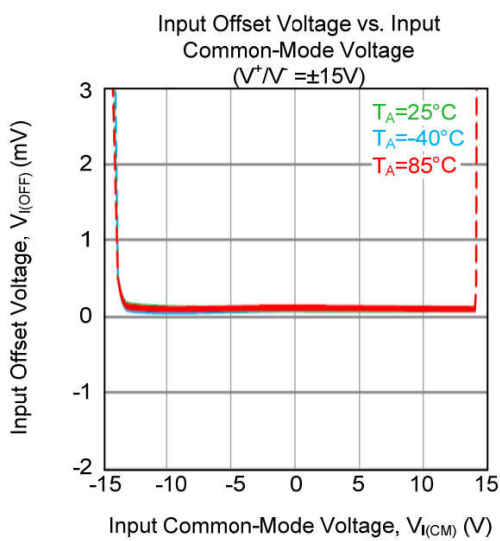
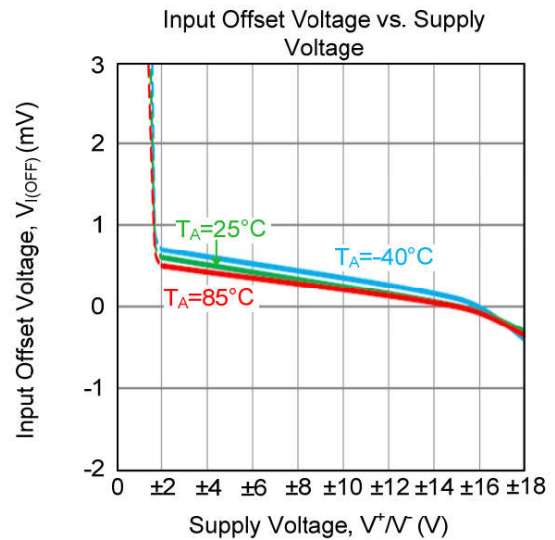
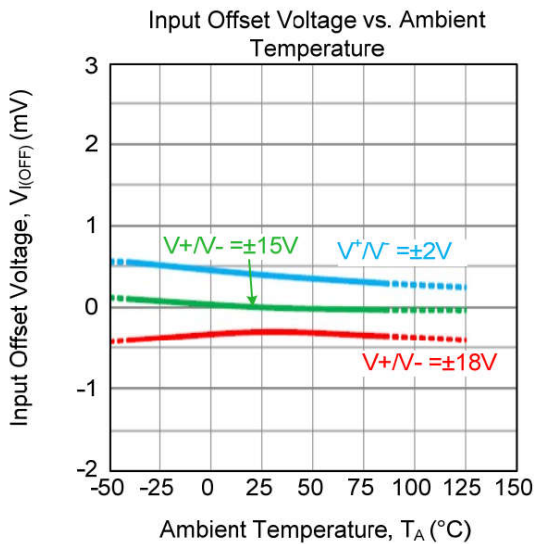
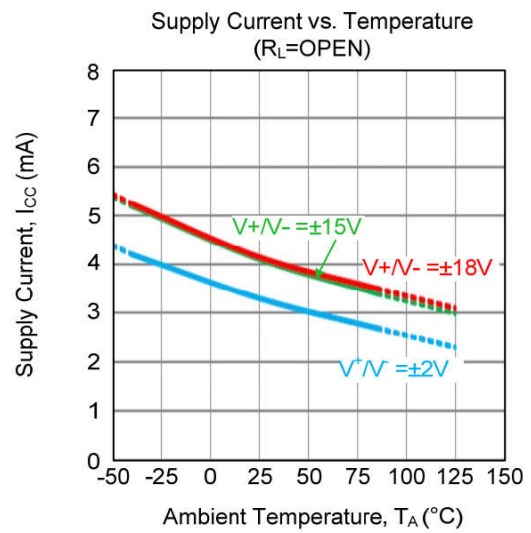
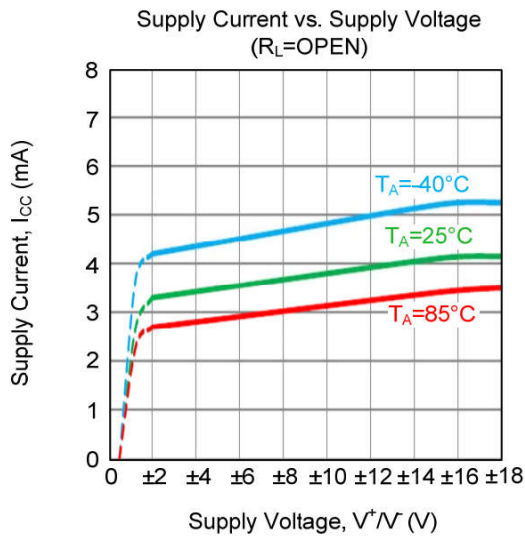

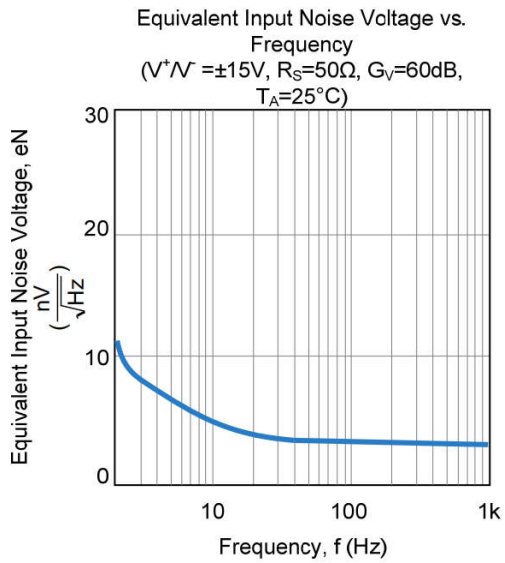
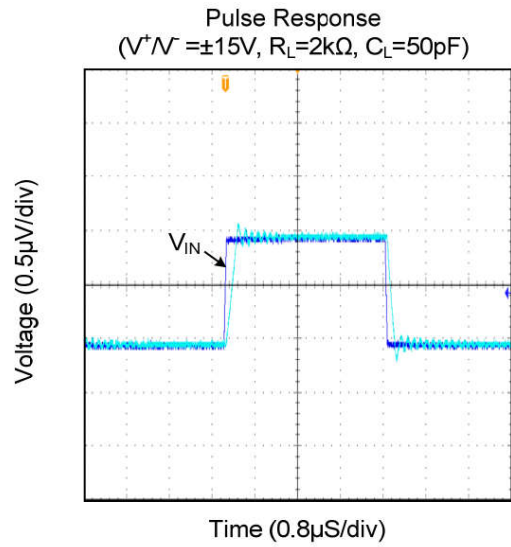
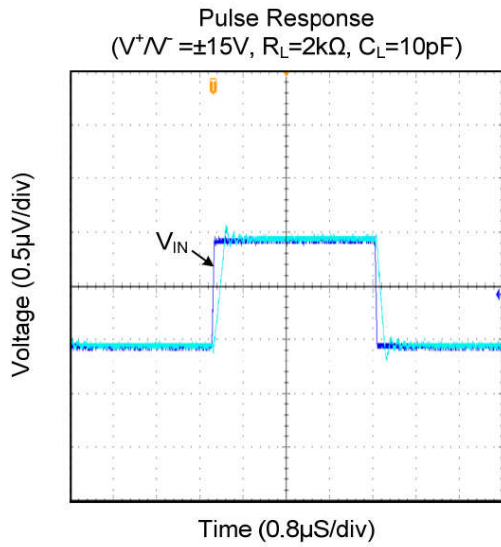



Package Information
SOP-8(SOIC-8)

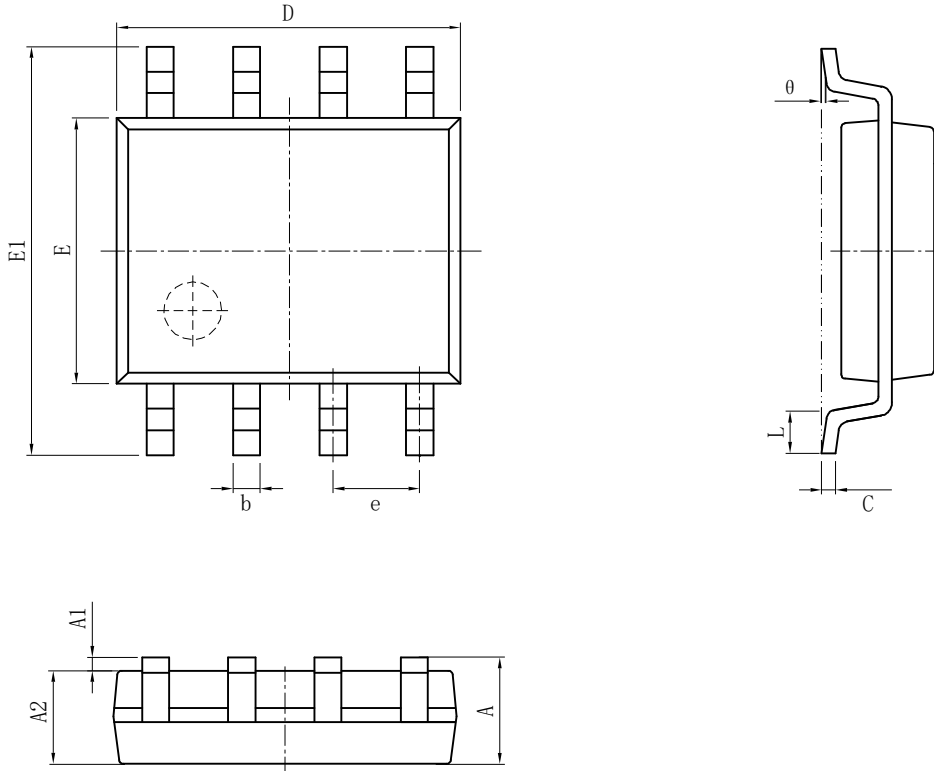

Symbol	Size	Dimensions In Millimeters		Symbol	Size	Dimensions In Inches	
		Min(mm)	Max(mm)			Min(in)	Max(in)
A		1.350	1.750	A		0.053	0.069
A1		0.100	0.250	A1		0.004	0.010
A2		1.350	1.550	A2		0.053	0.061
b		0.330	0.510	b		0.013	0.020
c		0.170	0.250	c		0.006	0.010
D		4.700	5.100	D		0.185	0.200
E		3.800	4.000	E		0.150	0.157
E1		5.800	6.200	E1		0.228	0.224
e		1.270(BSC)		e		0.050(BSC)	
L		0.400	1.270	L		0.016	0.050
θ		0°	8°	θ		0°	8°



Attention

- Any and all HUA XUAN YANG ELECTRONICS products described or contained herein do not have specifications that can handle applications that require extremely high levels of reliability, such as life-support systems, aircraft's control systems, or other applications whose failure can be reasonably expected to result in serious physical and/or material damage. Consult with your HUA XUAN YANG ELECTRONICS representative nearest you before using any HUA XUAN YANG ELECTRONICS products described or contained herein in such applications.
- HUA XUAN YANG ELECTRONICS assumes no responsibility for equipment failures that result from using products at values that exceed, even momentarily, rated values (such as maximum ratings, operating condition ranges, or other parameters) listed in products specifications of any and all HUA XUAN YANG ELECTRONICS products described or contained herein.
- Specifications of any and all HUA XUAN YANG ELECTRONICS products described or contained herein stipulate the performance, characteristics, and functions of the described products in the independent state, and are not guarantees of the performance, characteristics, and functions of the described products as mounted in the customer's products or equipment. To verify symptoms and states that cannot be evaluated in an independent device, the customer should always evaluate and test devices mounted in the customer's products or equipment.
- HUA XUAN YANG ELECTRONICS CO.,LTD. strives to supply high-quality high-reliability products. However, any and all semiconductor products fail with some probability. It is possible that these probabilistic failures could give rise to accidents or events that could endanger human lives, that could give rise to smoke or fire, or that could cause damage to other property. When designing equipment, adopt safety measures so that these kinds of accidents or events cannot occur. Such measures include but are not limited to protective circuits and error prevention circuits for safe design, redundant design, and structural design.
- In the event that any or all HUA XUAN YANG ELECTRONICS products(including technical data, services) described or contained herein are controlled under any of applicable local export control laws and regulations, such products must not be exported without obtaining the export license from the authorities concerned in accordance with the above law.
- No part of this publication may be reproduced or transmitted in any form or by any means, electronic or mechanical, including photocopying and recording, or any information storage or retrieval system, or otherwise, without the prior written permission of HUA XUAN YANG ELECTRONICS CO.,LTD.
- Information (including circuit diagrams and circuit parameters) herein is for example only ; it is not guaranteed for volume production. HUA XUAN YANG ELECTRONICS believes information herein is accurate and reliable, but no guarantees are made or implied regarding its use or any infringements of intellectual property rights or other rights of third parties.
- Any and all information described or contained herein are subject to change without notice due to product/technology improvement, etc. When designing equipment, refer to the "Delivery Specification" for the HUA XUAN YANG ELECTRONICS product that you intend to use.