

**Single channel 2-input
XOR gate**

SN74LVC1G86

Product Data Sheet

**AOTE DCC
RELEASE**

◆ Summary :

SN74LVC1G86 is a single channel 2-input XOR gate that can operate within a supply voltage range of 1.65V to 5.5V.

The SN74LVC1G86 device executes the Boolean function $Y = \overline{A}B + A\overline{B}$ in positive logic, and can be used for loff local power-off applications. When the device is powered off, the loff circuit will disable the output to prevent backflow current from damaging the device.

The device is packaged in SOT23-5 and SC70-5. The working temperature range is from $-40^{\circ}\text{C} \sim +125^{\circ}\text{C}$

◆ Product features

- Small Package: SOT23-5、 SC70-5
- Working voltage range: 2.0V~5.5V
- Low power consumption: 0.1μA (typical value)
- Working temperature range: $-40^{\circ}\text{C} \sim +125^{\circ}\text{C}$
- Input voltage up to 5.5V
- High Output driver: When powered by 3.0V, output driver $\pm 24\text{mA}$

◆ Applications

- Communication receiver
- Blu ray player and home theater
- digital photo frame (DPF)
- High speed data acquisition and generation
- Personal Navigation Device (GPS)
- Portable media player

◆ Packaging and Order Description

Product Name	Order Model	Temperature Range (°C)	boxed type	screen printing	MSL(3)	Packing Specification
SN74LVC1G86	SN74LVC1G86DCKR	$-40^{\circ}\text{C} \sim +125^{\circ}\text{C}$	SC70-5	CH5	MSL3	Tape and Reel, 3000
	SN74LVC1G86DBVR	$-40^{\circ}\text{C} \sim +125^{\circ}\text{C}$	SOT23-5	C86J	MSL3	Tape and Reel, 3000

Attention:

(1) This information is the latest data for the current version. If these data are updated, they will be promptly updated on our official website without further notice.

(2) Silk screen printing may have additional codes for internal control traceability of products (including data codes and supplier codes) or marking the place of origin.

(3) MSL, Humidity sensitivity level classified according to JEDEC industry standards.

(4) equivalent SOT353

◆ **Logic diagram**



◆ **Menu**

Input		Output
A	B	Y
H	H	L
L	H	H
H	L	H
L	L	L

H=high level L=Low level

◆ **IEE/IEC Logic diagram**

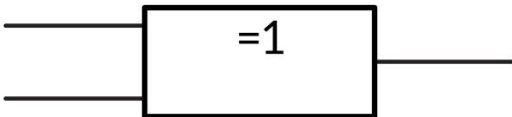

◆ **On-product information:**

• **Footage image**

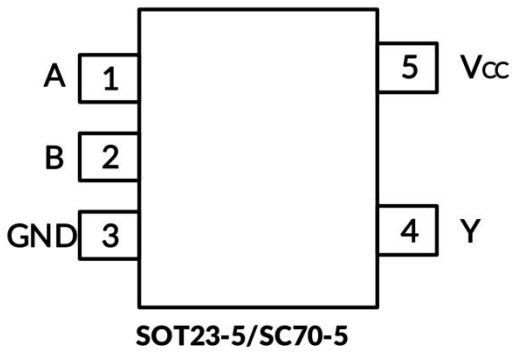

Pin	Pin Name	I/O	Function Description
1	A	I	A input
2	B	I	B input
3	GND	P	grounding
4	Y	O	Y output
5	Vcc	P	power supply

◆ **Absolute maximum rating** Within the natural ventilation temperature range (unless otherwise specified)

	Parameter	Min	Max	Unit	
VCC	Power supply voltage range	-0.5	6.5	V	
VI	Input voltage range	-0.5	6.5	V	
Vo	The voltage range applicable to any output under high impedance or power-off conditions	-0.5	6.5	V	
Vo	The voltage range applicable to any output in either high or low level state	-0.5	VCC+0.5	V	
I _{IK}	Input clamp current V _I < 0	-	-50	mA	
I _{OK}	Output clamp current V _O < 0	-	-50	mA	
I _O	Continuous output current	-	± 50	mA	
	Continuous current through VCC or GND	-	± 100	mA	
• current parameters					
θ _{JA}	Thermal resistance to the environment	SOT23-5	-	230	°C/W
		SC70-5	-	380	
• current parameters					
temperature parameter	Junction temperature, T _J	-65	150	°C	
	Storage temperature range, T _{stg}	-65	150		

◆ **ESD level**

The following ESD information is only applicable to sensitive equipment operated within an ti-static protection zones

	nominal value	Unit	 ESD sensitivity warning The scope of ESD damage can range from minor performance degradation to complete equipment failure. Precision integrated circuits may be more susceptible to damage as very small parameter changes can result in devices not meeting their published parameter specifications.
human model (HBM)	±8000	V	
Mechanical Model (MM)	±500		

Attention:

- (1) This only represents the limit values obtained by the product under testing conditions, and does not mean that the product can work normally under these conditions or other parameter conditions beyond the specifications. Exceeding the range specified by the absolute maximum rated value above will cause damage to the product, and it is impossible to predict the working state of the product outside of the above conditions. If the product operates under conditions other than those mentioned above for a long time, it may affect its performance.
- (2) If the input and output current ratings are followed, it may exceed the input and output negative voltage ratings.
- (3) The value of VCC is provided in the recommended working condition table.
- (4) The thermal impedance of the package is calculated according to JEDEC-51 standard:
- (5) The maximum power consumption is a function of T_{J (MAX)}, RθJA, and T_A. The maximum power consumption at any ambient temperature is Po=(T_{J (MAX)} - T_A)/RθJA, which is suitable for packaging directly soldered to PCB.

(

◆ Electrical Characteristics

(Within the natural ventilation temperature range (typical test conditions are: TA=+25 ° C, full temperature=-40 ° C~125 ° C))

◆ Recommended working conditions

Parameter	symbol	Test conditions	Min	Max	Unit
power supply voltage	V _{CC}	work	1.65	5.5	V
		Only retain data	1.5	5.5	
High level input voltage	V _{IH}	V _{CC} = 1.65V - 1.95V	0.65 x V _{CC}	-	V
		V _{CC} =2.3V - 2.7V	1.7		
		V _{CC} =3V - 3.6V	2.2		
		V _{CC} =4.5V - 5.5V	0.7 x V _{CC}		
Low level input voltage	V _{IL}	V _{CC} = 1.65V - 1.95V	-	0.2 x V _{CC}	V
		V _{CC} =2.3V - 2.7V		0.3	
		V _{CC} =3V - 3.6V		0.4	
		V _{CC} =4.5V - 5.5V		0.15 x V _{CC}	
input voltage	V _I	-	0	5.5	V
output voltage	V _O	-	0	V _{CC}	V
Input conversion up or down rate	t _r , t _f	V _{CC} = 1.8±0.15V, 2.5V±0.2V	-	20	ns/V
		V _{CC} =3.3V ±0.3V		10	
		V _{CC} =5V ±0.5V		5	
Working temperature range under natural ventilation conditions	T _A	-	-40	125	°C

 All unused input ports of the device must be kept at V_{CC} or GND to ensure proper operation of the device

◆ DC characteristics

Parameter	Test conditions	Vcc	temperature	Min	Typ	Max	Unit
V _{OH}	I _{OH} = -100μA	1.65V-5.5V	Full temperature	V _{CC} -0.1	-	-	V
	I _{OH} = -4mA	1.65V		1.2			
	I _{OH} = -8mA	2.3V		1.9			
	I _{OH} = -16mA	3V		2.4			
	I _{OH} = -24mA			2.3			
	I _{OH} = -32mA	4.5V		3.8			
V _{OL}	I _{OH} = 100μA	1.65V-5.5V	Full temperature	-	-	0.1	V
	I _{OH} = 4mA	1.65V		-		0.45	
	I _{OH} = 8mA	2.3V		-		0.3	
	I _{OH} = 16mA	3V		-		0.4	
	I _{OH} = 24mA			-		0.55	
	I _{OH} = 32mA	4.5V		-		0.55	
I _I Input A or B	V _I = 5.5V or GND	0V - 5.5V	+25°C Full temperature	-	± 0.1	± 5	μA
I _{off}	V _I or V _O = 5.5V	0V	+25°C Full temperature	-	± 0.1	± 10	μA
I _{CC}	V _I = 5.5V or GND, I _O = 0	1.65V - 5.5V	+25°C Full temperature	-	0.1	10	μA
ΔI _{CC}	One input at V _{CC} -0.6V, Other inputs at V _{CC} or GND	3V - 5.5V	Full temperature			500	μA

(1) All unused input ports of the device must be kept at VCC or GND to ensure proper operation of the device.

(2) The limit value is 100% production testing conducted at 25°C. Ensure the limitation of the working temperature range by utilizing the correlation of statistical quality control (SQC) methods.

(3) Typical values represent the most likely parameter specifications determined during characterization. The actual typical values may vary over time and will also depend on the application and configuration.

◆ AC characteristics

Parameter	symbol	Test conditions		°C	Min	Typ	Max
propagation delay	t _{pd}	V _{CC} = 1.8V ± 0.15V	C _L = 30 pF, R _L = 1 kΩ	-	14.2	-	ns
		V _{CC} = 2.5V ± 0.2V	C _L = 30 pF, R _L = 500Ω		11.1		
		V _{CC} = 3.3V ± 0.3V	C _L = 50 pF, R _L = 500Ω		6.7		
		V _{CC} = 5V ± 0.5V	C _L = 50 pF, R _L = 500Ω		5.3		
Input capacitance	C _i	V _{CC} = 3.3V	V _I = V _{CC} or GND		4		pF
Powerconsumption capacitor	C _{pd}	V _{CC} = 1.8V	f = 10MHz	-	20	-	pF
		V _{CC} = 2.5V			21		
		V _{CC} = 3.3V			22		
		V _{CC} = 5V			25		

(1) All unused input ports of the device must be kept at VCC or GND to ensure proper operation of the device.

(2) This parameter is ensured by design and/or characteristics and has not been tested in production.

(3) Typical values represent the most likely parameter specifications determined during characterization. The actual typical values may vary over time and will also depend on the application and configuration.

◆ **Parameter measurement information**
open-drain output

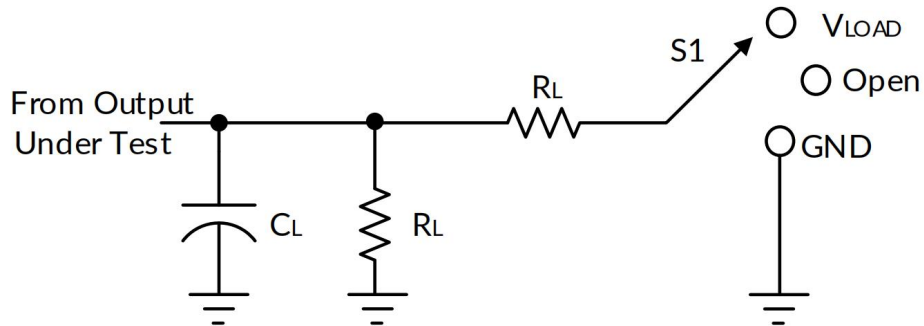

TEST	S1
t _{PLH} /t _{PHL}	Open
t _{PLZ} /t _{PZL}	V _{LOAD}
t _{PHZ} /t _{PZH}	GND

V _{CC}	INPUTS		V _M	V _{LOAD}	C _L	R _L	V _Δ
	V _I	t _r /t _f					
1.8V±0.15V	V _{CC}	≤2ns	V _{CC} /2	2 x V _{CC}	30pF	1KΩ	0.15V
2.5V±0.2V	V _{CC}	≤2ns	V _{CC} /2	2 x V _{CC}	30pF	500Ω	0.15V
3.3V±0.3V	3V	≤2.5ns	1.5V	6V	50pF	500Ω	0.3V
5V±0.5V	V _{CC}	≤2.5ns	V _{CC} /2	2 x V _{CC}	50pF	500Ω	0.3V

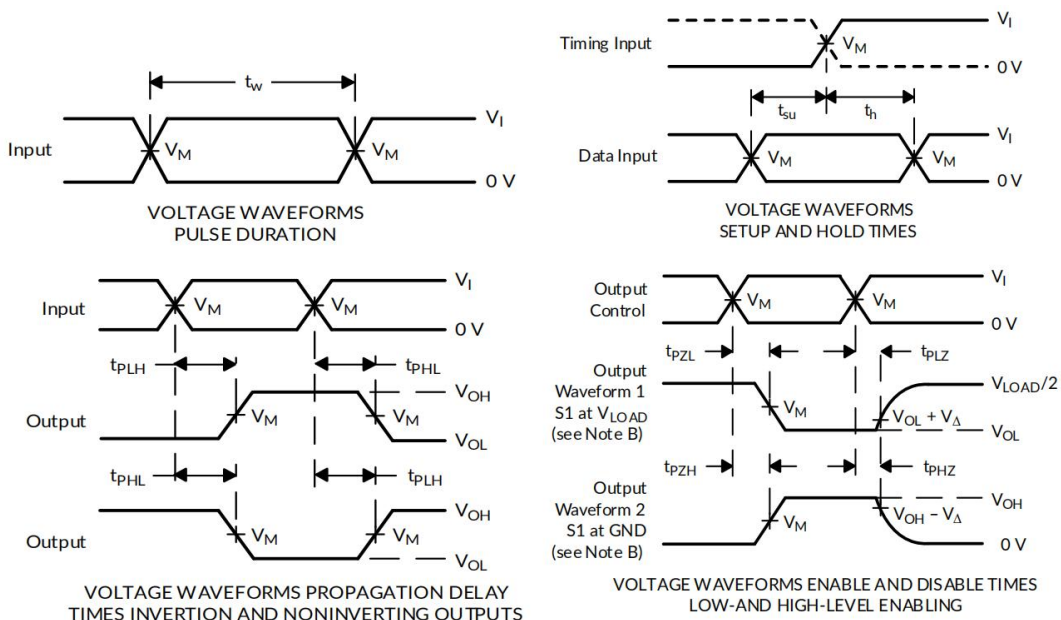

- Note: A.CL includes probe and fixture capacitors.
 B. Waveform 1 is used for outputs with internal conditions, where the output is low unless disabled by the output controller. Waveform 2 is used for outputs with internal conditions, where the output is high unless disabled by the output controller.
 C. All input pulses are provided by a generator with the following characteristics: PRR≤10MHz, Zo=50Ω
 D. Output one measurement at a time, with a transition for each measurement.
 E. T_{PLZ} and t_{PHZ} are the same as t_{dis}.
 F. T_{PZL} and t_{PZH} are the same as t_{en}.
 G. T_{PLH} and t_{PHL} are the same as t_{pd}.
 H. Not all parameters and waveforms are applicable to all devices.

◆ Packaging specifications size

REEL DIMENSIONS

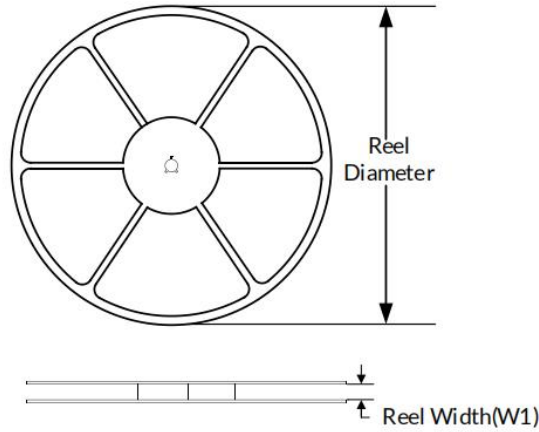

TAPE DIMENSION

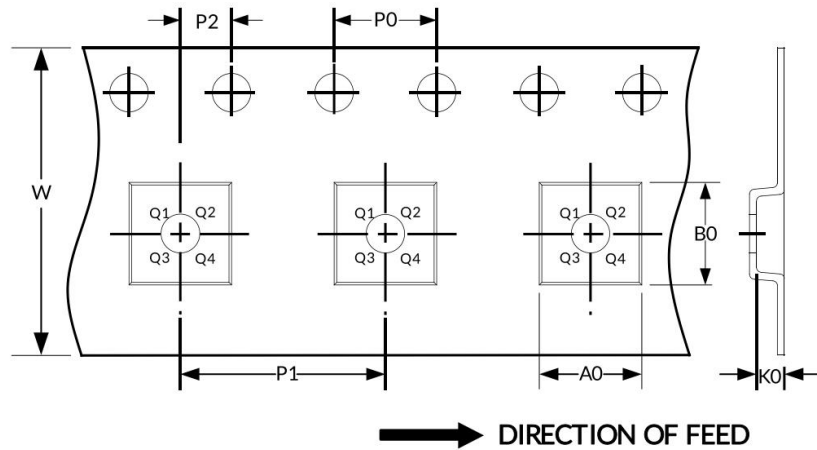

Attention: The pictures are for reference only. Please use the physical object as the standard

◆ Key parameter table

Package Type	Reel Diameter	Reel Width (mm)	A0 (mm)	B0 (mm)	K0 (mm)	P0 (mm)	P1 (mm)	P2 (mm)	W (mm)	Pin1 Quadrant
SC70-5	7"	9.5	2.25	2.55	1.20	4.0	4.0	2.0	8.0	Q3
SOT23-5	7"	9.5	3.20	3.20	1.40	4.0	4.0	2.0	8.0	Q3

Attention:

All dimensions are nominal sizes.

Excluding plastic wrap or metal protrusions with a maximum of 0.15 millimeters on each side.

◆ **Packaging specifications and dimensions**

Attention:

- 1、Excluding plastic wrap or metal protrusions with a maximum of 0.15mm on each side.
- 2、BSC (Basic Center Spacing), where the "basic" spacing is the nominal spacing.
- 3、This image is subject to change without prior notice

SOT23-5

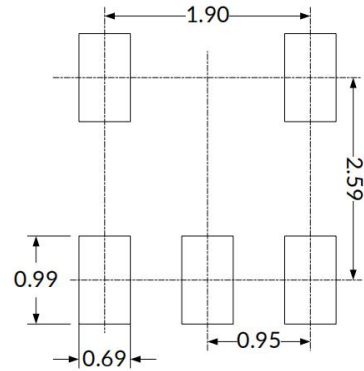
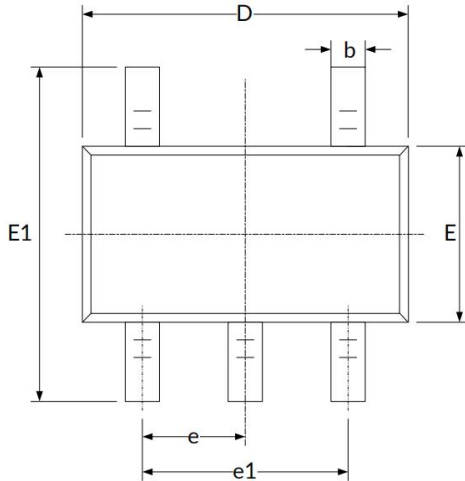

RECOMMENDED LAND PATTERN (Unit: mm)

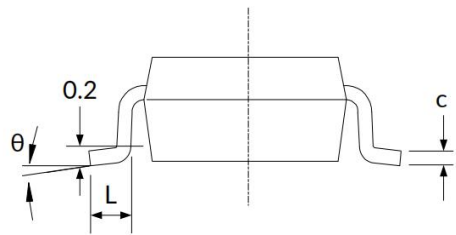
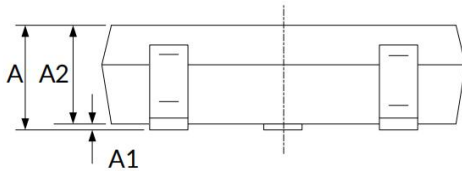

symbol	Dimensions (in millimeters)		Dimensions (in inches)	
	Min	Max	Min	Max
A	1.050	1.250	0.041	0.049
A1	0.000	0.100	0.000	0.004
A2	1.050	1.150	0.041	0.045
b	0.300	0.500	0.012	0.020
C	0.100	0.200	0.004	0.008
D	2.820	3.020	0.111	0.119
E	1.500	1.700	0.059	0.067
E1	2.650	2.950	0.104	0.116
e	0.950 (BSC)		0.037 (BSC)	
e1	1.800	2.000	0.071	0.079
L	0.300	0.600	0.012	0.024
θ	0°	8°	0°	8°

◆ Packaging specifications and dimensions

Attention:

- 1、 Excluding plastic wrap or metal protrusions with a maximum of 0.15mm on each side.
- 2、 BSC (Basic Center Spacing), where the "basic" spacing is the nominal spacing.
- 3、 This image is subject to change without prior notice

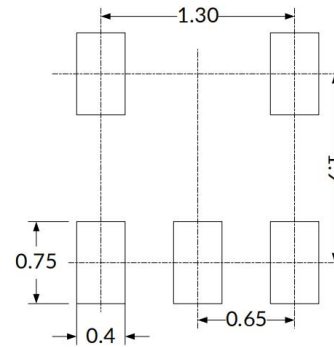
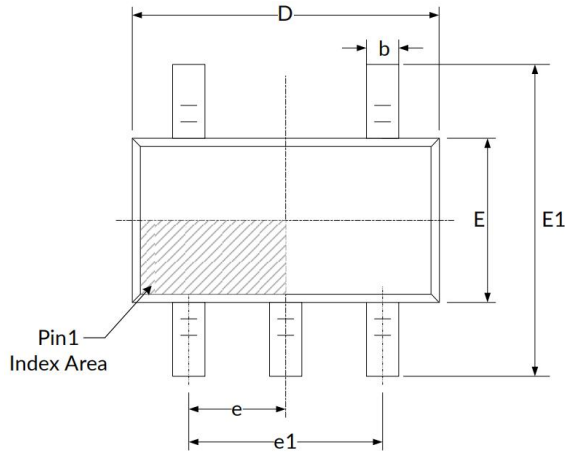
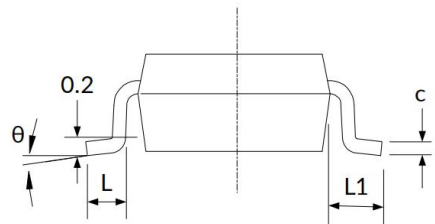
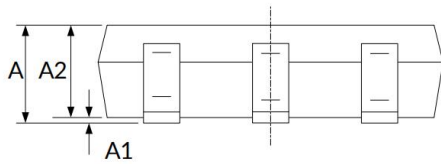
SC70-5

RECOMMENDED LAND PATTERN (Unit: mm)

symbol	Dimensions (in millimeters)		Dimensions (in inches)	
	Min	Max	Min	Max
A	0.900	1.100	0.035	0.043
A1	0.000	0.100	0.000	0.004
A2	0.900	1.000	0.035	0.039
b	0.150	0.350	0.006	0.014
c	0.080	0.150	0.003	0.006
D	2.000	2.200	0.079	0.087
E	1.150	1.350	0.045	0.053
E1	2.150	2.450	0.085	0.096
e	0.650 (TYP)		0.026(TYP)	
e1	1.200	1.400	0.047	0.055
L	0.260	0.460	0.010	0.018
L1	0.525(REF)		0.021(REF)	
θ	0°	8°	0°	8°

◆ Attention

- AOTE implements dynamic technical updates. Specifications are subject to change. Refer to the official website for the latest version.
- Users must strictly adhere to specified conditions. Failures caused by misuse (overload, high temperature, incompatible circuits) are excluded from warranty.
- Contact technical support for customized validation in critical applications (medical devices, industrial control).
- This document is valid until December 31, 2026 Updates will be notified on the official website.
- For further clarification on technical specifications or application solutions, please contact us through official channels: